

STEERING

CONTENTS OF THIS SECTION

SUBJECT	PAGE	SUBJECT	PAGE
Standard Steering Gear		Steering Gear - Remove	9A-7
General Description	9-1	Steering Gear - Disassemble	9A-7
Periodic Service	9-2	Cleaning and Inspection	9A-12
Adjustments on Car	9-2	Sub-Assemblies - Assemble	9A-14
Minor Repairs	9-4	Steering Gear - Assemble	9A-17
Steering Column - Overhaul	9-5	Steering Gear - Install	9A-20
Steering Gear - Remove	9-16	Trouble Diagnosis	9A-20
Steering Gear - Disassemble	9-16	Specifications	9A-25
Cleaning and Inspection	9-17	Power Steering Pump	
Steering Gear - Assemble	9-18	General Description	9A-26
Steering Gear - Install	9-20	Operation	9A-28
Trouble Diagnosis and Testing	9-21	Filling Pump and Gear	9A-28
Specifications	9-23	Oil Flow - Low Speed or	
Special Tools	9-24	Partial Turn	9A-31
Power Steering Gear		Oil Flow - High Speed, No Turn,	
General Description	9A-1	Straight Ahead	9A-31
Design	9A-1	Oil Flow - Turn Against Resistance	9A-31
Operation	9A-2	Periodic Service Recommendations	9A-31
Operation Pressures	9A-2	Adjustments on Car	9A-33
Oil Flow - Straight Ahead Position	9A-2	Pump Belt Tension Adjustment	9A-33
Oil Flow - Right Turn Position	9A-3	Pump - Remove from Car	9A-33
Oil Flow - Left Turn Position	9A-5	Power Steering Pump - Disassemble	9A-33
Periodic Service Recommendations	9A-6	Cleaning and Inspection	9A-34
Adjustments on Car	9A-6	Steering Pump - Assemble	9A-34
Check Steering Gear Adjustment	9A-6	Steering Pump - Install	9A-37
Minor Repairs	9A-7	Trouble Diagnosis	9A-37
Removal of Pitman Shaft Seal with		Specifications	9A-41
Gear in Car	9A-7	Special Tools	9A-42

STANDARD STEERING GEAR

GENERAL DESCRIPTION

The standard steering gear (Fig. 9-1) is of the recirculating ball nut type having a gear ratio of 24 to 1 with an over-all ratio of 28.32 to 1. The steering shaft, worm shaft and worm nut are all in line, making a compact and easily serviced gear.

The steering shaft and worm shaft are separated with a flexible coupling which permits removal of the gear assembly or steering shaft (and column) independent of each other.

The mechanical element of this steering gear is a low-friction, high-efficiency recirculating ball system in which steel balls act as a rolling thread between the steering worm and nut. The nut is one

piece and is geared to the sector of the pitman shaft. Lash between the pitman shaft and rack piston nut is maintained by an adjusting screw which is retained in the end of the pitman shaft gear (Fig. 9-2).

The ball nut, mounted on the worm, is driven through steel balls which circulate in helical grooves in both the worm and nut. Ball return guides, attached to the nut, serve to recirculate the two sets of twenty-five balls each in the grooves.

As the steering wheel is turned to the right, the nut moves upward. When the wheel is turned to the left the nut moves downward.

The teeth on the sector, which are forged as part of the pitman shaft, and the ball nut are so designed

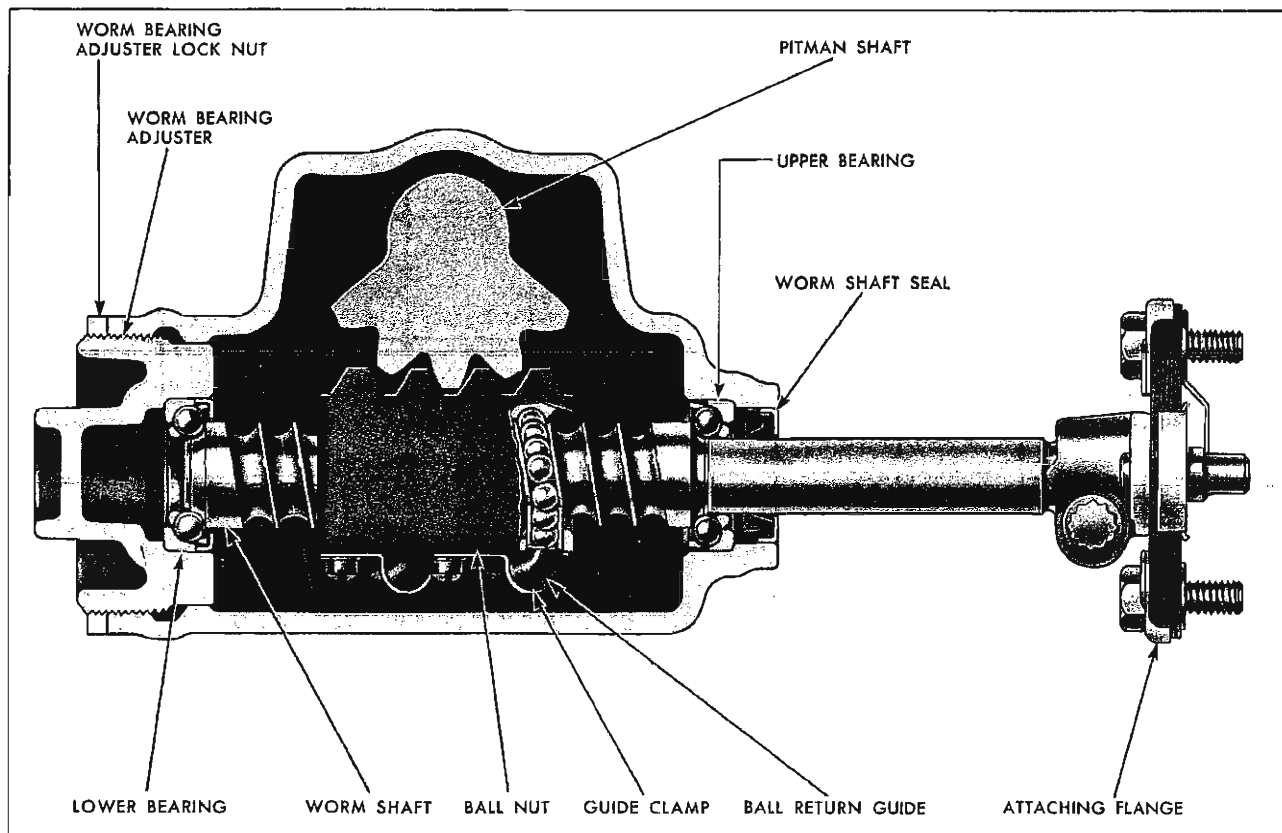

Fig. 9-1 Cross Section of Standard Steering Gear

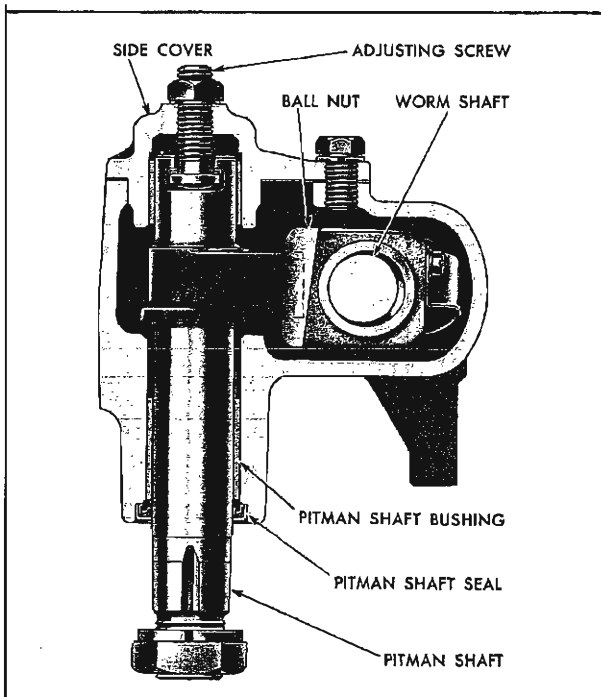

Fig. 9-2 Cross Section Through Pitman Shaft

that a tighter fit exists between the two when the front wheels are straight ahead. Proper engagement between the sector and the ball nut is obtained by an adjusting screw which moves the pitman shaft endwise, permitting desired engagement of the tapered teeth of the ball nut and sector gear. The worm bearing adjuster can be turned to provide proper preloading of the upper and lower bearings.

PERIODIC SERVICE

Periodic service consists of periodical lubrication as outlined in GENERAL LUBRICATION Section. The addition of the lubricant is to be made by removing the center side cover bolt (Fig. 9-3).

ADJUSTMENTS ON CAR

Correct adjustment of the steering gear is extremely important. Before any adjustments are made to the steering gear in an attempt to correct such conditions as shimmy, hard or loose steering and road shocks, careful check should be made to determine that front end alignment, shock absorbers,

wheel balance and tire pressure are correctly adjusted and/or operating satisfactorily.

There are two adjustments on the recirculating ball type steering gear:

1. Worm bearing preload adjustment.
2. Sector and ball nut and backlash adjustment.

CAUTION: It is very important when adjusting the steering gear that the adjustments be made in the above sequence. Failure to do so will result in damage to the steering gear.

ADJUST WORM BEARING PRELOAD

1. Disconnect steering connecting rod from pitman arm (Fig. 9-4).

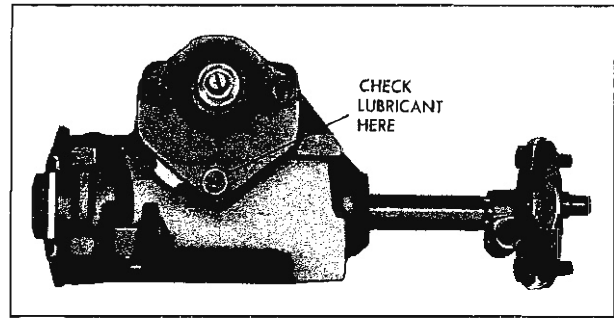

Fig. 9-3 Addition of Lubricant

2. Loosen pitman shaft adjusting screw lock nut and back off adjusting screw a few turns (Fig. 9-5).

3. Remove horn button or horn ring and steering wheel.

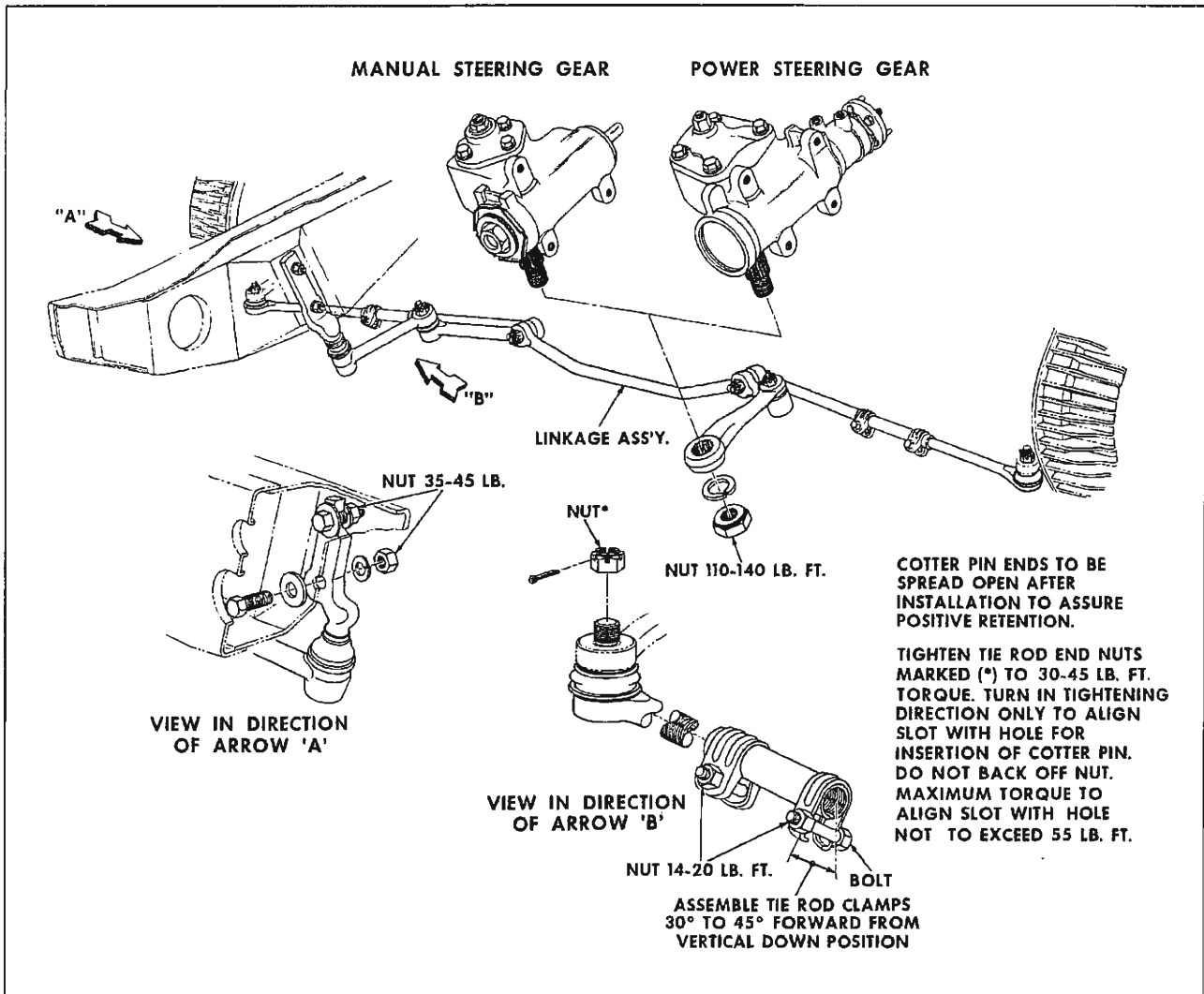

Fig. 9-4 Steering Linkage

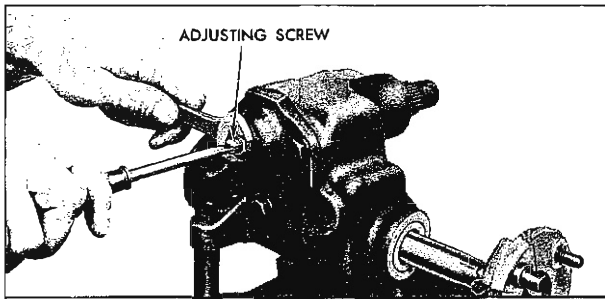

Fig. 9-5 Adjusting Pitman and Ball Nut Backlash

4. With lb. in. torque wrench attached to a 5/8"-12 point socket, measure and record at least 30° off center (Fig. 9-6).

NOTE: Do not use a torque wrench having maximum torque reading of more than 100 pounds inch. When taking following torque readings, take a reading, pulling the torque wrench to the right and a reading, pulling the torque wrench to the left. Total both readings and take one-half of this total as the average torque.

5. Torque required should be between 5-9 lb. in. To correct, loosen worm bearing adjuster lock nut with brass drift and turn adjuster to bring torque within limits.

6. Retighten lock nut when adjustment is correct and recheck as in Step 4 above.

ADJUST SECTOR AND BALL NUT BACKLASH

1. When worm bearing preload has been adjusted correctly, pitman shaft adjusting screw should be turned clockwise until a pull equal to the worm bearing preload plus 4-9 lb. in. is required to turn the wheel through the center.

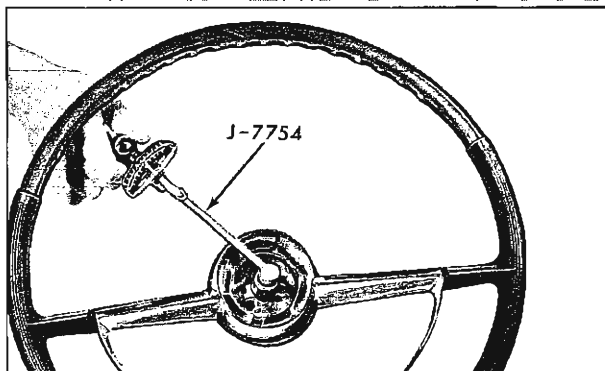

Fig. 9-6 Checking Steering Gear Adjustment

Total thrust bearing adjustment, pitman shaft adjustment, and drag to exceed 14 lb. in.

2. Tighten pitman shaft adjusting screw lock nut, and recheck adjustment.

3. Reassemble steering connecting rod to pitman arm. Set spokes of steering wheel in straight ahead position (mark on steering shaft up, Fig. 9-6). If road wheels are not straight ahead, adjust steering tie rods.

MINOR REPAIRS STANDARD AND DELUXE STEERING WHEEL

REMOVE AND REPLACE (Fig. 9-8)

1. Lift to remove ornament.
2. Remove nut and washer from shaft.
3. Remove spacer bushing.
4. Remove horn ring (deluxe wheel) or receiver cup (standard wheel).
5. Remove pivot ring (deluxe wheel) and Belleville spring.
6. Remove contact assembly.
7. Remove steering wheel using puller J-3044-01.

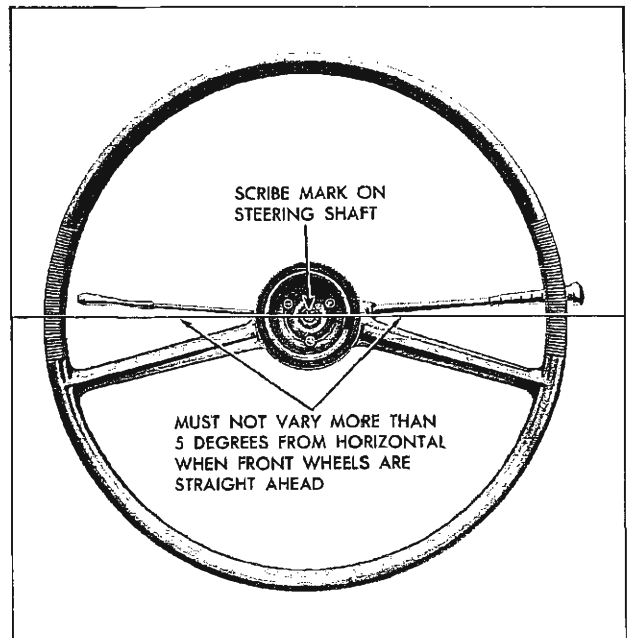

Fig. 9-7 Locating Steering Wheel Position

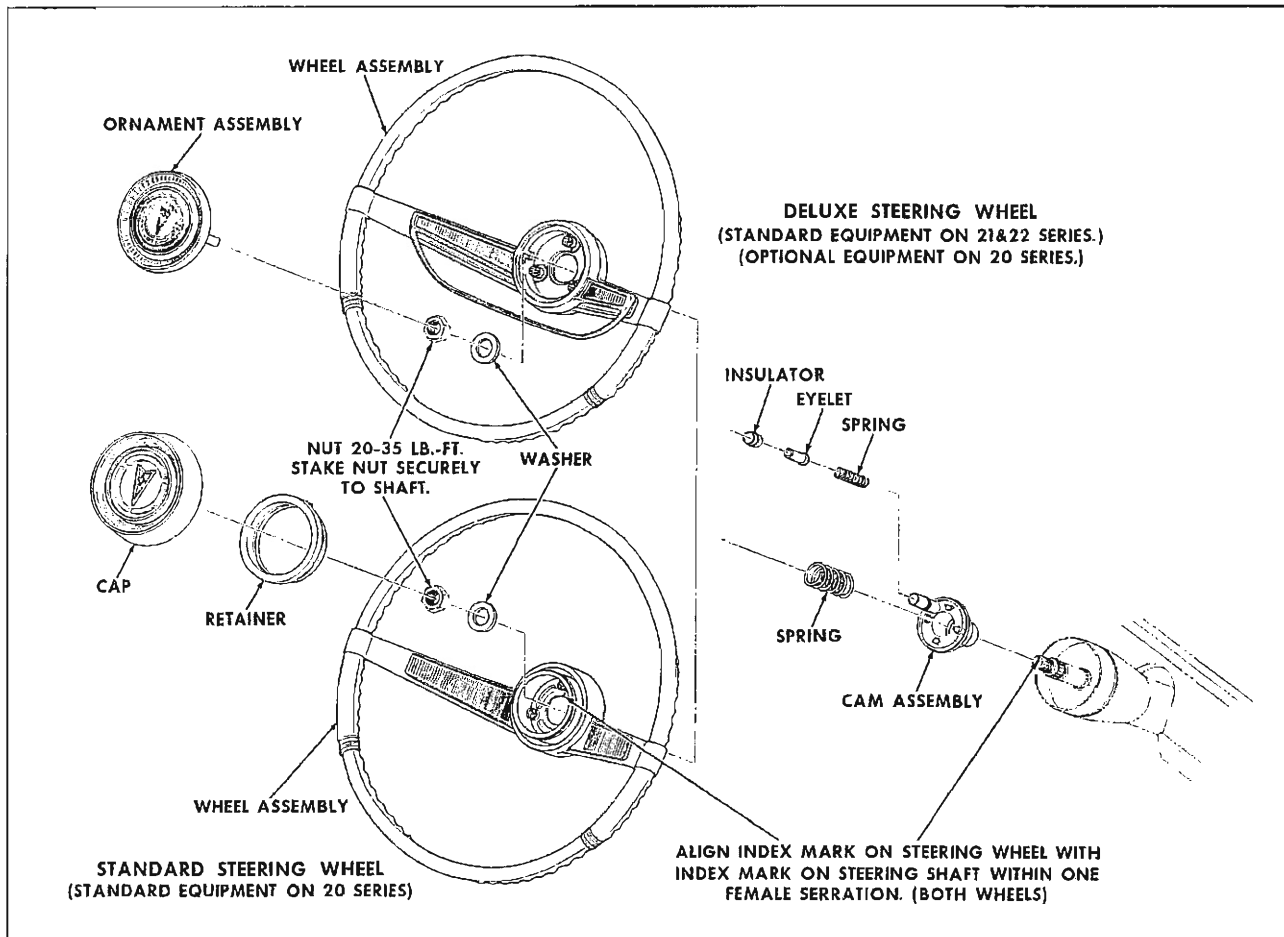

Fig. 9-8 Steering Wheel and Horn Button - Exploded View

8. To replace, reverse the above procedure, making sure steering wheel is in straight ahead position (Fig. 9-7). Tighten steering wheel nut to 20-35 lb. ft. torque and stake.

STEERING COLUMN OVERHAUL

NOTE: Procedure applies specifically to synchromesh (Fig. 9-9). May be used for automatic by referring to Fig. 9-10 and eliminating steps pertaining to synchromesh column.

REMOVE

1. Disconnect first and reverse shifter rod from lower lever and second and third shifter rod from upper lever at steering column.

2. Remove two steering shaft to steering gear retaining bolts.

3. Remove steering wheel as outlined under **STANDARD STEERING WHEEL REMOVE OR DELUXE STEERING WHEEL - REMOVE.**

4. Remove four screws securing toe pan to floor pan.

5. Disengage clutch rod at both ends by removing clips and washers.

NOTE: It is not necessary to loosen clutch rod clevis adjusting nuts to disconnect clutch rod from clutch pedal.

6. Push clutch rod insulator and clutch rod through hole in toe pan.

7. Lift toe pan over end of clutch rod and remove.

8. Disconnect wiring connectors from back-up light switch and directional signal and horn wire connector.

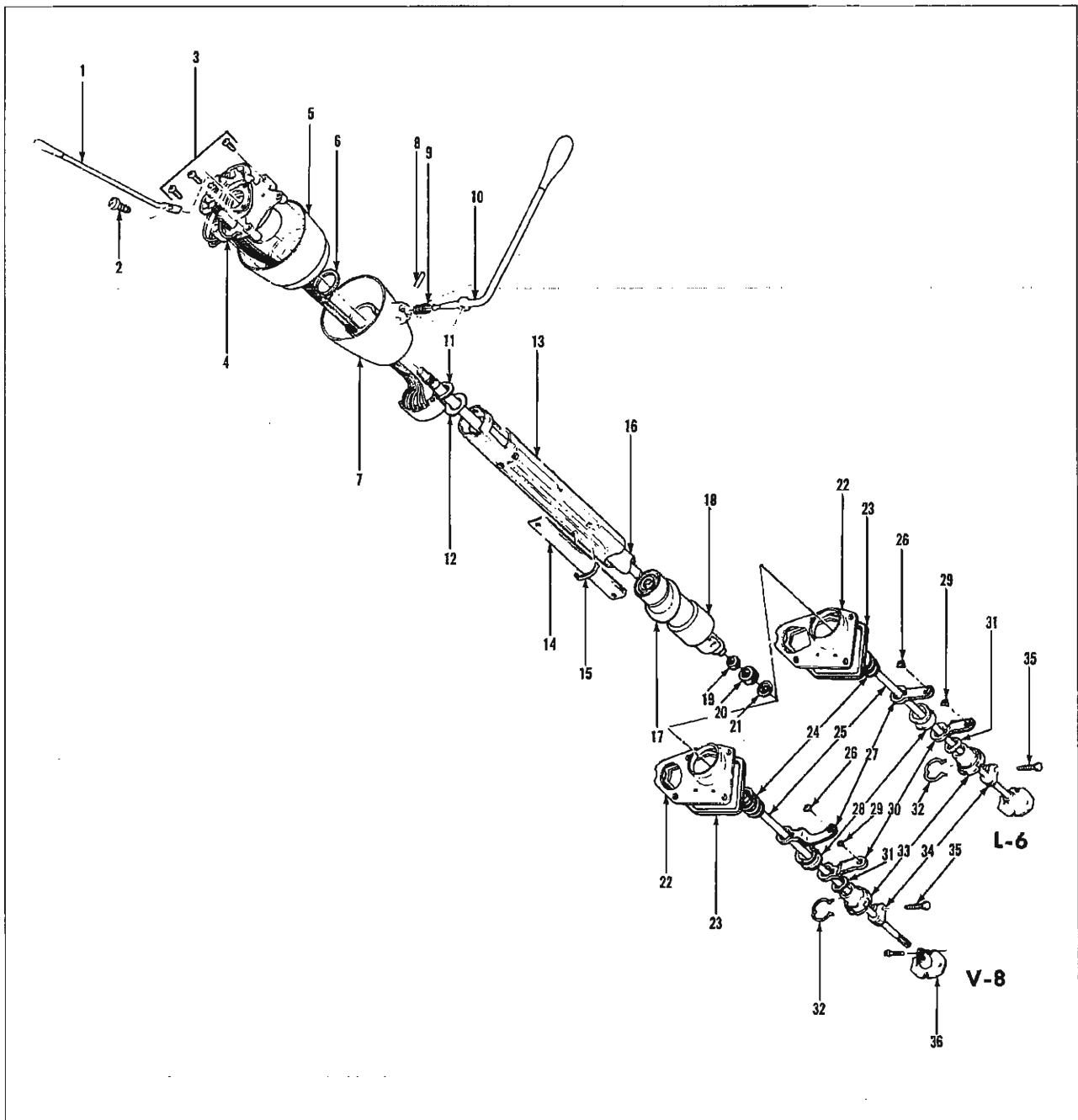

- | | | | |
|---|-----------------------------|---|---|
| 1. Lever Assy. Directional Signal | 6. Washer | 18. Sleeve, Steering Column Jacket | 27. Shift Lever, Second and Third |
| 2. Retaining Screw, Directional Signal Lever #8-32 x 1/2" | 7. Shift Bowl | 19. Seal - Steering Shaft | 28. Spacer, Shift Tube |
| 3. Retaining Screws, Directional Signal Control Assy. | 8. Ping - Shift Lever | 20. Seal - Steering Column Gearshift Tube | 29. Bushing, Shift Lever |
| 4. Control Assy., Directional Signal | 9. Spring - Shift Lever | 21. Seat | 30. Shift Lever, First and Reverse |
| 5. Housing Assy., Directional Signal | 10. Shift Lever | 22. Cover, Steering Column | 31. Washer, Spring |
| | 11. Wave Washer | 23. Seal | 32. Retainer, Lower |
| | 12. Retainer Washer | 24. Spring | 33. Adapter Assy. |
| | 13. Jacket, Steering Column | 25. Shaft, Steering Gear Upper | 34. Clamp, Steering Shaft #14-10 x 1.00 |
| | 14. Cover, Wiring | 26. Bushing, Shift Lever | 35. Screw, Steering Shaft Clamp #14-10 x 1.00 |
| | 15. Retainer, Wiring Cover | | 36. Flange Assy. |
| | 16. Shift Tube | | |
| | 17. Grommet | | |

Fig. 9-9 Steering Column for Synchromesh Transmission - Exploded View

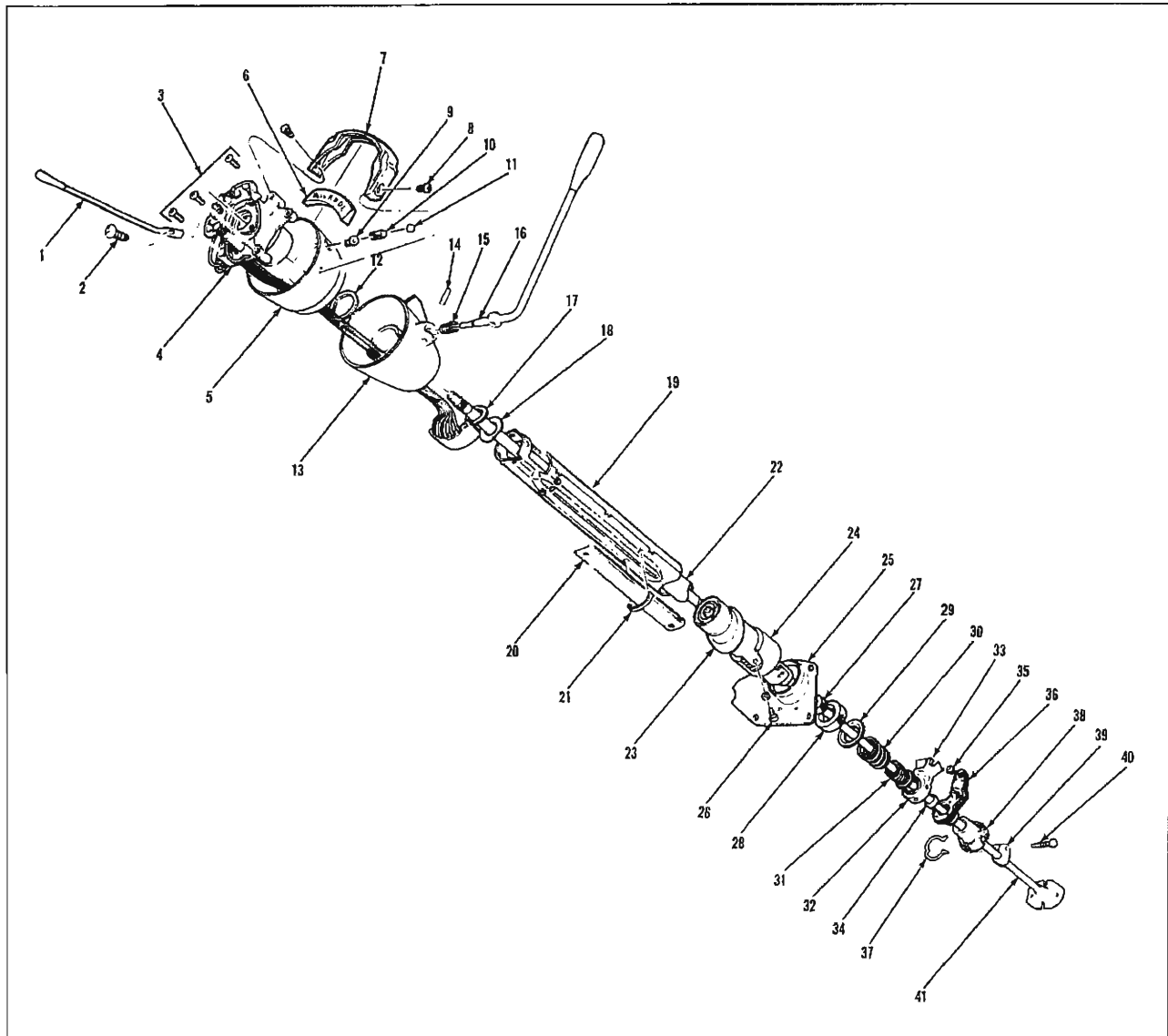

- | | | | |
|---|---|------------------------------------|---|
| 1. Lever Assy. Directional Signal | 8. Screw #8-32 x 1/4" (2) | 20. Cover Steering Column Wiring | 31. Spring |
| 2. Retaining Screw, Directional Signal Lever #8-32 x 1/2" | 9. Lamp | 21. Retainer, Wiring Cover | 32. Seat, Spring |
| 3. Retaining Screws, Directional Signal Control Assy. (3) | 10. Cap | 22. Shift Tube | 33. Control Selector |
| 4. Control Assy., Directional Signal | 11. Filter | 23. Grommet | 34. Sleeve |
| 5. Housing Assy., Directional Signal | 12. Washer | 24. Sleeve, Steering Column Jacket | 35. Bushing |
| 6. Dial, Gearshift Indicator | 13. Shift Bowl | 25. Cover, Steering Column | 36. Lever |
| 7. Retainer, Gearshift Indicator Dial | 14. Pin, Shift Lever | 26. Screw, Hex 1/4-28 x 3/8 (3) | 37. Retainer, Lower |
| | 15. Spring, Shift Lever | 27. Seal, Shift | 38. Adapter Assy. |
| | 16. Lever Assy. Gearshift Control Upper | 28. Seal | 39. Clamp, Steering Shaft |
| | 17. Wave Washer | 29. Seat, Spring | 40. Screw, Steering Shaft Clamp #14-10 x 1.00 |
| | 18. Retainer Washer | 30. Spring | 41. Shaft and Flange, Steering Gear Upper |
| | 19. Jacket, Steering Column | | |

Fig. 9-10 Steering Column for Automatic Transmission - Exploded View

9. Remove two steering column cover plates to instrument panel attaching screws and remove cover plate.

10. Remove two steering column bracket to in-

strument panel attaching screws and washers and remove bracket and insulator.

11. Withdraw entire steering column and shaft assembly.

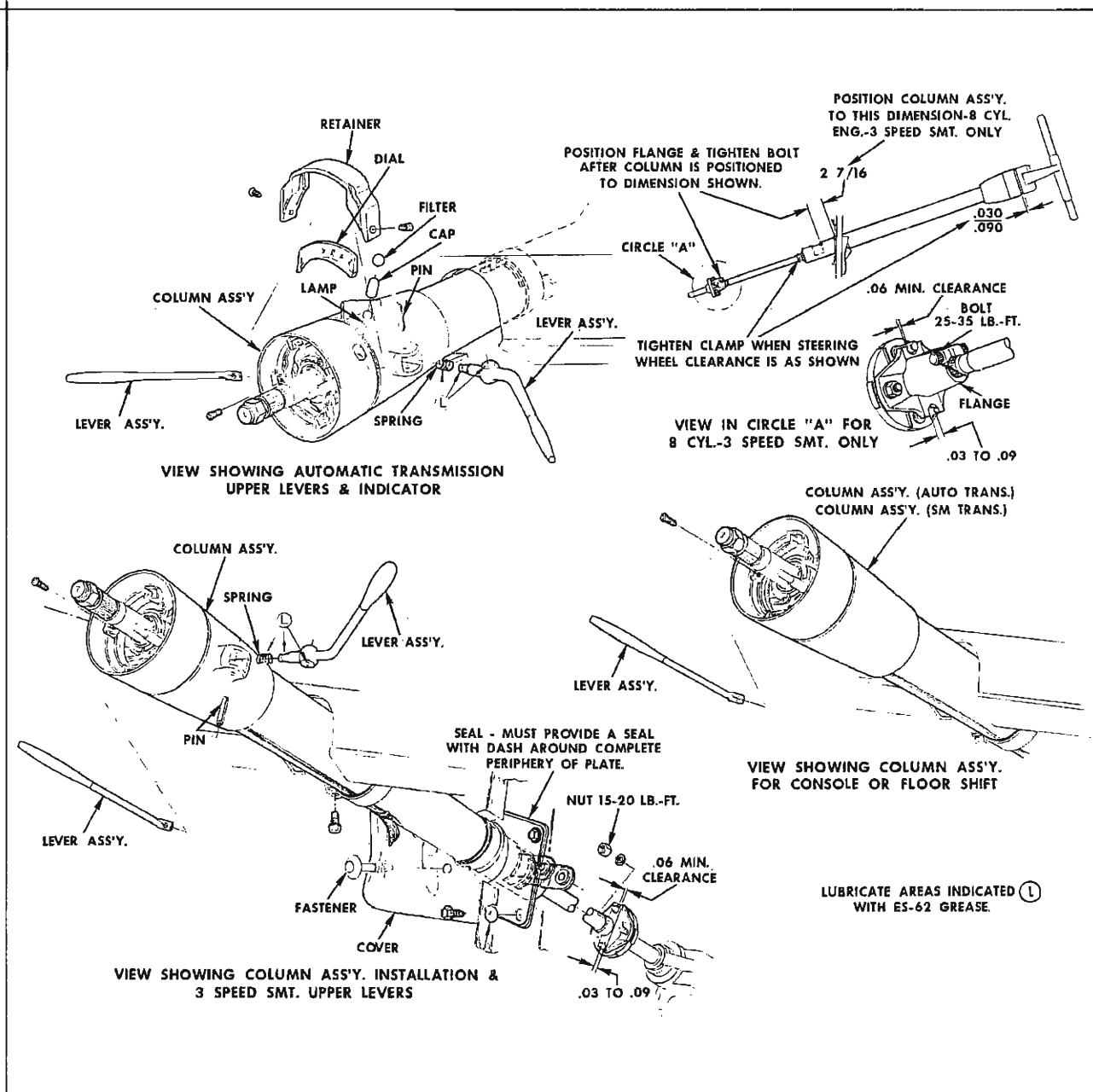

Fig. 9-11 Steering Column and Upper Levers

STEERING COLUMN—DISASSEMBLE

1. Remove retainer from lower end of steering column housing.
2. Remove steering gear shaft lower bearing assembly from steering column assembly.
3. Remove back-up lamp switch from steering column housing.
4. Remove directional signal lever by removing retaining screws.
5. Remove gearshift lever and spring by removing pivot pin.
6. Remove clip and wire cover plate.
7. Remove three retaining screws on upper bearing and directional signal switch. Lift bearing and switch assembly up out of upper bowl.

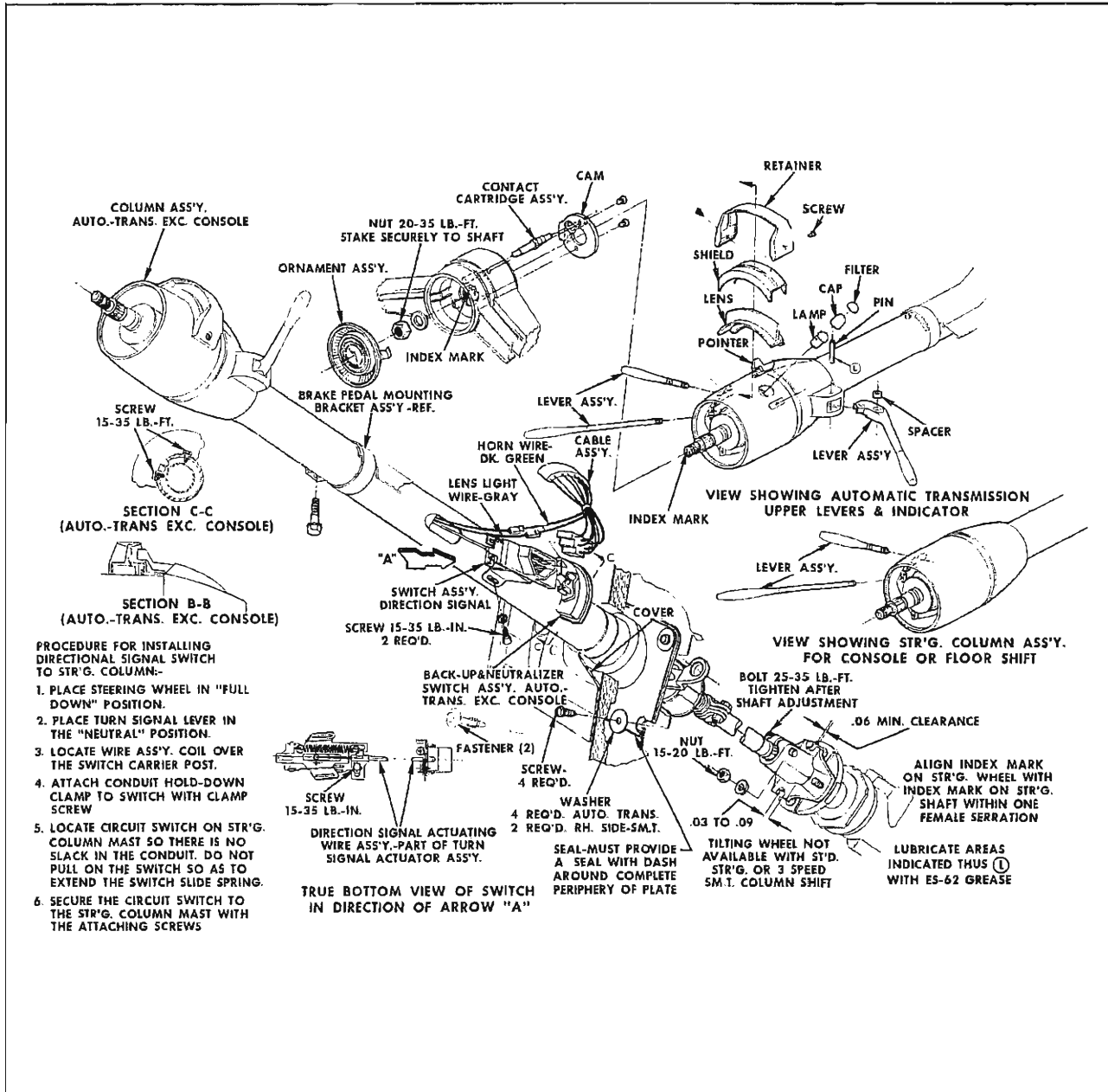

Fig. 9-12 Tilt Steering Wheel Column

8. Rotate directional signal housing counterclockwise and remove.

9. Remove shift bowl by sliding off.

10. Rotate shift tube counterclockwise and remove from upper end of steering column housing. Remove felts from inside and outside of shift tube.

11. Remove shift levers, plastic spacer and wave

washer from lower end of column housing.

STEERING COLUMN - ASSEMBLE (Fig. 9-11)

1. Replace felt spacer on shift tube.

2. Insert shift tube into column housing. (Caution should be taken so as not to damage felt spacer on shift tube.) Index lug on shift tube with slot in column housing.

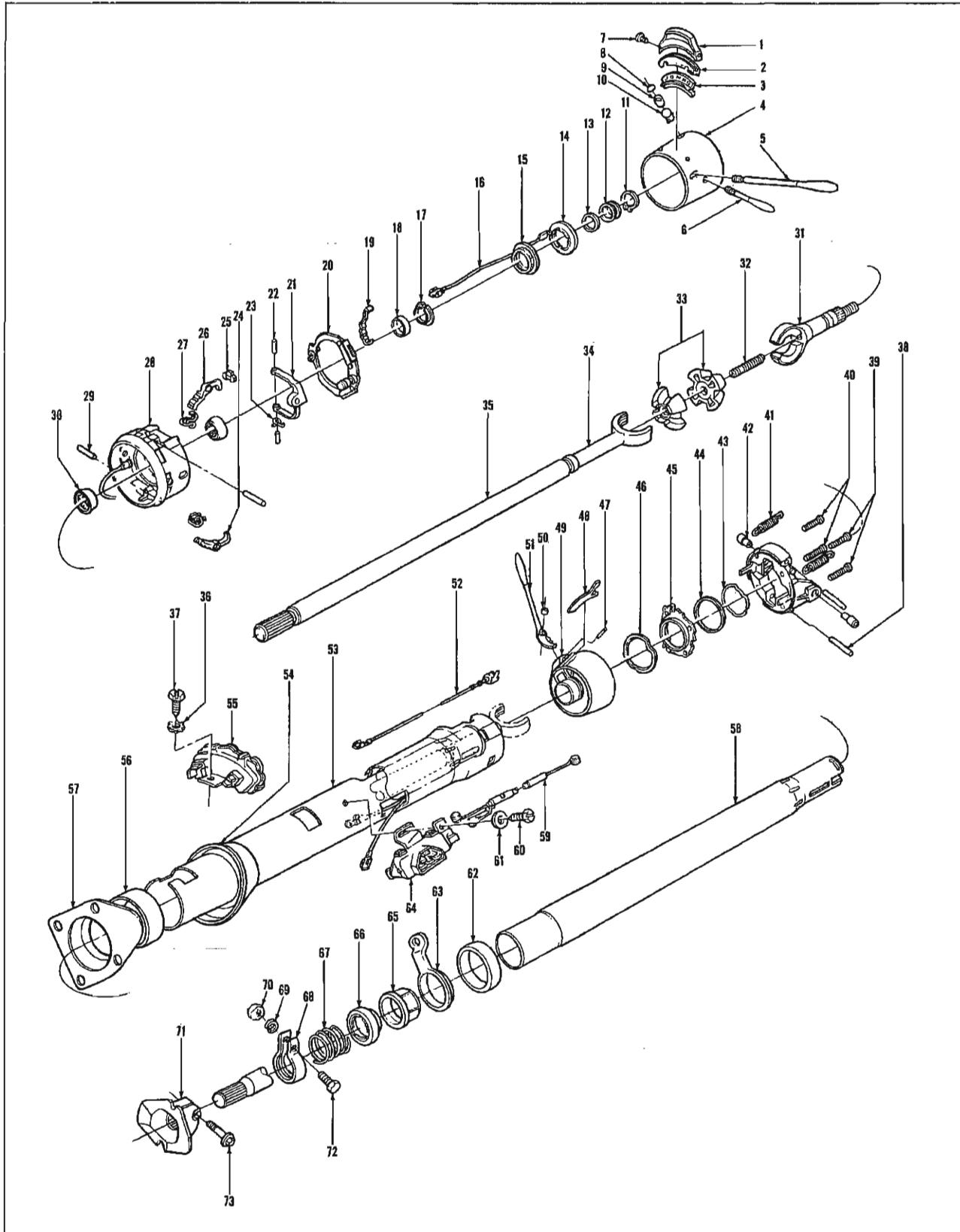

Fig. 9-13 Steering Column with Tilting Wheel - Exploded View

- | | | | |
|--------------------------------------|--|--|---|
| 1. Retainer, Gearshift Indicator | 18. Race, Upper Bearing Inner | 39. Screw (2) | 58. Tube, Gearshift |
| 2. Shield, Gearshift Indicator Lens | 19. Spring Detent | 40. Screw, Support (2) | 59. Wire Assy. Directional Switch Actuating |
| 3. Lens, Gearshift Indicator | 20. Yoke, Actuator | 41. Spring, Tilt Wheel (2) | 60. Screw |
| 4. Cover, Directional Signal Control | 21. Actuator, Shoe Release | 42. Pin, Pivot (2) | 61. Washer |
| 5. Lever, Directional Signal Control | 22. Pin, Actuator (2) | 43. Ring, Shift Tube Retainer | 62. Seal, Steering Column Lower |
| 6. Lever, Tilting Wheel Release | 23. Spring, Actuator | 44. Washer, Bowl Thrust | 63. Lever, Gearshift Lower Shift |
| 7. Screw | 24. Shoe, Lock | 45. Plate, Steering Column Lock | 64. Switch Assy., Directional Signal |
| 8. Filter Shift Indicator Lens Lamp | 25. Stop, Shoe Lock | 46. Washer, Steering Column Wave | 65. Adapter, Steering Column Lower Shift Tube |
| 9. Cap, Shift Indicator Lens Lamp | 26. Shoe, Lock | 47. Pin, Gearshift Lever Fulcrum | 66. Bearing Assy., Steering Shaft |
| 10. Bulb, Indicator | 27. Spring, Lock Shoe (2) | 48. Pointer, Transmission Indicator | 67. Spring, Steering Column Bearing |
| 11. Ring, Bearing Spring Retaining | 28. Housing, Actuator | 49. Bowl, Gearshift Lever | 68. Clamp, Steering Shaft |
| 12. Capsule, Steering Column Preload | 29. Pin, Shoe Dowel (2) | 50. Spacer, Gearshift Lever | 69. Lockwasher, Steering Shaft Clamp |
| 13. Washer, Preload Capsule | 30. Bearing, Steering Shaft Upper (2) | 51. Lever, Gearshift Control Upper | 70. Nut, Steering Shaft Clamp |
| 14. Contact, Horn Button | 31. Shaft, Steering Column Upper | 52. Socket Assy. Transmission Indicator | 71. Flange, Shaft Upper |
| 15. Insulator, Horn Button Contact | 32. Spring, Steering Shaft Joint Preload | 53. Jacket, Steering Column | 72. Bolt, Steering Shaft Clamp |
| 16. Cable, Horn Button Contact | 33. Sphere, Steering Shaft Centering | 54. Grommet, Steering Column | 73. Bolt, Steering Column Shaft Upper Flange to Shaft |
| 17. Seat, Upper Bearing Spring | 34. Yoke, Steering Shaft Coupling | 55. Switch, Neutralizer and Back-Up Lite | |
| | 35. Shaft, Steering Column Lower | 56. Sleeve, Steering Column Jacket | |
| | 36. Lockwasher | 57. Cover, Steering Column to Toe Pan | |
| | 37. Screw, Switch to Jacket | | |
| | 38. Pin, Support (2) | | |

Fig. 9-13 Steering Column with Tilting Wheel - Exploded View

3. Draw shift tube back and insert shift levers, plastic spacer and wave washer in position in lower end of column housing. Push shift tube into place against spring pressure. Rotate clockwise to lock in position.

4. Install washer and wave washer in upper end of column housing.

5. Insert wire loom on upper bearing and directional signal switch through directional signal housing and shift bowl.

6. Position shift bowl on column housing.

7. Install washer on upper end of shift tube.

8. Place upper bowl in position and rotate clockwise to lock in position.

9. Secure upper bearing and directional signal switch with three screws. Torque screws to 20-35 lb. in.

10. Install wire cover.

11. Place lower bearing assembly and felt on steering gear shaft.

12. Start steering shaft into shift tube and push felt into lower opening of shift tube.

13. Place lower bearing in position and install retainer.

14. Replace directional signal selector lever.

15. Replace transmission selector lever.

16. Replace back-up lamp switch.

TILT WHEEL STEERING COLUMN (Figs. 9-12 and 9-13)

DISASSEMBLE

1. Remove turn signal switch from mast jacket by removing two attaching screws and disconnecting turn signal switch control cable.

2. Remove neutral safety and back-up lamp switch assembly from mast jacket.

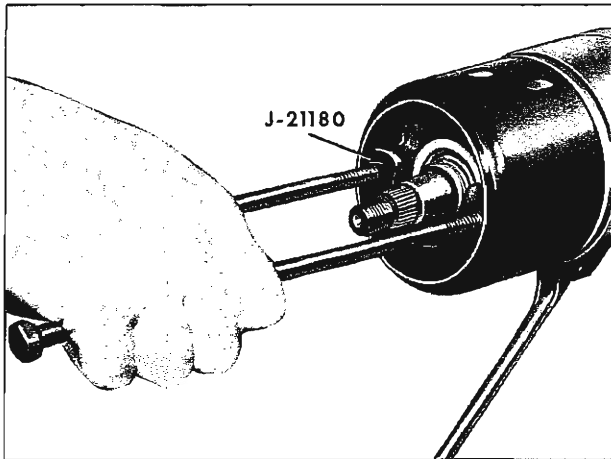

Fig. 9-14 Removing Cover

3. Remove horn button lens by carefully prying up on bezel.

4. Remove three spacer bushing screws, then remove spacer bushing.

5. Remove receiver cup, Belleville spring and horn contact.

6. Remove steering wheel nut, then remove steering wheel, using puller J-3044.

7. Remove turn signal and tilt levers.

8. Remove automatic transmission indicator assembly and bulb.

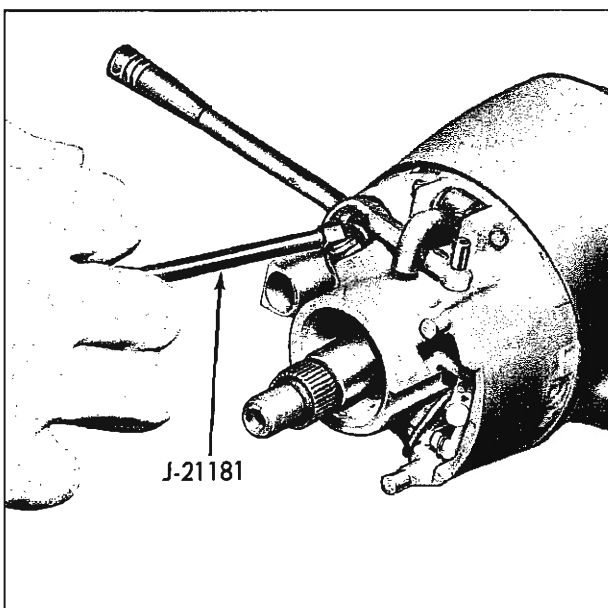

Fig. 9-15 Unseating Springs

9. Pry out horn contact from turn signal actuator housing and let hang loose.

10. Remove turn signal cover with tool J-21180 (Fig. 9-14).

CAUTION: Do not use end of shaft to pull cover as tilt socket in column would be damaged.

11. Remove retainer (Tru-arc snap ring), collapsible spacer, wave washer, retainer, seat, inner race and steering shaft upper bearing.

NOTE: Collapsible spacer must not be reused.

12. Remove turn signal switch actuator yoke and detent spring.

13. Remove bulb socket retaining screw.

14. Install tilt release lever, lift up and allow column to full up position, then unseat upper ends of tilt return springs with tool J-21181 (Fig. 9-15) or screwdriver.

15. Remove two pivot pins with tool J-21179 (Fig. 9-16).

16. Disconnect turn signal cable from retainer assembly.

17. Lift tilt lever to disengage lock shoes from pins and remove actuator assembly.

18. Remove tilt springs.

19. Remove horn contact from actuator assembly.

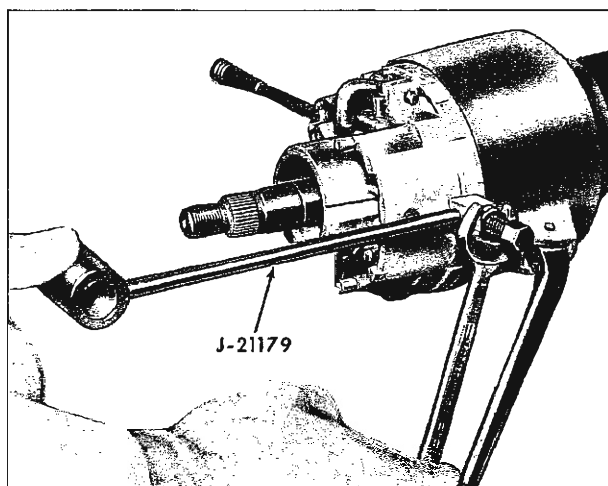

Fig. 9-16 Removing Pivot Pins

20. Drive lock shoe pivot pins from actuator, then remove lock shoes and springs.

NOTE: Upper shoe has rubber bumper.

21. Remove actuator spring pins and lever.

22. Remove steering shaft coupling assembly from lower end of steering shaft.

23. Remove lower bearing retaining clamp and spring.

24. Remove steering shaft assembly upward through mast jacket.

25. Remove four support screws and support from mast jacket.

26. Remove turn signal switch control cable by pulling core rearward and twisting cable assembly so that opposite end is removed from steering column jacket.

27. Remove shift tube retainer ring washer from top of shift tube.

28. Remove shift tube bearing retainer from lower end of mast jacket.

29. Remove shift tube downward through column by tapping against bore of lower shift lever.

30. Remove lock plate, wave washer and bowl from upper end of mast jacket.

31. Drive shift lever pivot pin from bowl, then remove shift lever.

ASSEMBLE

When assembling steering column, apply thin coat of lithium soap grease to all friction parts.

1. Place shift lever spring and lever in bowl, then install lever pin.

2. Install bowl on mast jacket, then wave washer over mast jacket and slide lock plate into position through opening in mast jacket.

3. Install shift tube assembly with felt seal into mast jacket from lower end of jacket.

4. Install thrust washer and retaining ring on upper end of shift tube.

NOTE: Do not connect cable to bell crank.

5. Install support on upper end of mast jacket and install four attaching support screws. (The two larger screws go into left-hand holes in support. Torque larger left-hand screws first.) Torque 30-40 lb. in. into upper steering shaft.

6. Install steering shaft assembly into mast jacket from upper end.

7. Install lower bearing in bottom of mast jacket.

8. Install spring and lower bearing retaining clamp on steering shaft.

9. Install steering shaft coupling assembly on lower end of shaft.

10. Install lower roller bearing at steering wheel end of steering shaft.

11. Install actuator lever, pins, and spring on actuator assembly.

12. Install release springs on upper end of lock shoes, then install shoes in actuator and retain with pivot pins.

NOTE: The upper lock shoe must have rubber bumper installed.

13. Install lower ends of two return springs on support spring anchor.

14. Connect turn signal switch control on ball crank in turn signal actuator, mounting cable loop inboard. Install cable bracket screw.

15. Install tilt lever into tilt release actuator.

16. Assemble horn contact and wire through actuator assembly and mast jacket.

17. Move tilt lever up slightly to prevent lock shoes from engaging pins, then install actuator assembly over steering shaft.

18. Align actuator assembly pivot pin holes with pin holes in support assembly and install pivot pins.

19. Raise tilt lever and lift upper steering column to maximum up position.

20. Install upper ends of two return springs with tool J-21181, spring installer.

21. Install turn signal actuator yoke assembly and detent spring.

CAUTION: Check to be sure bell crank is engaged in bracket of yoke assembly.

22. Install upper steering shaft bearing, inner race, seat, retainer, wave washer, and new collapsible spacer.

23. Install snap ring (Tru-arc) over steering shaft and against collapsible spacer, then place tool J-21179 and 9/16" I.D. washer over steering shaft.

24. Install the steering wheel nut and turn down until window (cut-out) in tool J-21179 is in line with upper edge of snap ring groove (.002") (Fig. 9-17).

25. Remove the steering wheel nut and tool J-21179, tapping snap ring into groove.

26. Check torque of steering shaft, making sure torque is 40 ounce inches plus or minus 5 ounce inches in all tilt positions.

NOTE: If torque is below specifications, spacer has been over collapsed.

27. Remove tilt wheel release lever.

28. Install turn signal cover, aligning key in cover into keyway in turn signal actuator.

29. Install tilt and turn signal levers.

30. Replace bulb and indicator assembly.

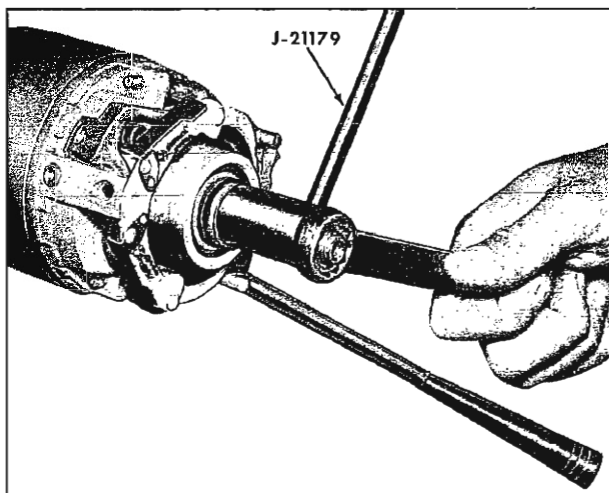

Fig. 9-17 Seating Spacer

31. Install steering wheel.

32. Install neutral safety and back-up lamp switch lever and switch on mast jacket.

33. With upper turn signal actuator in center position, place loop in control cable over switch carrier pin and connect control cable to switch. Index steering wheel to full down position and mount switch to jacket with two screws.

CENTERING SPHERE - DISASSEMBLE

1. Remove the spring from between steering shaft couplings (sockets) in the following manner:

CAUTION: When removing spring, use care to prevent losing spring since it is under compression.

a. Turn upper shaft slightly from centerline of lower shaft.

b. Using narrow bladed screwdriver, compress spring enough to remove it from upper seat, then remove spring.

2. Turn upper shaft 90° from centerline of lower shaft and remove shaft over flats of centering sphere (Fig. 9-18).

3. Remove sphere from upper shaft by rotating so flats on sphere align with socket.

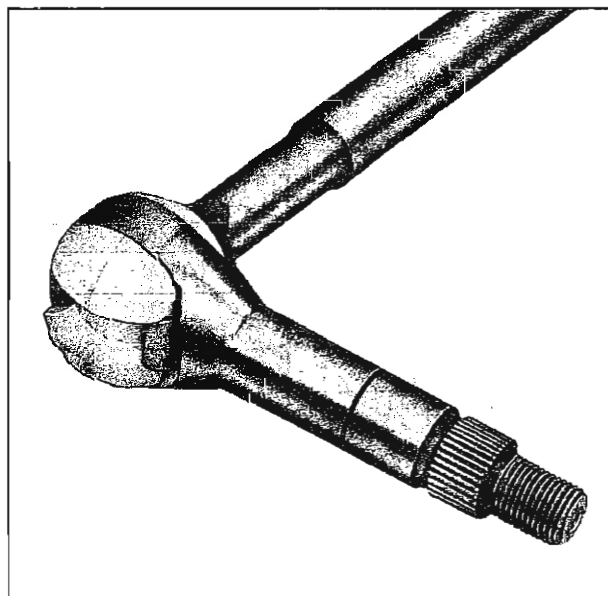

Fig. 9-18 Separating Upper and Lower Shaft

CENTERING SPHERE - ASSEMBLE

1. Place centering spheres in upper shaft socket.
2. Turn spheres so lower shaft can be installed over flat area of spheres. (Approximately 90° from centerline of lower shaft.) Then install lower shaft socket over sphere.
3. Install spring through centering sphere into lower shaft and into upper steering shaft.

STEERING COLUMN—INSTALL

1. Insert lower end of steering column assembly through opening in floor of vehicle, lowering column until steering shaft flange and steering gear housing meet.
2. Install instrument panel bracket and insulator around steering column and insert attaching screws and washers, but do not tighten.
3. Securely tighten steering shaft to steering gear retaining bolts.
4. Install steering wheel as outlined under **STANDARD STEERING WHEEL - REPLACE** or **DELUXE STEERING WHEEL - REPLACE**.
5. On all but V-8 synchromesh, when steering wheel is drawn down to 1/16" of directional signal housing, tighten steering column bracket to instrument panel attaching screws. Adjust clamp on steering gear shaft up against lower bearing assembly and tighten.
6. On V-8 synchromesh adjust steering column so that there is 2-7/16" between the upper edge of the shift lever opening in the steering column housing and the cowl panel (Fig. 9-11). Tighten steering column bracket to instrument panel attaching screws. When steering wheel is drawn down to 1/16" of directional signal housing, tighten flange bolt on flexible coupling. Adjust clamp on steering gear shaft against lower bearing assembly and tighten.
7. Install steering column cover plate and attach with two screws.
8. Insert clutch rod through hole in toe pan and position toe pan around steering column.
9. Install clutch rod insulator through hole in toe pan so that clutch rod is held firmly.
10. Insert four toe pan retaining screws and tighten securely.
11. Position rubber grommet against toe pan.
12. Engage clutch rod with clutch pedal and insert cotter pin.

NOTE: If clutch rod clevis adjusting nuts were not loosened during disassembly, clutch pedal height will probably be correct.

13. Connect wiring connector at back-up light switch, directional signal and horn wire connector.

14. Connect first and reverse shifter rod to lower lever and second and third shifter rod to upper lever at steering column.

15. Adjust clutch (Section 6).

REPLACE STEERING LINKAGE

Steering connecting rod may be removed from both tie rods, pitman arm and idler arm by removing the ball shaft nut (Fig. 9-4). Since the connecting rod is a solid shaft, it may be replaced by installing new rod and connecting to pitman arm, tie rods, and idler arm.

After steering connecting rod is removed, pitman arm may be removed from pitman shaft by removing the nut and lock washer and by using puller J-5504. To install pitman arm on pitman shaft, replace arm, lock washer and nut and tighten to 100-125 lb. ft. torque.

After steering connecting rod is removed, idler arm may be removed by removing two bolts which retain idler support to frame. The idler support and idler arm may then be separated, first threading idler support from bushing and then threading the idler arm from bushing. In reassembling, install bushing in idler arm and tighten to 100 lb. ft. torque. Next thread idler support and seal into bushing until distance between idler arm support lower mounting bolt hole and top of arm is approximately 2.96". Install assembly on frame with two attaching bolts and tighten to 35-45 lb. ft. torque.

Tie rod assembly may be removed from car by removing cotter pin and castellated nut on tie rod ends at steering arms. To separate tie rod and tie rod end, loosen two bolts on tube and clamp assembly, and thread out the part to be replaced. To reassemble, thread new part into tube and clamp

assembly to approximate original location, place tie rod end with dust cover in steering arm, tighten castellated nut securely, and install new cotter pin.

When new tie rods or tie rod ends are installed it is necessary to check toe-in. Check clamp bolts on tie rod adjuster sleeve assembly for tightness (14-20 lb. ft. torque) and make sure bolts are to lower rear and at 45° angle from horizontal with nuts in up position (Fig. 9-4).

Whenever work is done on steering linkage it should be lubricated.

STEERING GEAR—REMOVE

1. Disconnect pitman arm from pitman shaft, using J-5504.
2. Scribe a mark on the worm shaft flange and steering shaft and disconnect lower flange from steering shaft.
3. Remove three steering gear housing to frame bolts.

STEERING GEAR—DISASSEMBLE

Disassemble and reassemble steering gear and sub-assemblies on a clean work bench, preferably while the assembly is mounted on holding fixture (J-5205 or J-6448-01).

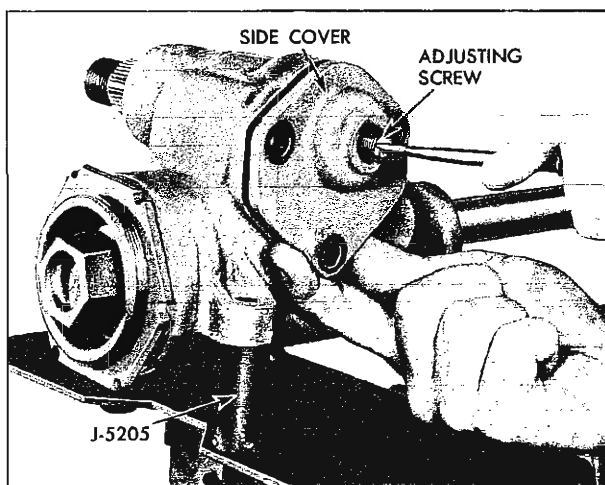

Fig. 9-19 Removing Side Cover

CAUTION: DO NOT clamp housing in vise. Cleanliness is of utmost importance; therefore, bench tools, and parts must be kept clean at all times.

Before disassembling gear, thoroughly clean exterior with suitable solvent and drain as much fluid as possible. Assist draining by turning gear flange through its entire range two or three times.

1. Mount steering gear assembly on holding fixture J-5205.
2. Rotate worm shaft with lower flange assembly until wheel is in center of travel. Remove three side cover screws and adjusting screw nut.
3. Remove side cover and gasket by turning adjusting screw clockwise through cover (Fig. 9-19).
4. Remove adjusting screw from slot in end of pitman shaft. Make sure shim found on adjusting screw remains with screw (Fig. 9-20).
5. Remove pitman shaft from housing, using care that threads do not damage seal in housing.
6. Loosen worm bearing adjuster lock nut with brass drift and remove adjuster and lower bearing.
7. Remove lower flange assembly.
8. Push worm and shaft assembly, with ball nut assembly, through bottom of housing and remove upper bearing.
9. Clean grease from worm and shaft assembly and also from inside gear housing.
10. Remove ball nut return guide clamp by removing three screws, remove guides, turn ball nut over and remove balls. Rotating shaft slowly from side to side will aid in removing balls.

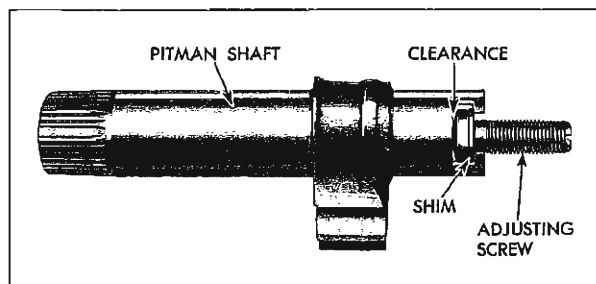

Fig. 9-20 Pitman Shaft and Adjusting Screw

11. Remove ball nut from worm.

NOTE: Unless all balls are removed, nut cannot be removed.

CLEANING AND INSPECTION

1. Remove gear housing from holding fixture.
2. Wash all parts in clean kerosene or other suitable solvent.
3. Inspect all bearings, bearing cups, worm groove, bushings, seals, teeth for scoring, wear, pitting, etc., which would necessitate replacement.

4. Inspect housing and cover for sand holes or cracks.

If pitman shaft bushing seal, upper and lower bearing cups, steering gear housing or column jacket are worn excessively or damaged, replace parts.

REPLACE PITMAN SHAFT BUSHING

1. Remove pitman shaft seal.
2. Drive out bushing with tool J-1614 (Fig. 9-22).
3. To install new bushing with same tool, driving bushing in towards center of gear housing, inner end of bushing must be flush with inside surface of housing at the seal seat.

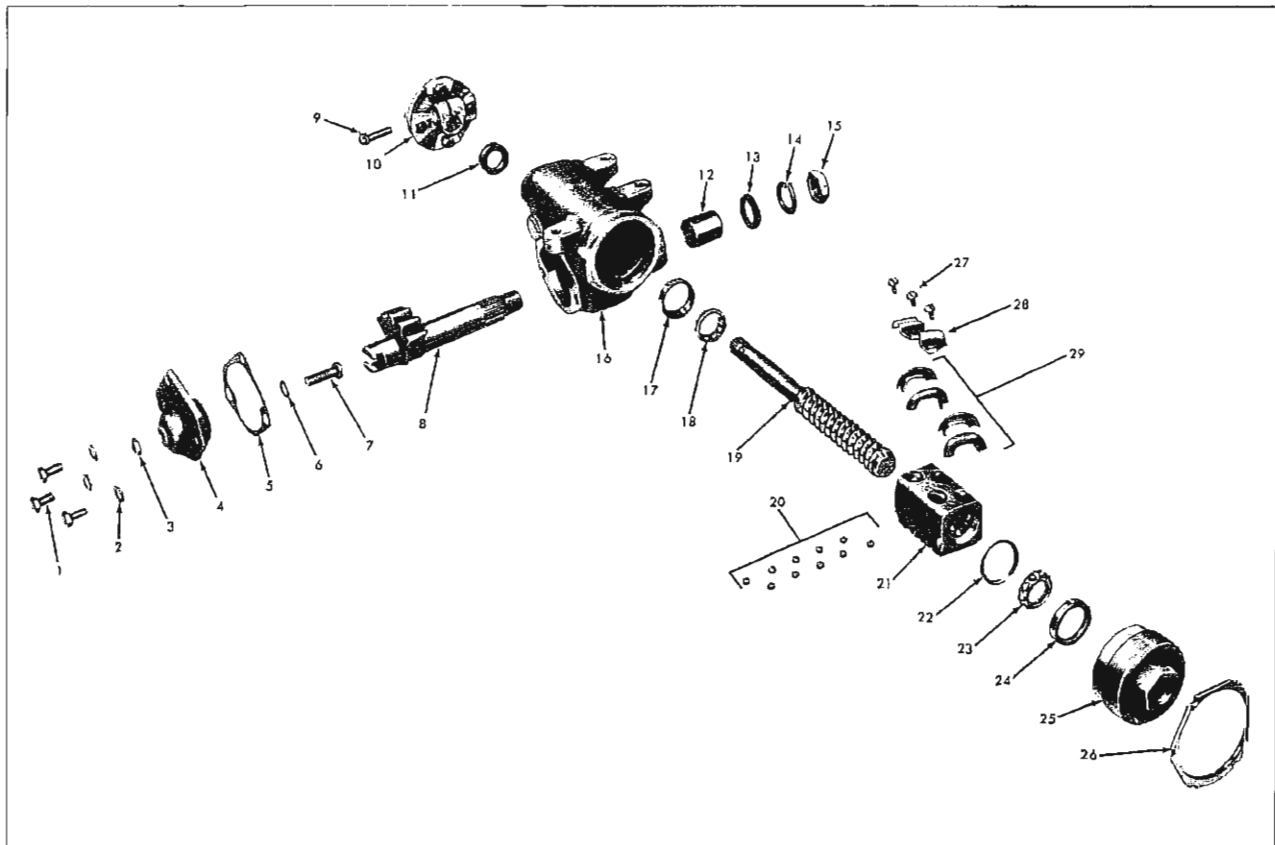

1. Side Cover Bolts
2. Side Cover Bolt Washers
3. Adjusting Screw Lock Nut
4. Side Cover
5. Side Cover Gasket
6. Adjusting Screw Shim
7. Adjusting Screw
8. Pitman Shaft
9. Flange Assembly Bolt
10. Coupling and Lower Flange Assembly

11. Steering Shaft Seal
12. Pitman Shaft Bushing
13. Pitman Shaft Seal
14. Pitman Shaft Nut Lock Washer
15. Pitman Shaft Nut
16. Steering Gear Housing
17. Upper Bearing Cup
18. Upper Bearing
19. Worm and Steering Shaft
20. Balls

21. Ball Nut
22. Lower Bearing Retainer
23. Lower Bearing (Worm Thrust)
24. Lower Bearing Cup (Worm Thrust)
25. Worm Bearing Adjuster Lock Nut
26. Worm Bearing Adjuster
27. Ball Return Guide Clamp Screws
28. Ball Return Guide Clamp
29. Ball Return Guides

Fig. 9-21 Standard Steering Gear—Exploded View

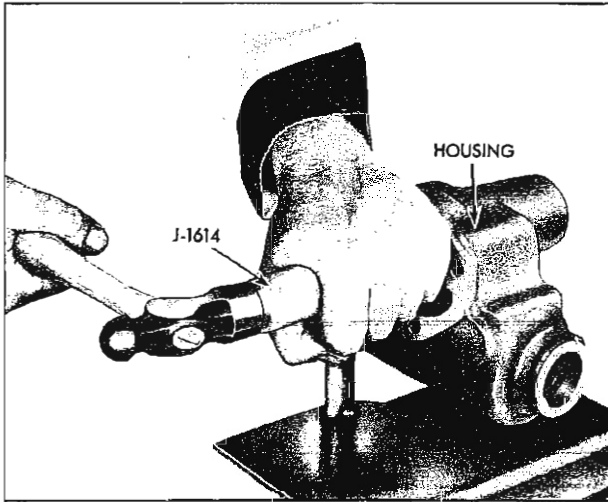

Fig. 9-22 Removing Pitman Shaft Bushing

4. Install new pitman shaft seal, using suitable socket as driver.

REPLACE PITMAN SHAFT SEAL

1. Remove pitman shaft seal with screwdriver or suitable tool.
2. Install new seal, using suitable socket as driver.

REPLACE UPPER OR LOWER BEARING CUPS

UPPER CUP

Remove gear housing upper seal assembly. Then using suitable punch, remove upper cup from gear

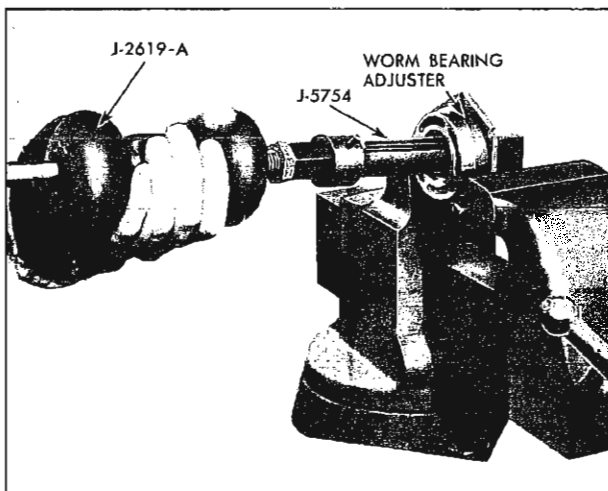

Fig. 9-23 Removing Bearing Cup from Worm Bearing Adjuster

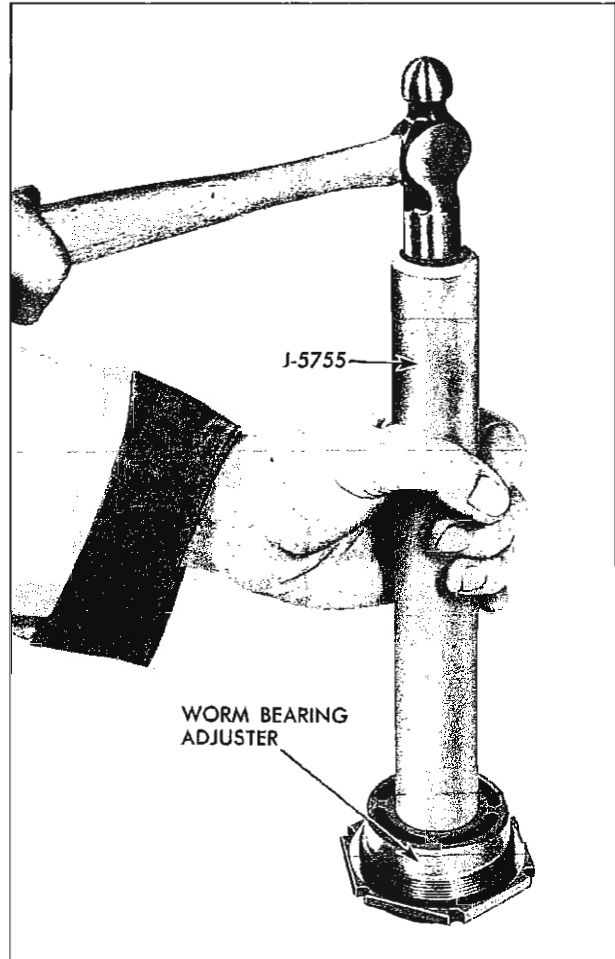

Fig. 9-24 Replacing Bearing Cup

housing. Install bearing cup in housing, using J-5755. Replace seal.

LOWER CUP

1. Remove lower cup from worm bearing adjuster (Fig. 9-23), using tool J-5754 and J-2619B slide hammer.
2. Install bearing cup in worm bearing adjuster (Fig. 9-24), using tool J-5755.

STEERING GEAR ASSEMBLE

NOTE: All seals, bushings and bearings should be prelubricated before assembly.

1. Position ball nut on shaft so that deep side of teeth are located as shown in Fig. 9-25.

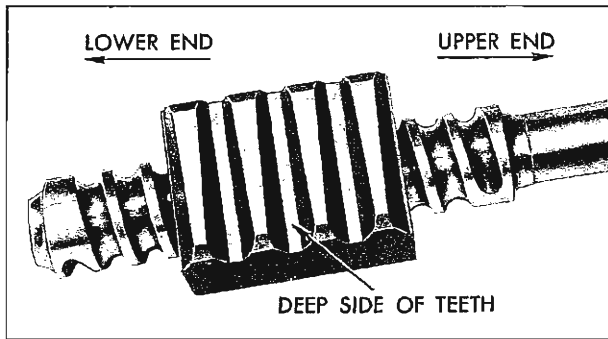

Fig. 9-25 Ball Nut Properly Installed on Shaft

2. Install 19 balls in each circuit of ball nut (rock steering shaft slightly to aid in installing balls) and insert 6 balls in each return guide, using petrolatum to hold balls in place. Install return guide clamp and screw.

CAUTION: Do not rotate worm shaft while installing balls, since balls may enter crossover passage between circuits. This will cause improper operation of ball nut.

3. Place upper bearing on worm shaft. Center ball nut on worm, then slide worm shaft, bearing and nut into housing.

4. Place lower bearing in worm adjuster and install bearing retainer over bearing, using J-5813. Install adjuster in housing.

NOTE: Adjuster should be installed just tight enough to hold bearing races in place. Install adjuster lock nut loosely.

5. Slip lower flange assembly on shaft and turn steering gear from one extreme to the opposite to make certain there are no unusual binds and remove flange assembly.

NOTE: Never allow ball nut to strike the ends of the ball races in worm due to the possibility of damage to ball guides.

a. Using a 11/16"-12 point deep socket and inch pound torque wrench, measure torque required to keep wrench in motion when off high point of gear. Torque required should be 5 to 9 lb. in.

b. If torque does not meet above specifications, loosen worm bearing adjuster lock nut (Fig. 9-26) and turn adjuster to bring torque within 5 to 9 lb. in. limits.

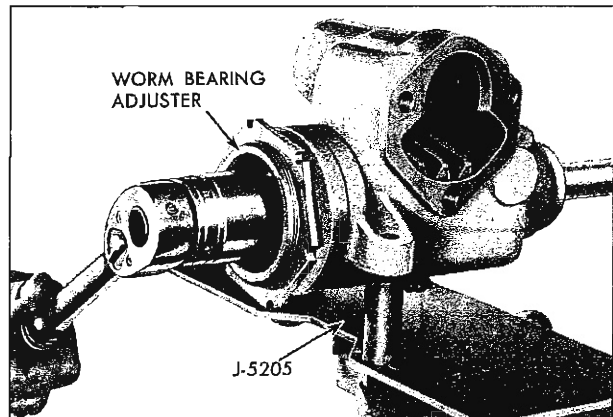

Fig. 9-26 Adjusting Worm Bearing Preload

c. Tighten lock nut and recheck torque.

d. Remove 11/16" socket and torque wrench.

6. Install pitman shaft adjusting screw and selective shim in pitman shaft (Fig. 9-27).

NOTE: Screw must be free to turn, but have no more than .002" end play. If end play of screw in slot is too tight or too loose, select new shim to give proper clearance. Shims are furnished in four thicknesses: .063", .065", .067", and .069".

7. Position pitman shaft seal on pitman shaft and seat seal, using suitable socket as a driver.

8. Install pitman shaft and adjusting screw with sector and ball nut teeth positioned as shown in Fig. 9-28.

9. Install side cover and gasket on adjusting screw, turning screw counterclockwise until it projects through cover 5/8" to 3/4".

10. Install two cover attaching bolts. Tighten to 25 to 40 lb. ft.

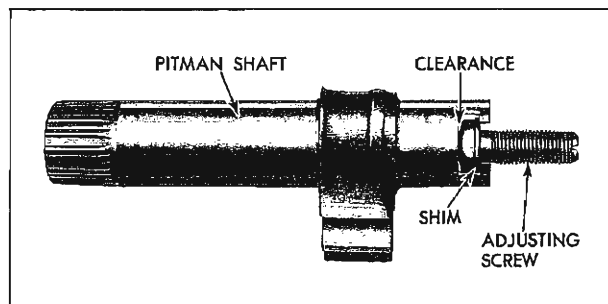

Fig. 9-27 Pitman Shaft and Adjusting Screw

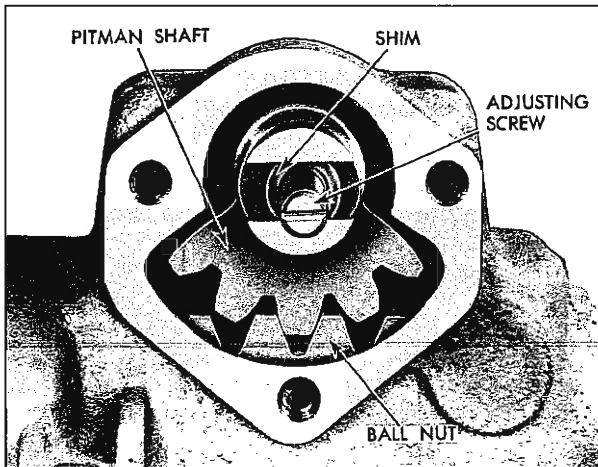

Fig. 9-28 Positioning Pitman Shaft and Ball Nut

11. Tighten pitman shaft adjusting screw so that teeth on shaft and ball nut engage but do not bind. Final adjustment will be made later.

12. Fill steering gear with all-season steering gear lubricant and install third cover attaching bolt. Tighten to 25 to 40 lb. ft.

13. Adjust sector preload and ball nut backlash as follows:

a. Place a 11/16"-12 point socket and lb. in. torque wrench over end of worm shaft.

b. Tighten pitman shaft adjusting screw as necessary to obtain a reading of 4 to 9 lb. in. torque, in excess of thrust bearing preload, when the worm gear is turned through the high point (Fig. 9-29).

c. Tighten pitman shaft adjusting screw lock nut to 18 to 27 lb. ft. and recheck adjustment.

STEERING GEAR—INSTALL

1. Align scribe marks on steering and worm shaft flange.

2. Position steering gear assembly in car.

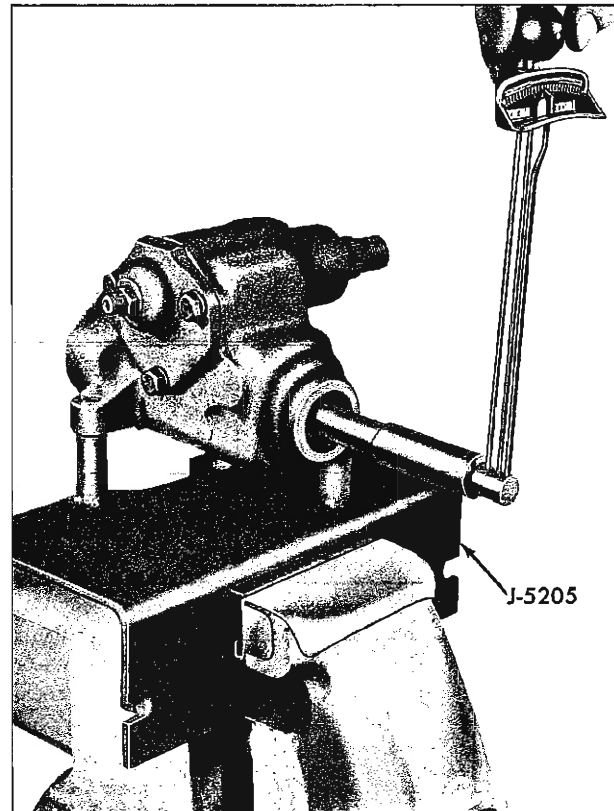

Fig. 9-29 Adjusting Worm Gear Through High Point

NOTE: Metal-to-metal contact between flanges on stub shaft assembly and steering shaft assembly will transmit and amplify gear noise to driver.

3. Install steering housing to frame bolts and tighten housing to frame bolts to 55-75 lb. ft. torque.

4. Install pitman arm and secure with lock washer and nut. Tighten nut to 110-140 lb. ft. torque.

5. Install two flange attaching nuts and lock washers and tighten to 15-20 lb. ft. torque.

6. Align steering column jacket and shaft assembly and steering gear so head of lower coupling bolt has 1/4-inch clearance from flange on steering shaft. Adjust the steering mast jacket assembly up or down. A metal to metal contact at this point will transmit the slightest noise to the driver.

7. Be sure pins are properly positioned.

STEERING GEAR TROUBLE DIAGNOSIS

(See SUSPENSION TROUBLE DIAGNOSIS AND TESTING, Section 3, for Additional Information.)

CONDITION	CAUSE	REMEDY
Hard steering while driving	Frozen steering shaft bearings	Replace bearings
	Lower coupling flange rubbing against steering shaft	Loosen bolt and assemble properly
	Steering wheel rubbing against gearshift bowl	Adjust jacket endwise
	Steering gear or connection adjustment too tight	Check adjustment by dropping pitman arm from gear or disconnecting linkage from pitman arm ball. Readjust if necessary
	Front spring sagged	Check front end jounce height. Jounce height should be approximately the same at both wheels. Compare dimensions with those on car having about same mileage and equipment and believed to be standard. Replace front springs if sagged
	Frame bent or broken	Repair frame as necessary
	Steering knuckle bent	Install new buckle
	Ball joint galled or too tight	Replace ball joint
	Low or uneven tire pressure	Inflate tires to recommended pressure
	Steering gear or connections adjusted too tight	Test steering system for bind with front wheels off floor. Adjust, as necessary, and lubricate
	Insufficient or incorrect lubricant	Check lubricant in steering gear and lubricate steering system as required
	Excessive caster	Check caster and adjust as necessary
	Suspension arms bent or twisted	Check camber and caster. If arms are out of car, compare with new arms and replace if bent

CONDITION	CAUSE	REMEDY
Poor return of steering	Frozen steering shaft bearings	Replace bearings
	Lower coupling flange rubbing against steering shaft	Loosen bolt and assemble properly
	Steering wheel rubbing against gearshift bowl	Adjust jacket endwise
	Tires not properly inflated	Inflate to specification
	Incorrect caster or toe-in front wheels	Adjust to specification
	Tight steering linkage	Lubricate - check end plugs
	Tightness of suspension ball joints	Lubricate
	Steering adjustment tight	Check adjustment by dropping pitman arm from gear or disconnecting linkage from pitman arm ball. Readjust if necessary
	Tight sector to worm nut adjustment	Adjust in car to specification
	Worm bearing adjustment too tight	Remove gear and adjust to specification
Car leans to one side or the other	Nut and worm preload too tight	Remove gear and replace balls as required
	Due to front end misalignment	Adjust to specification
Excessive wheel kickback or loose steering	Lash in steering linkage	Adjust parts affected
	Excessive lash between pitman shaft sector and nut	Adjust to specification
	Ball nut and worm preload	Check worm bearing adjustment and overcenter adjustment. Check for looseness in steering linkage. If complaint still exists, remove rack piston and worm, and change balls to obtain specified preload
	Ball joints too loose	Replace ball joints
	Front wheel bearings incorrectly adjusted or worn	Adjust and/or replace front wheel bearings
Hard steering when parking	Lack of lubrication in linkage or front suspension	Add lubricant where needed
	Tires not properly inflated	Inflate to recommended pressure

SPECIFICATIONS

Type	Saginaw Recirculating Ball Nut	Worm Bearing Preload	5-9 lb. in.
Steering Gear Ratio Overall	28.32:1	Sector and Ball Nut Back	
Lubricant	See Lubrication Section	Lash	Worm Bearing Preload plus 4-9 lb. in.
Lubricant Capacity	11 Fluid Ounces	(Total Thrust Bearing Adjustment, Pitman Shaft Adjustment, and Drag not to exceed 14 lb. in.)	

WRENCH TORQUE SPECIFICATIONS

(Torque in lb. ft. unless otherwise specified.)

TORQUE	APPLICATION
	Steering Gear and Pitman Arm
55-75	Bolt - Steering Gear Assembly to Frame
110-140	Nut - Pitman Arm Shaft (Standard Steering)
	Steering Wheel
20-35	Nut - Steering Wheel to Steering Column Shaft
	Steering Column Bracket
10-35 Lb. In.	Nut - Steering Column Upper Bracket to Instrument Panel
10-20	Screw - Steering Column Lower Bracket to Mtg. Bracket
10-35 Lb. In.	Screw - Steering Column Opening Cover Plate to Floor
10-20	Bolt - Steering Column Shaft Jacket Lower Clamp
	Steering Linkage
*	Fitting - Steering Gear Connecting Rod Lubrication
*	Fitting - Steering Knuckle Tie Rod Ball Lubrication
14-20	Bolt and Nut - Steering Knuckle Tie Rod Tube Clamp
35-45	Bolt - Steering Connecting Rod Idler Lever Support to Frame
30-40	Nut - Steering Linkage (Ball Socket Stud) to Pitman Arm
30-45	Nut - Steering Connecting Rod to Tie Rod Ball Stud
30-40	Nut - Steering Connecting Rod to Idler Arm
30-45	Nut - Steering Tie Rod Ball Stud to Steering Knuckle

NOTE () Torque not a requirement, other means of control and/or specifications used, checked for alignment, bottoming, height and/or leaks.*

SPECIAL TOOLS

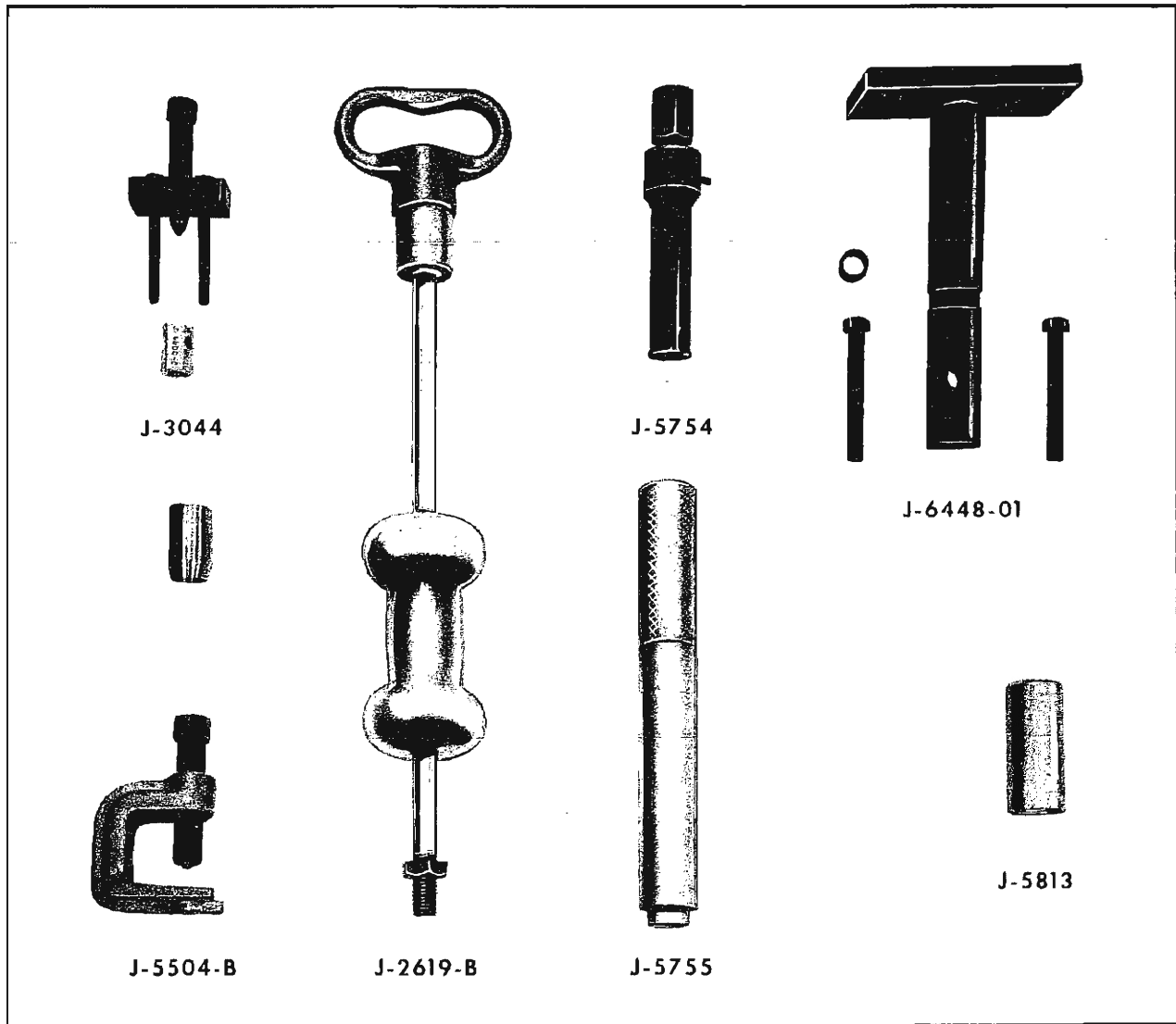

J-544-A
 J-2619-B
 J-3044
 J-5504-B
 J-5754

Tension Scale (0-4#)
 Slide Hammer
 Steering Wheel Puller
 Pitman Arm Puller
 Steering Shaft Worm Bearing Cup
 Remover (Use with J-2619-B)

J-5755
 J-5787
 J-5813
 J-6448-01
 or J-5205

Steering Shaft Worm Bearing
 Cup Remover
 Pitman Shaft Seal Protector
 Pitman Shaft Seal Installer
 Steering Gear Holding Fixture

Fig. 9-30 Standard Steering Gear - Special Tools