

CHASSIS SHEET METAL

CONTENTS OF THIS SECTION

SUBJECT	PAGE	SUBJECT	PAGE
Sheet Metal Alignment	10-1	Front Fender	10-4
Fender	10-1	Grille Panel (Upper)	10-4
Hood	10-2	Grille Panel (Lower)	10-4
Hood Hinges	10-2	Grille (Right and Left)	10-5
Hood Latch	10-2	Front Fender Cross Brace	10-5
Hood Latch Adjustment	10-2	Hood Spring	10-5
Bumper	10-4	Hood Hinge	10-5
Sheet Metal	10-4	Hood	10-6
		Radiator	10-6

SHEET METAL ALIGNMENT

Proper alignment of the front end sheet metal will provide proper relationship of adjoining sheet metal parts, ease of hood operation and eliminate squeaks, rattles and vibration.

FRONT FENDER ALIGNMENT

Vertical and fore and aft adjustment is provided at rear of fenders by enlarged holes in the fender bracket or body at the attaching points.

Fenders can be moved closer to or farther from the cowl by adding or removing shims between fender and bowl (Fig. 10-5). Fenders can also be adjusted vertically by shifting the fender on the enlarged bolt holes.

1. Check the space between the front door to fender rear edge and adjust as necessary to obtain a parallel space.

2. Check to insure that all connections at the fender attaching bolts are tight.

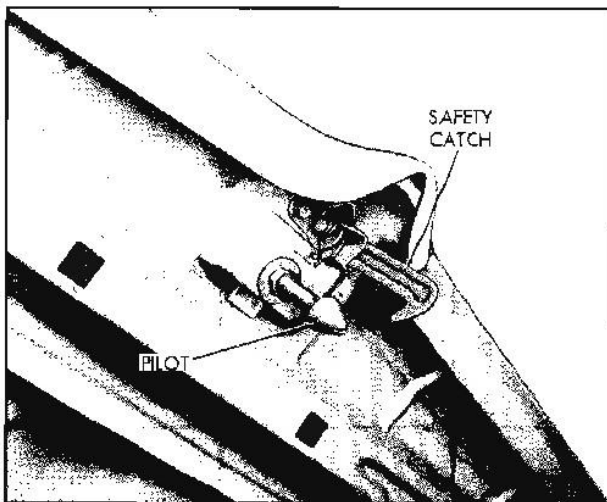

Fig. 10-1 Hood Safety Catch and Pilot

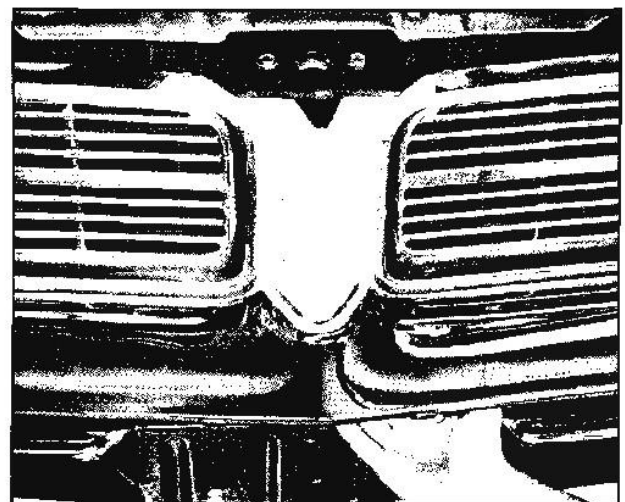

Fig. 10-2 Hood Release Latch

HOOD

The hood is of rigid sheet metal construction with the outer panel of single sheet metal with a rugged inner panel reinforcement frame. Further rigidity is given by reinforcement diagonal braces strategically located so as to give extra strength at stress points.

1. Slotted holes in the hinge bracket to hood are provided to align hood fore and aft (Fig. 10-5).

2. The parallel space between hood sides and fender is accomplished by the rubber wedges mounted to each fender.

3. The rear corners of the hood should be held down against the hood lacing to keep rear of hood from dancing or vibrating. The rear hood height is adjustable by moving hood hinge at body mount. The hinge bolt holes are enlarged giving room for adjustment.

HOOD HINGES

The hood is mounted on hinges (Fig. 10-7) mounted to wheel house. Double assist over center springs are used, (one at each hood hinge) both ends of which are fastened to the arms of the hinge. This construction provides hold-open power.

A hood to hinge reinforcement bracket which has two points of attachment is used. Fore and aft adjustment of the hood is provided for by slotted holes in the bracket.

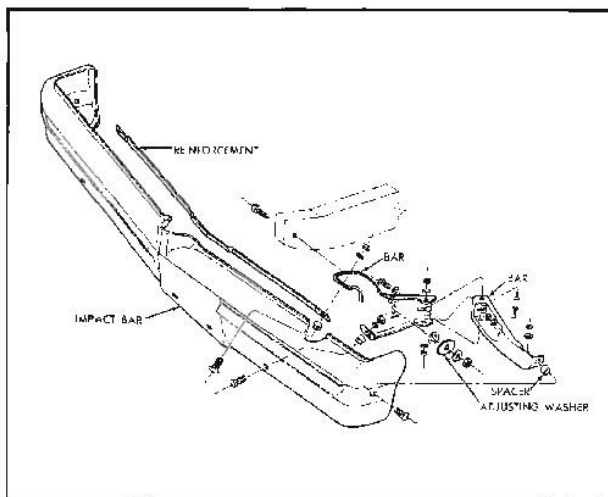

Fig. 10-3 Front Bumper

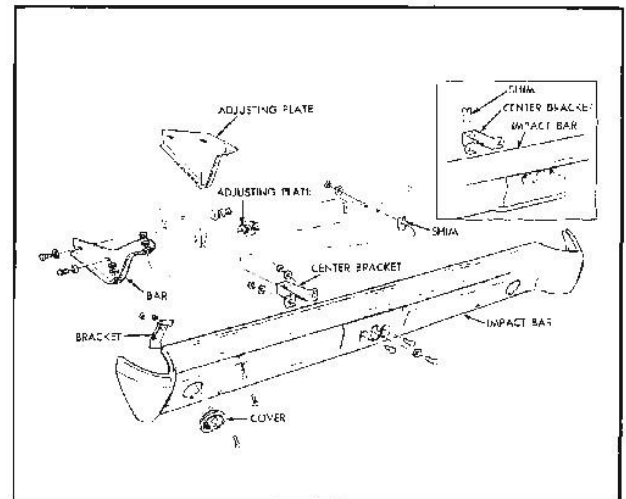

Fig. 10-4 Rear Bumper

HOOD LATCH

A positive locking hood latch is used and incorporates a safety hood latch and a pilot assembly (Fig. 10-1). The hood latch is fastened to the hood and both assemblies lock to the front fender cross brace when hood is closed. The hood is opened by reaching below the center of the front bumper and pushing release rod toward right front fender (Fig. 10-2). To release the safety latch, reach under partially opened hood and push release lever upward (Fig. 10-2).

HOOD LATCH ADJUSTMENT

Should the hood be difficult or even fail to release or close, there are 2 adjustments that can be made.

1. To adjust the hood latch fore and aft, shim front screw position.

2. To adjust hood latch, sideways loosen three attaching screws and align latch left or right.

Proper adjustment of hood latch to provide for easy hood closing is as follows:

1. Check tightness of hood latch bolts.

2. Raise or lower hood bumpers on front fender cross brace (Fig. 10-5).

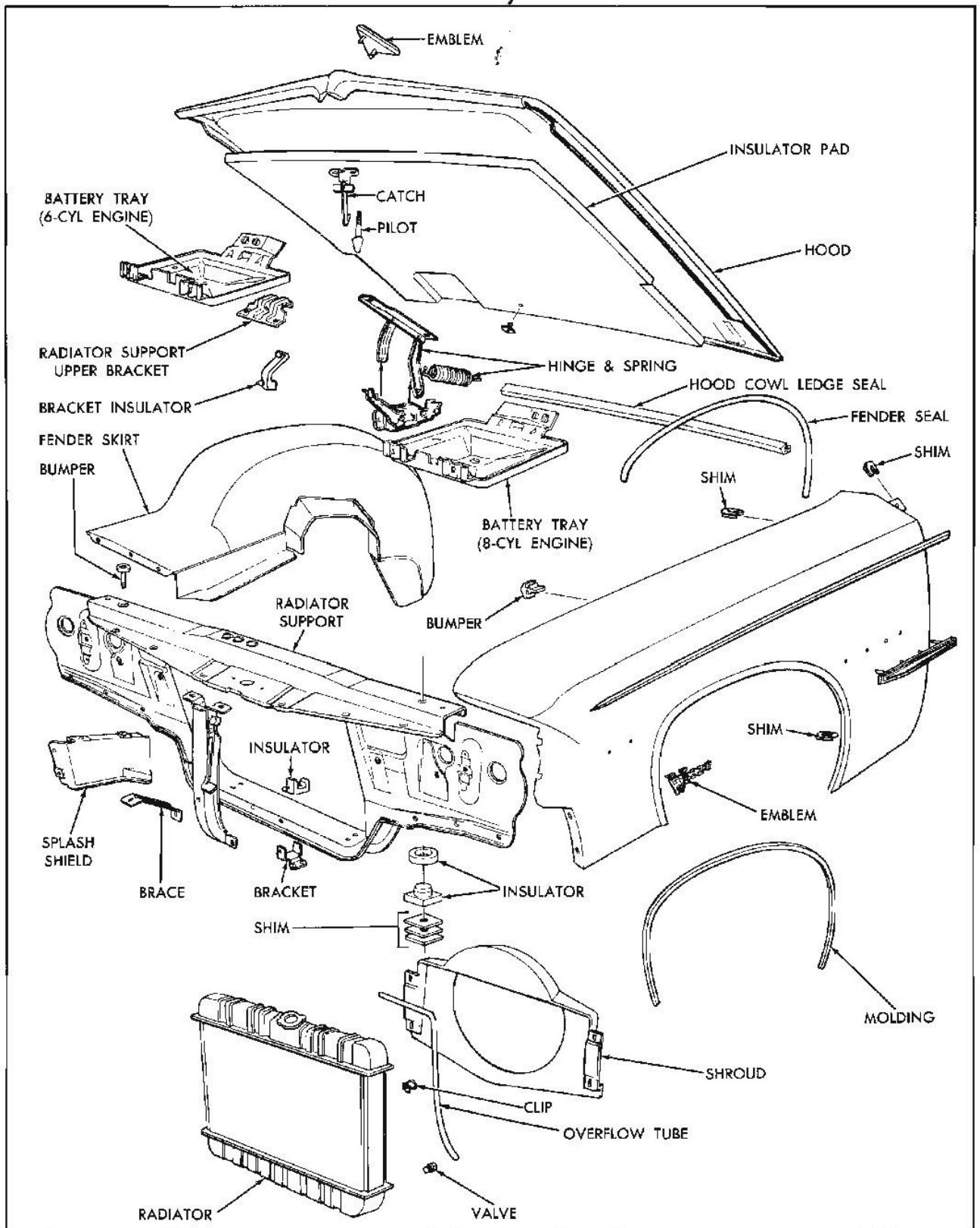

Fig. 10-5 Exploded View—Front End Sheet Metal

3. Press down on nose of hood.

a. If some give or looseness is noticed, hood is not tight and will vibrate and raise up on corners at high speeds. In this case, shorten latch bolt and recheck.

b. If hood is tight with no give, the hood could be properly adjusted or could be too tight.

CHECK AS FOLLOWS:

1. Close hood.
2. Release latch and raise hood 10"-12".
3. Manually close hood with sufficient effort to insure hood tightness.
4. Adjust hood latch assembly and bumpers to permit hood to close flush with fenders and upper grille panel.

BUMPER ALIGNMENT

FRONT AND REAR

The bumper mounting bracket is the only adjusting point for the front or rear bumper. This adjusting point is used for both fore and aft and vertical adjustments.

SHEET METAL REPLACEMENT

FRONT FENDER—REMOVE AND REPLACE

REMOVE

1. Remove front bumper.
2. Remove fender extension.
3. Remove head lamps and head lamp frame.
4. Remove three screws—fender to lower grille panel.
5. Remove two screws—front fender to front fender cross brace.
6. Remove nine screws—fender to body (upper).

7. Remove one screw—fender to rear upper shroud and one screw—fender to rear lower shroud.

8. Remove fender by lifting up and away.

NOTE: For right front fender removal, disconnect radiator and antenna mast, remove antenna nut, remove screw from fender rear brace to antenna and let assembly drop through fender.

REPLACE

To install fender, reverse the above procedure.

GRILLE PANEL (UPPER)—REMOVE AND REPLACE

1. Remove head lamp doors, head lamp and fender extensions.
2. Remove seven upper screws—grille panel to front fender cross brace.
3. Remove ten lower screws—lower to upper grille panel.
4. Lift panel and pull forward.
5. To replace upper grille panel, reverse above procedure.

GRILLE PANEL (LOWER)—REMOVE AND REPLACE

1. Remove bumper.
2. Remove three screws each side—front fender to lower grille panel.
3. Remove one screw each side—fender extension to lower panel.
4. Remove ten screws—lower panel to upper panel.
5. Remove 6 screws, lower panel to lower radiator right and left hand baffle assemblies.
6. Remove lower grille panel forward and down.
7. To replace lower grille panel, reverse the above procedure.

**GRILLE (RIGHT AND LEFT)—
REMOVE AND REPLACE**

1. Remove upper grille panel assembly.
2. Unscrew and remove grille from upper grille panel assembly.
3. To install right or left grille, reverse the above procedure.

**FRONT FENDER CROSS BRACE
REMOVE AND REPLACE**

1. Remove upper grille panel.
2. Remove two supports.
3. Remove battery.
4. Remove three screws each side—baffle assembly to front fender cross brace and two screws each side cross brace to fender.
5. Slide cross brace forward and remove.

6. To install front fender cross brace, reverse the above procedure.

HOOD HINGE SPRING—REPLACE

Hood hinge springs can be removed by propping hood open, and pulling front of spring off of hinge. When replacing the spring, hook the rear end of pin first, then stretch the spring out and hook it at front.

HOOD HINGE—REMOVE AND REPLACE

1. Open hood.
2. While one man holds hood, remove spring, hinge to fender and cowl attaching screws, hinge to hood attaching nuts, and remove hinge.
3. Position new hinge to fender, install and tighten attaching screws.
4. Position hinge to hood and install flat washers, lock nuts and tighten just snug.

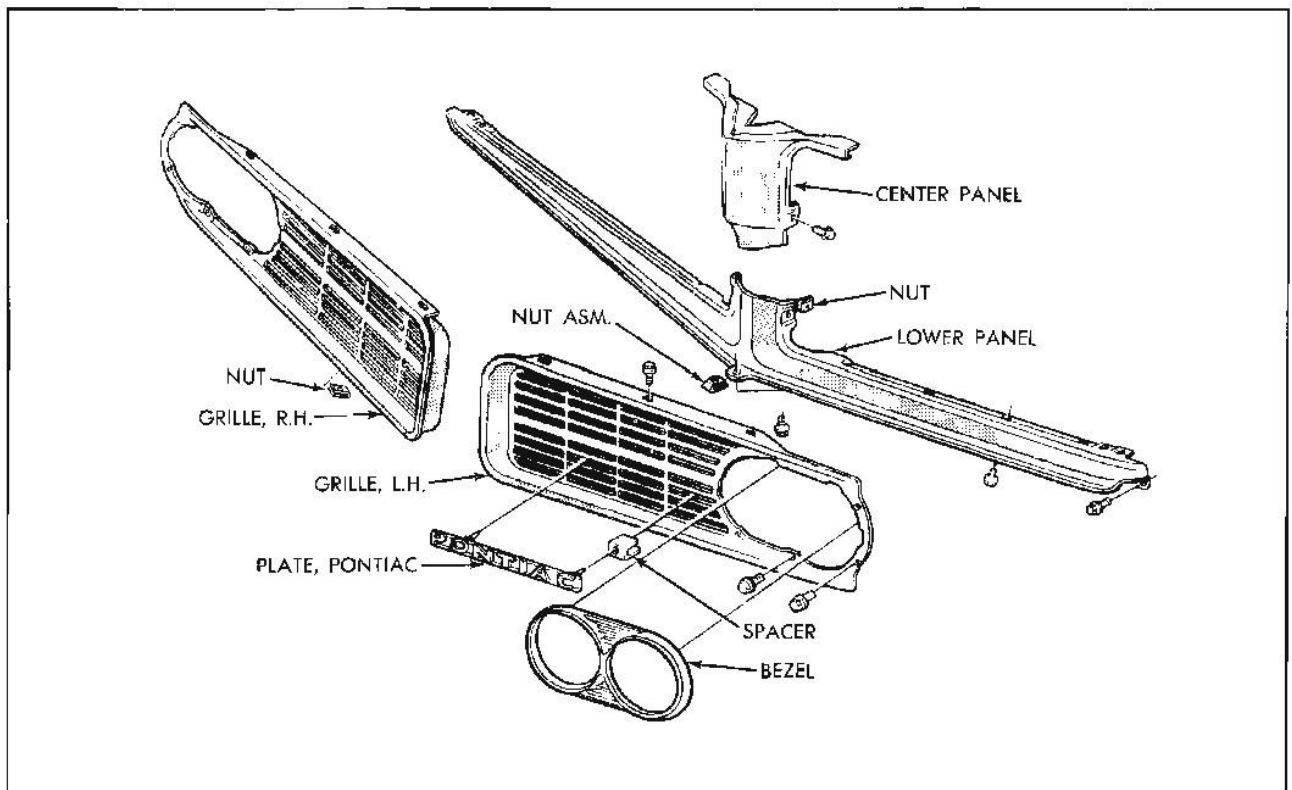

Fig. 10-6 Grille Details

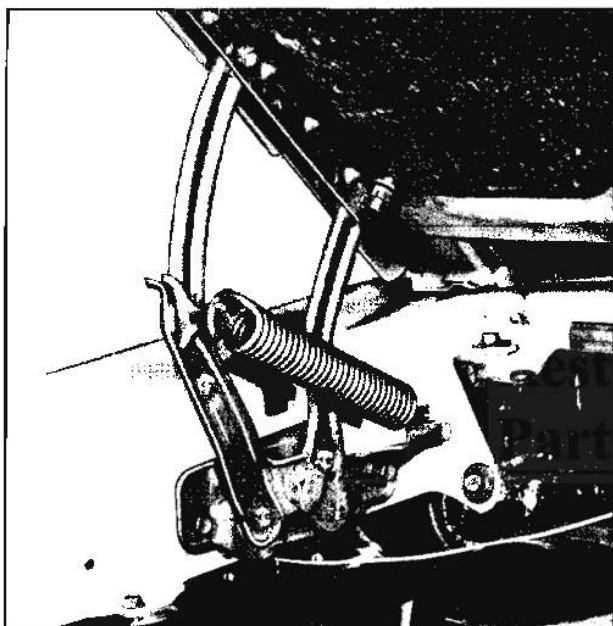

Fig. 10-7 Hood Hinge

5. Replace spring.
6. Close hood and check hood alignment.
7. If hood is misaligned, measure amount of misalignment.
 - a. Open hood, mark position of hinge relative to hood.

- b. Loosen hinge at hood and move hinge the amount it was off.

- c. Tighten securely and recheck alignment.

HOOD—REPLACE

The hood can be removed very quickly by disconnecting it from the hinges at the hood reinforcement.

When replacing the hood, adjust the alignment, one hinge at a time, as outlined in steps 6 and 7 under HOOD HINGE—REMOVE AND REPLACE.

RADIATOR—REMOVE AND REPLACE

1. Drain radiator.
2. Disconnect overflow, upper and lower radiator hoses.
3. Remove radiator fan shield.
4. Remove radiator.
5. To install radiator, reverse above procedure.