

1967

PONTIAC MOTOR DIVISION

PONTIAC
Underground
Certified Badass



PONTIAC

TEMPEST

FIREBIRD

MOLDING
and
CLIP
CATALOG

PARTS AND ACCESSORIES

EFFECTIVE

APRIL

FIRST

1967

1967 MOLDING AND ATTACHING PARTS

This publication is issued for the model year of 1967. It is prepared to provide a fast and accurate method for locating part numbers for all exterior moldings and their attaching parts. To insure all information is current and up to date, consult the MASTER PARTS CATALOG and PRICE SCHEDULE. Any suggestions or discrepancies that you may find in this booklet should be forwarded to this department.

The body illustrations are keyed to the moldings and like numbers are to be found in the text. In the event no attaching parts are shown, the molding is of a snap-on type.

See illustration below for interpretation of nomenclature.

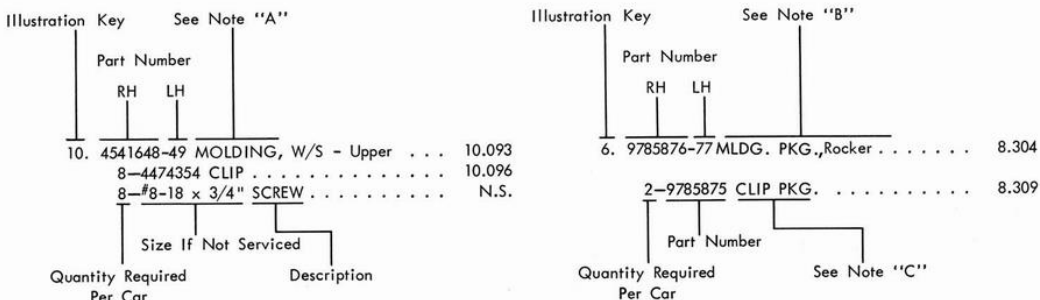

Note "A"—Molding only, requires all listed attaching parts for installation.
 Note "B"—Molding Packages contain the molding and all attaching parts for one side only.
 Note "C"—Clip Package is not required when Molding Package is used.

INDEX

Page	Model	Body Style	Option Shown	Page	Model	Body Style	Option Shown
1	2337	Firebird H.T. Cpe.	O.H.C.-6 Eng.; Rally Stripes & Cordova Top	27	3335-3535	Tempest Rear End	-
2	2367	Firebird Conv. Cpe.	O.H.C.-6-Sprint Eng.	28	3935	Safari Rear End	-
3	2337	Firebird H.T. Cpe.	326 Eng.	28	3739	Le Mans Rear End	-
4	2367	Firebird Conv. Cpe.	326 H.O. Eng. & "H.O." Stripes	29	4267	G.T.O. Rear End	-
5	2337	Firebird H.T. Cpe.	400 Eng. & 2-T/Paint	29	3569	Tempest Rear End	-
6	2367	Firebird Conv. Cpe.	400 Eng. & Rally Stripes	30	5211	Catalina 2-Dr. Spt. Sed.	428 Eng. 2-T/Paint & Skirts
7	2337	Firebird Front End	O.H.C.-6 & 326 Eng.	31	5235-45	Catalina Sta. Wag.	Cordova Top
7	2367	Firebird Front End	400 Sport Option	32	5239	Catalina 4-Dr. H.T.	Ventura Option
8	2337	Firebird Rear End	O.H.C.-6 & 326, Eng. & Cordova Top	33	5267	Catalina Conv. Cpe.	2+2 Option & Skirts
8	2367	Firebird Rear End	400 Sport Option	34	5269	Catalina 4-Dr. Sed.	Std.
9	3307	Tempest 2-Dr. Cpe.	O.H.C.-6 Eng. & 2-T/Paint	35	5287	Catalina 2-Dr. Spt. Cpe.	428 Eng. & Cordova Top
10	3335	Tempest Sta. Wag.	326 Eng. & 2-T/Paint	36	5635-45	Exec. Sta. Wag.	Std.
11	3369	Tempest 4-Dr. Sed.	O.H.C.-6-Sprint Eng.	37	5639	Exec. 4-Dr. H.T.	428 Eng. & Cordova Top
12	3507	Custom 2-Dr. Cpe.	O.H.C.-6-Sprint Eng. & Stripes	38	5669	Exec. 4-Dr. Sed.	2-T/Paint
13	3517	Custom 2-Dr. Spt. Cpe.	O.H.C.-6 Eng. & Cordova Top	39	5687	Exec. 2-Dr. Spt. Cpe.	Skirts
14	3535	Custom Sta. Wag.	O.H.C.-6 Eng.	40	6239	B'ville 4-Dr. H.T.	Brougham
15	3539	Custom 4-Dr. H.T.	326 Eng.	41	6245	B'ville Sta. Wag.	Std.
16	3567	Custom Conv. Cpe.	O.H.C.-6 Eng.	42	6267	B'ville Conv. Cpe.	428 Eng.
17	3569	Custom 4-Dr. Sed.	O.H.C.-6 Eng. & 2-T/Paint	43	6287	B'ville 2-Dr. Spt. Cpe.	Std.
18	3707	Le Mans 2-Dr. Cpe.	326 Eng.	44	6657	Grand Prix Spt. Cpe.	Cordova Top & Skirts
19	3717	Le Mans 2-Dr. Spt. Cpe.	O.H.C.-6-Sprint & Stripes	45	6667	Grand Prix Conv. Cpe.	428 Eng. & Skirts
20	3739	Le Mans 4-Dr. H.T.	326 Eng. & Cordova Top	46	11-35-45-		
21	3767	Le Mans Conv. Cpe.	O.H.C.-6-Sprint Eng. & Stripes	69		Cat./Exec./2+2 Frt. End.	-
22	3935	Safari Sta. Wag.	O.H.C.-6 Eng.	46	39-67-87	B'ville Front End	-
23	4207	G.T.O. 2-Dr. Cpe.	Std.	47	6667	Grand Prix Frt. End	-
24	4217	G.T.O. 2-Dr. Spt. Cpe.	Cordova Top	47	5211-69	Catalina Rear End	-
25	4267	G.T.O. Conv. Cpe.	Std.	48	5235-45	Catalina Rear End	2-T/Paint
26	35-39-69	Tempest Front End	-	48	5635-45	Exec. Rear End	-
26	07-17-67	G.T.O. Front End	-	49	6245	B'ville Rear End	Cordova Top
27	07-17	Tempest Rear End	Cordova Top	49	5639	Exec. Rear End	-
				50	6267	B'ville Rear End	-
				50	5287	Catalina Rear End	2+2 Option & Cordova Top
				51	6657	Grand Prix Rear End	Cordova Top
				52		Clip Packages and Contents	
				53		Clip Packages and Contents	

PONTIAC MOTOR DIVISION
 PARTS AND ACCESSORIES DEPARTMENT
 196 OAKLAND AVE.
 PONTIAC, MICHIGAN
 48053

Decor, ornamentation and trim shown within this book does not necessarily represent a specific option on any particular model. See the MASTER PARTS CATALOG for model identification.

Information herein is up-to-date as of the date of publication. Dealerships should make necessary revisions when the monthly parts release and change notice or any other Parts or Service Department bulletin is received.

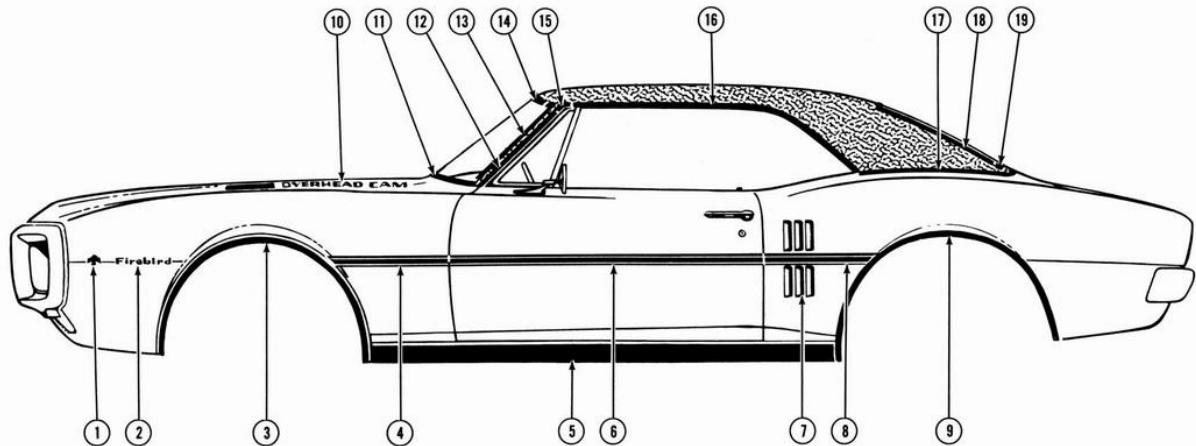

1967 FIREBIRD HARDTOP COUPE—2337 (O.H.C.-6 ENGINE, W/CORDOVA TOP & RALLY STRIPES)

Key Qty.	Part No.	Name	Group No.	Key Qty.	Part No.	Name	Group No.
1.	2-9789589	EMBLEM	8.147	10.	(Cont'd.)		
	4-9420621	NUT	8.148		9789396-97	EMBLEM, Mariner Turquoise . . .	8.030
2.	2-9789532	PLATE, "Firebird"	8.147		9789398-99	EMBLEM, Plum Mist	8.030
	6-9420621	NUT	8.148		9789400-01	EMBLEM, Burgundy	8.030
3.	9785880-81	MLDG. PKG., W/Opening . . .	8.147		9789402-03	EMBLEM, Silver Glaze	8.030
	14-588546	SCREW	8.148		9789404-05	EMBLEM, Regimental Red	8.030
4.	9789312-13	STRIPE, Black	8.147		9789406-07	EMBLEM, Champagne	8.030
	9789314-15	STRIPE, White	8.147		9789408-09	EMBLEM, Montego Cream	8.030
	9789316-17	STRIPE, Red	8.147		8-9420185	NUT	8.921
5.	9785876-77	MLDG. PKG., Rocker	8.304	11.	7639926-27	MOLDING, W/S - Lower	10.093
	2-9785875	CLIP PKG.	8.309		8-7663148	CLIP	10.096
6.	2-9789303	STRIPE, Black.	12.112		8-#8-18 x 1/2"	SCREW	N.S.
	2-9789304	STRIPE, White	12.112		2-7689573	SPACER.	10.096
	2-9789305	STRIPE, Red	12.112	12.	7656810-11	SCALP, Pillar Drip	12.075
7.	12-4229829	MLDG. PKG., Louver	12.116	13.	7639558-59	MOLDING, W/S - Side.	10.093
	24-4528486	NUT.	12.118		6-7639528	CLIP	10.096
8.	9789306-07	STRIPE, Black	12.116	14.	7638868	MOLDING, W/S - Upper.	10.093
	9789308-09	STRIPE, White	12.116		7-7639528	CLIP	10.096
	9789310-11	STRIPE, Red	12.116	15.	7661072-73	ESCUTCHEON, Scalp	12.075
9.	4229493-94	MLDG. PKG., W/Opening . . .	12.116	16.	7639406-07	SCALP, Roof	12.075
	16-588546	SCREW	12.118	17.	3914078-77	MLDG. PKG., Belt	12.116
10.	9785946-47	EMBLEM, Verdoro Green	8.030		11-7731589	CLIP.	12.118
	9785948-49	EMBLEM, Coronado Gold	8.030		4-7669079	CLIP.	12.118
	9785950-51	EMBLEM, Mayfair Maize	8.030		4-9419764	NUT.	12.118
	9789380-81	EMBLEM, Starlight Black	8.030	18.	7639864-65	MOLDING, B/Wind. - Side	11.208
	9789382-83	EMBLEM, Cameo Ivory	8.030		4-7639528	CLIP.	11.209
	9789384-85	EMBLEM, Montreux Blue	8.030		2-7693140	CLIP.	11.209
	9789386-87	EMBLEM, Fathom Blue	8.030	19.	7639866-67	MOLDING, B/Wind. - Lower	11.208
	9789388-89	EMBLEM, Tyrol Blue	8.030		8-7639528	CLIP.	11.209
	9789390-91	EMBLEM, Signet Gold	8.030				
	9789392-93	EMBLEM, Linden Green	8.030				
	9789394-95	EMBLEM, Gulf Turquoise	8.030				

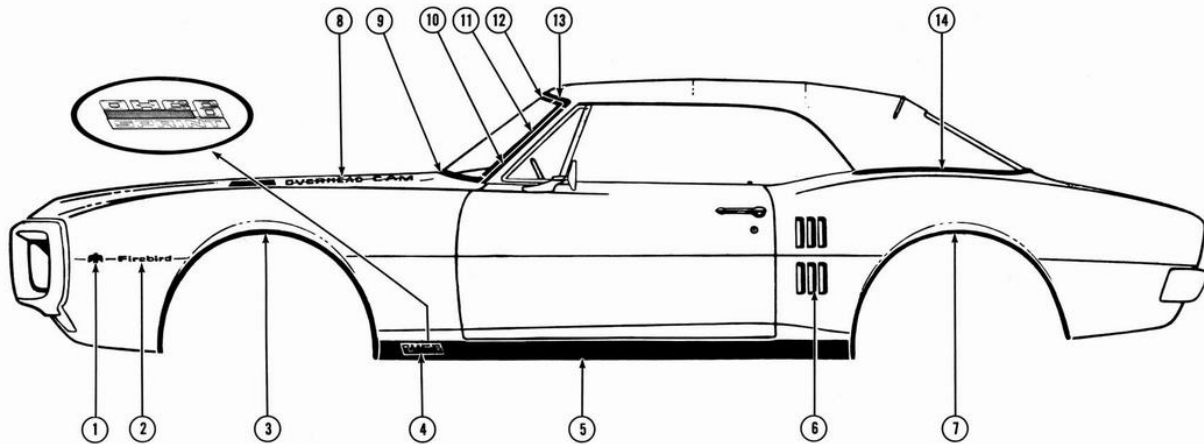

1967 FIREBIRD CONVERTIBLE COUPE—2367 (O.H.C.-6-SPRINT ENGINE)

Key Qty.	Part No.	Name	Group No.	Key Qty.	Part No.	Name	Group No.
1.	2-9789589	EMBLEM	8.147	8.	(Cont'd.)		
	4-9420621	NUT	8.148		9789398-99	EMBLEM, Plum Mist	8.030
2.	2-9789532	PLATE, "Firebird"	8.147		9789400-01	EMBLEM, Burgundy	8.030
	6-9420621	NUT	8.148		9789402-03	EMBLEM, Silver Glaze	8.030
3.	9785880-81	MLDG. PKG., W/Opening	8.147		9789404-05	EMBLEM, Regimental Red	8.030
	14-588546	SCREW	8.148		9789406-07	EMBLEM, Champagne	8.030
4.	9788227-28	EMBLEM, "O.H.C.-6-Sprint"	8.304		9789408-09	EMBLEM, Montego Cream	8.030
	4-9420621	NUT	8.309		8-9420185	NUT	8.921
5.	9785878-79	MLDG. PKG., Rocker	8.304	9.	7648736-37	MOLDING, W/S - Lower	10.093
	2-9785875	CLIP PKG.	8.309		8-7663148	CLIP	10.096
6.	12-4229829	MLDG. PKG., Louver	12.116		8-#8-18 x 1/2"	SCREW	N.S.
	24-4528486	NUT	12.118		2-7689573	SPACER	10.096
7.	4229493-94	MLDG. PKG., W/Opening	12.116	10.	7648738-39	MOLDING, Pillar Finish	10.093
	16-588546	SCREW	12.118		4-#8-18 x 1/2"	SCREW	N.S.
8.	9785946-47	EMBLEM, Verdoro Green	8.030	11.	7639560-61	MOLDING, W/S - Side	10.093
	9785948-49	EMBLEM, Coronado Gold	8.030		6-4474354	CLIP	10.096
	9785950-51	EMBLEM, Mayfair Maize	8.030	12.	7638870	MOLDING, W/S - Upper	10.093
	9789380-81	EMBLEM, Starlight Black	8.030		7-4474354	CLIP	10.096
	9789382-83	EMBLEM, Cameo Ivory	8.030	13.	7639786-87	HEADER	10.093
	9789384-85	EMBLEM, Montreux Blue	8.030		5-4409925	SCREW	10.096
	9789386-87	EMBLEM, Fathom Blue	8.030		2-#8-18 x 3/8"	SCREW	N.S.
	9789388-89	EMBLEM, Tyrol Blue	8.030	14.	3914092-91	MLDG. PKG., Pinch weld	12.116
	9789390-91	EMBLEM, Signet Gold	8.030		12-7672609	CLIP	12.118
	9789392-93	EMBLEM, Linden Green	8.030		7-#8-18 x 1/2"	SCREW	N.S.
	9789394-95	EMBLEM, Gulf Turquoise	8.030				
	9789396-97	EMBLEM, Mariner Turquoise	8.030				

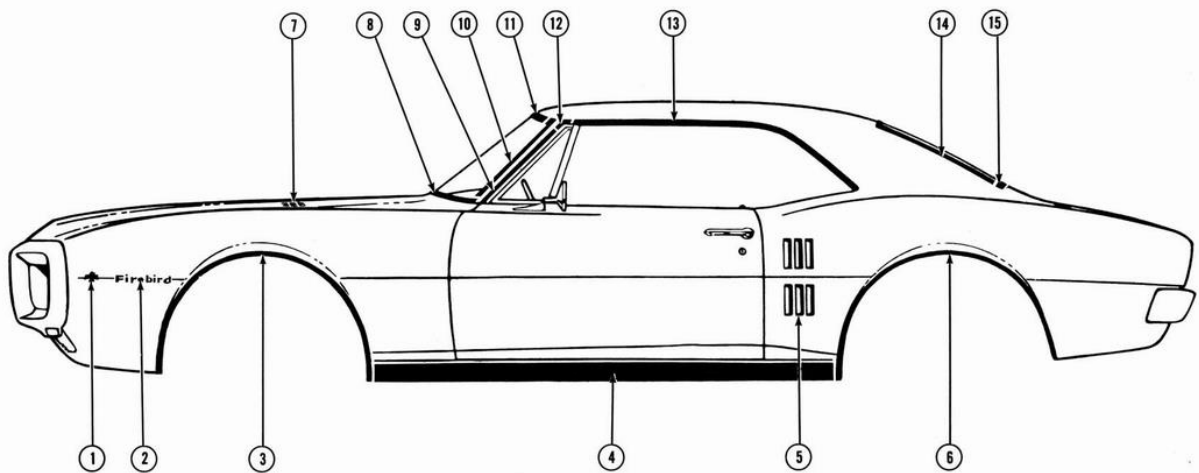

1967 FIREBIRD HARDTOP COUPE-2337 (326 ENGINE)

Key Qty.	Part No.	Name	Group No.	Key Qty.	Part No.	Name	Group No.
1.	2-9789589	EMBLEM	8.147	8.	7639926-27	MOLDING, W/S - Lower	10.093
	4-9420621	NUT	8.148		8-7663148	CLIP	10.096
					8-#8-18 x 1/2"	SCREW	N.S.
					2-7689573	SPACER	10.096
2.	2-9789532	PLATE, "Firebird"	8.147	9.	7656810-11	SCALP, Pillar Drip	12.075
	6-9420621	NUT	8.148	10.	7639558-59	MOLDING, W/S - Side	10.093
3.	9785880-81	MLDG. PKG., W/Opening	8.147		6-7639140	CLIP	10.096
	14-588546	SCREW	8.148	11.	7638868	MOLDING, W/S - Upper	10.093
4.	9785876-77	MLDG. PKG., Rocker	8.304		7-7639140	CLIP	10.096
	2-9785875	CLIP PKG.	8.309	12.	7661072-73	ESCUTCHEON, Scalp	12.075
5.	12-4229829	MLDG. PKG., Louver	12.116	13.	7639406-07	SCALP, Roof	12.075
	24-4528486	NUT	12.118	14.	7639864-65	MOLDING, B/Wind. - Side.	11.208
6.	4229493-94	MLDG. PKG., W/Opening	12.116		6-7693140	CLIP	11.209
	16-588546	SCREW	12.118	15.	7639866-67	MOLDING, B/Wind. - Lower.	11.208
7.	9777847-48	EMBLEM, "326".	8.030		8-7639140	CLIP	11.209
	4-9420185	NUT	8.921				

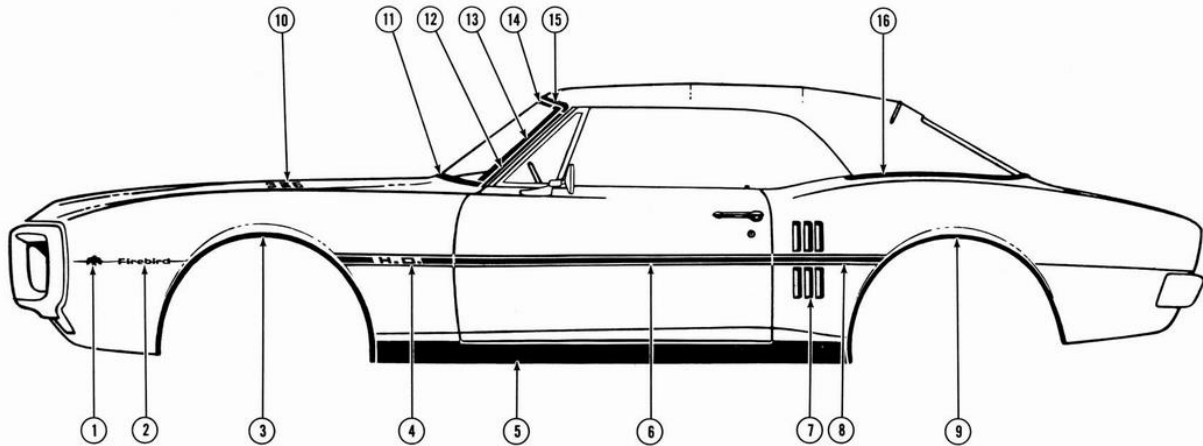

1967 FIREBIRD CONVERTIBLE COUPE—2367 (326 H.O. ENGINE & H.O. STRIPES)

Key Qty.	Part No.	Name	Group No.	Key Qty.	Part No.	Name	Group No.
1.	2-9789589	EMBLEM	8.147	9.	4229493-94	MLDG. PKG., W/Opening	12.116
	4-9420621	NUT	8.148		16-588546	SCREW	12.118
2.	2-9789532	PLATE, "Firebird"	8.147	10.	9777847-48	EMBLEM, "326"	8.030
	6-9420621	NUT	8.148		4-9420185	NUT	8.921
3.	9785880-81	MLDG. PKG., W/Opening	8.147	11.	7648736-37	MOLDING, W/S - Lower	10.093
	14-588546	SCREW	8.148		8-7663148	CLIP	10.096
4.	9789825-26	STRIPES, H.O. - Black	8.147		8-#8-18 x 1/2"	SCREW	N.S.
	9789827-28	STRIPES, H.O. - White	8.147		2-7689573	SPACER.	10.096
	9789829-30	STRIPES, H.O. - Red	8.147	12.	7648738-39	MOLDING, Pillar Finish	10.093
5.	9785876-77	MLDG. PKG., Rocker	8.304		4-#8-18 x 1/2"	SCREW	N.S.
	2-9785875	CLIP PKG.	8.309	13.	7639560-61	MOLDING, W/S - Side	10.093
6.	2-9789303	STRIPE, Black	12.112		6-4474354	CLIP	10.096
	2-9789304	STRIPE, White	12.112	14.	7638870	MOLDING, W/S - Upper	10.093
	2-9789305	STRIPE, Red.	12.112		7-4474354	CLIP	10.096
7.	12-4229829	MLDG. PKG., Louver	12.116	15.	7639786-87	HEADER	10.093
	24-4528486	NUT	12.118		5-4409925	SCREW	10.096
8.	9789306-07	STRIPE, Black	12.116		2-#8-18 x 3/8"	SCREW	N.S.
	9789308-09	STRIPE, White	12.116	16.	3914092-91	MLDG. PKG., Pinch weld	12.116
	9789310-11	STRIPE, Red	12.116		12-7672609	CLIP.	12.118
					7-#8-18 x 1/2"	SCREW.	N.S.

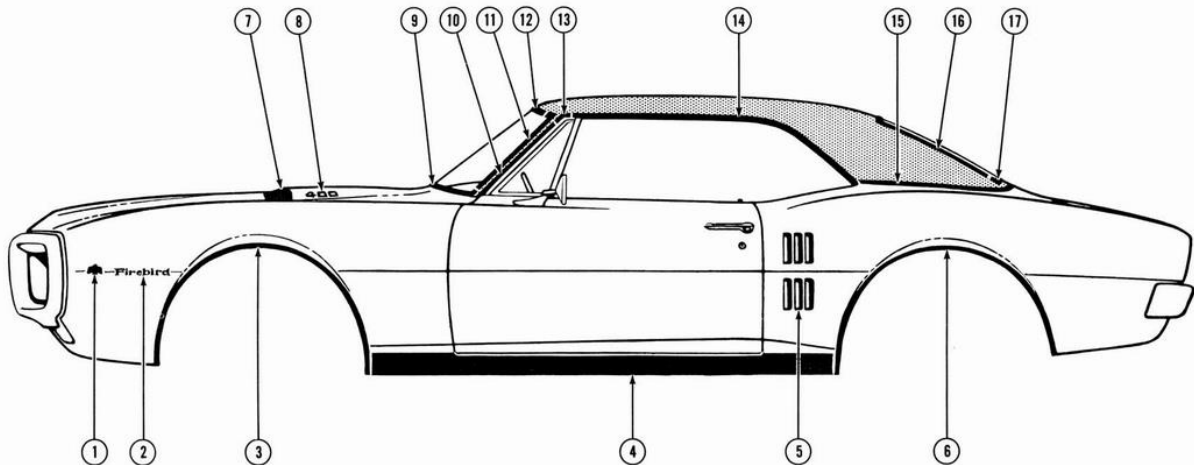

1967 FIREBIRD HARDTOP COUPE—2337 (400 ENGINE & 2-TONE PAINT)

Key Qty.	Part No.	Name	Group No.	Key Qty.	Part No.	Name	Group No.
1.	2-9789589	EMBLEM	8.147	9.	7639926-27	MOLDING, W/S - Lower	10.093
	4-9420621	NUT	8.148		8-7663148	CLIP	10.096
					8-#8-18 x 1/2"	SCREW	N.S.
					2-7689573	SPACER.	10.096
2.	2-9789532	PLATE, "Firebird"	8.147	10.	7656810-11	SCALP, Pillar Drip	12.075
	6-9420621	NUT	8.148	11.	7639558-59	MOLDING, W/S - Side.	10.093
3.	9785880-81	MLDG. PKG., W/Opening	8.147		6-7639140	CLIP	10.096
	14-588546	SCREW	8.148	12.	7638868	MOLDING, W/S - Upper	10.093
4.	9785876-77	MLDG. PKG., Rocker	8.304		7-7639140	CLIP	10.096
	2-9785875	CLIP PKG.	8.309	13.	7661072-73	ESCUTCHEON, Scalp	12.075
5.	12-4229829	MLDG. PKG., Louver	12.116	14.	7639406-07	SCALP, Roof	12.075
	24-4528486	NUT	12.118	15.	3914078-77	MLDG. PKG., Belt	12.116
6.	4229493-94	MLDG. PKG., W/Opening	12.116		11-7731589	CLIP.	12.118
	16-588546	SCREW	12.118		4-7669079	CLIP.	12.118
					4-9419764	NUT.	12.118
7.	9777957-58	ORNAMENT, Side	8.030	16.	7639864-65	MOLDING, B/Wind. - Side	11.208
	4-9420621	NUT	8.148		6-7693140	CLIP	11.209
8.	9789482-83	EMBLEM, "400".	8.030	17.	7639866-67	MOLDING, B/Wind. - Lower	11.208
	4-9420185	NUT	8.921		8-7639140	CLIP	11.209

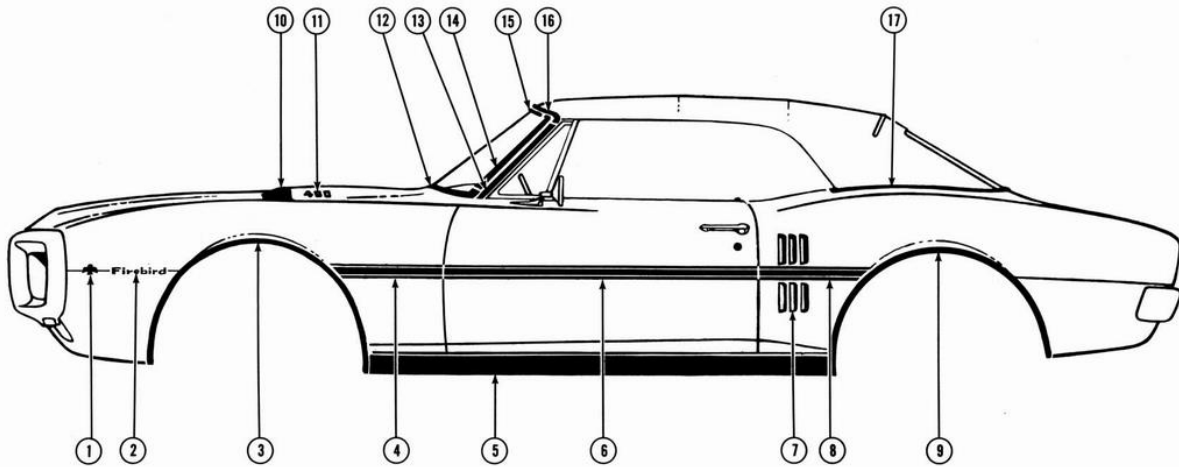

1967 FIREBIRD CONVERTIBLE COUPE—2367 (400 ENGINE & RALLY STRIPES)

Key Qty.	Part No.	Name	Group No.	Key Qty.	Part No.	Name	Group No.
1.	2-9789589 EMBLEM		8.147	10.	9777957-58 ORNAMENT, Side		8.030
	4-9420621 NUT		8.148		4-9420621 NUT		8.148
2.	2-9789532 PLATE, "Firebird"		8.147	11.	9789482-83 EMBLEM, "400"		8.030
	6-9420621 NUT		8.148		4-9420185 NUT		8.921
3.	9785880-81 MLDG. PKG., W/Opening		8.147	12.	7648736-37 MOLDING, W/S - Lower		10.093
	14-588546 SCREW		8.148		8-7663148 CLIP		10.096
					8-#8-18 x 1/2" SCREW		N.S.
4.	9789312-13 STRIPE, Black		8.147		2-7689573 SPACER		10.096
	9789314-15 STRIPE, White		8.147	13.	7648738-39 MOLDING, Pillar - Finish		10.093
	9789316-17 STRIPE, Red		8.147		4-#8-18 x 1/2" SCREW		N.S.
5.	9785876-77 MLDG. PKG., Rocker		8.304	14.	7639560-61 MOLDING, W/S - Side		10.093
	2-9785875 CLIP PKG.		8.309		6-4474354 CLIP		10.096
6.	2-9789303 STRIPE, Black		12.112	15.	7638870 MOLDING, W/S - Upper		10.093
	2-9789304 STRIPE, White		12.112		7-4474354 CLIP		10.096
	2-9789305 STRIPE, Red		12.112	16.	7639786-87 HEADER		10.093
7.	12-4229829 MLDG. PKG., Louver		12.116		5-4409925 SCREW		10.096
	24-4528486 NUT.		12.118		2-#8-18 x 3/8" SCREW		N.S.
8.	9789306-07 STRIPE, Black		12.116	17.	3914092-91 MLDG. PKG., Pinch weld		12.116
	9789308-09 STRIPE, White		12.116		12-7672609 CLIP.		12.118
	9789310-11 STRIPE, Red		12.116		7-#8-18 x 1/2" SCREW		N.S.
9.	4229493-94 MLDG. PKG., W/Opening		12.116				
	16-588546 SCREW		12.118				

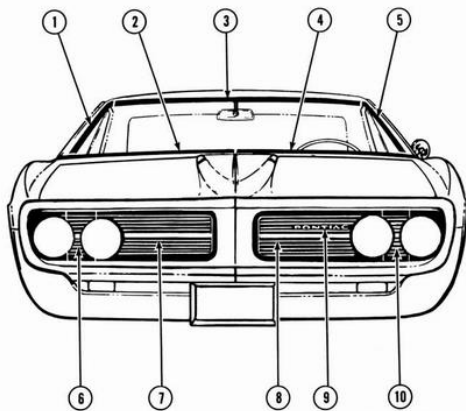

**1967 FIREBIRD HARDTOP COUPE—
FRONT END VIEW—2337
(EXC. 400 SPORT OPTION)**

Key	Qty.	Part No.	Name	Group No.
1.	7639558	MOLDING, W/S - Side	10.093	
	3-	7639140 CLIP	10.096	
2.	7639926	MOLDING, W/S - Lower	10.093	
	4-	7663148 CLIP	10.096	
	4-	#8-18 x 1/2" SCREW	N.S.	
	1-	7689573 SPACER	10.096	
3.	7638868	MOLDING, W/S - Upper	10.093	
	7-	7639140 CLIP	10.096	
4.	7639927	MOLDING, W/S - Lower	10.093	
	4-	7663148 CLIP	10.096	
	4-	#8-18 x 1/2" SCREW	N.S.	
	1-	7689573 SPACER	10.096	
5.	7639559	MOLDING, W/S - Side	10.093	
	3-	7639140 CLIP	10.096	
6.	9788858	ESCUTCHEON, Grille	1.268	
	2-	9790767 SCREW	1.269	
7.	9788856	GRILLE, R.H.	1.266	
8.	9788857	GRILLE, L.H.	1.266	
9.	9788859	PLATE, "Pontiac"	1.303	
	2-	9789188 BRACKET	1.303	
	2-	9785896 RETAINER	1.303	
10.	9788858	ESCUTCHEON, Grille	1.268	
	2-	9790767 SCREW	1.269	

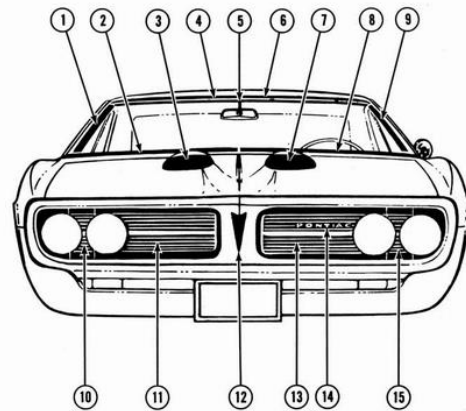

**1967 FIREBIRD CONVERTIBLE COUPE—
FRONT END VIEW—2367
(WITH 400 SPORT OPTION)**

Key	Qty.	Part No.	Name	Group No.
1.	7639560	MOLDING, W/S - Side	10.093	
	3-	7639140 CLIP	10.096	
2.	7648736	MOLDING, W/S - Lower	10.093	
	4-	7663148 CLIP	10.096	
	4-	#8-18 x 1/2" SCREW	N.S.	
	1-	7689573 SPACER	10.096	
3.	9777957	ORNAMENT - Side	8.030	
	2-	9420621 NUT	8.148	
4.	7639786	HEADER, R.H.	10.093	
	3-	4409925 SCREW	10.096	
	1-	#8-18 x 3/8" SCREW	N.S.	
5.	7638870	MOLDING, W/S - Upper	10.093	
	7-	4474354 CLIP	10.096	
6.	7639787	HEADER, L.H.	10.093	
	3-	4409925 SCREW	10.096	
	1-	#8-18 x 3/8" SCREW	N.S.	
7.	9777958	ORNAMENT - Side	8.030	
	2-	9420621 NUT	8.148	
8.	7648737	MOLDING, W/S - Lower	10.093	
	4-	7663148 CLIP	10.096	
	4-	#8-18 x 1/2" SCREW	N.S.	
	1-	7689573 SPACER	10.096	
9.	7639561	MOLDING, W/S - Side	10.093	
	3-	4474354 CLIP	10.096	
10.	9788858	ESCUTCHEON, Grille	1.268	
	2-	9790767 SCREW	1.269	
11.	9789373	GRILLE, R.H.	1.266	
12.	9747207	EMBLEM, Bumper	7.831	
	2-	9789776 SPACER	7.831	
	2-	#10-24 NUT, W/Washer	N.S.	
13.	9789374	GRILLE, L.H.	1.266	
14.	9788859	PLATE, "Pontiac"	1.303	
	2-	9789188 BRACKET	1.303	
	2-	9785896 RETAINER	1.303	
15.	9788858	ESCUTCHEON, Grille	1.268	
	2-	9790767 SCREW	1.269	

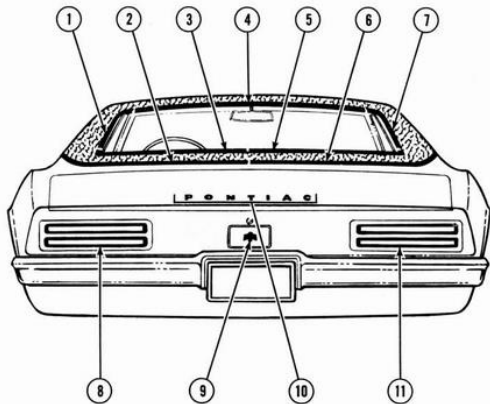

**1967 FIREBIRD HARDTOP COUPE—
REAR END VIEW—2337
(EXC. 400 SPORT OPTION)**

Key	Qty.	Part No.	Name	Group No.
1.		7639865	MOLDING, B/Wind. - Side	11.208
	2-	7639528	CLIP	11.209
	1-	7693140	CLIP	11.209
2.		3914077	MLDG. PKG., Belt	12.116
	6-	7638261	CLIP	12.118
	2-	7669079	CLIP	12.118
	2-	9419764	NUT	12.118
3.		7639867	MOLDING, B/Wind. - Lower	11.208
	4-	7639528	CLIP	11.209
4.		7639859	MOLDING, B/Wind. - Upper	11.208
	5-	7639528	CLIP	11.209
5.		7639866	MOLDING, B/Wind. - Lower	11.208
	4-	7639528	CLIP	11.209
6.		3914078	MLDG. PKG., Belt	12.116
	6-	7638261	CLIP	12.118
	2-	7669079	CLIP	12.118
	2-	9419764	NUT	12.118
7.		7639864	MOLDING, B/Wind. - Side	11.208
	2-	7639528	CLIP	11.209
	1-	7693140	CLIP	11.209
8.		5959712	HOUSING, Lamp	2.681
9.		9789710	EMBLEM, Fuel Door	12.945
	2-	9420621	NUT	8.148
10.		7712137	LETTER "P"	12.182
		7712138	LETTER "O"	12.182
		7712139	LETTER "N"	12.182
		7712140	LETTER "T"	12.182
		7712141	LETTER "I"	12.182
		7712142	LETTER "A"	12.182
		7712143	LETTER "C"	12.182
		12-9420201	NUT	8.921
11.		5959712	HOUSING, Lamp	2.681

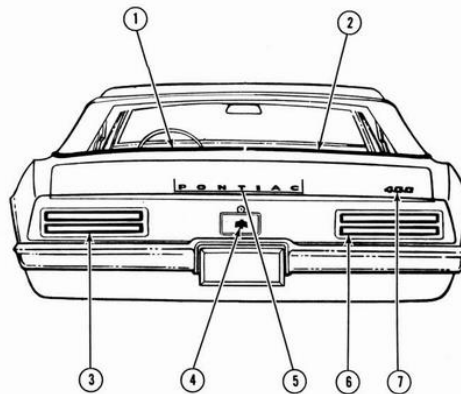

**1967 FIREBIRD CONVERTIBLE COUPE
REAR END VIEW—2367
(WITH 400 SPORT OPTION)**

Key	Qty.	Part No.	Name	Group No.
1.		3914091	MLDG. PKG., Pinch weld	12.116
	6-	7672609	CLIP	12.118
	7-	#8-18 x 1/2"	SCREW	N.S.
2.		3914092	MLDG. PKG., Pinch weld	12.116
	6-	7672609	CLIP	12.118
	7-	#8-18 x 1/2"	SCREW	N.S.
3.		5959712	HOUSING, Lamp	2.681
4.		9789710	EMBLEM, Fuel Door	12.945
	2-	9420621	NUT	8.148
5.		7712137	LETTER "P"	12.182
		7712138	LETTER "O"	12.182
		7712139	LETTER "N"	12.182
		7712140	LETTER "T"	12.182
		7712141	LETTER "I"	12.182
		7712142	LETTER "A"	12.182
		7712143	LETTER "C"	12.182
		12-9420201	NUT	8.921
6.		5959712	HOUSING, Lamp	2.681
7.		7728616	PLATE, "400"	12.182
	2-	9421827	NUT	8.921

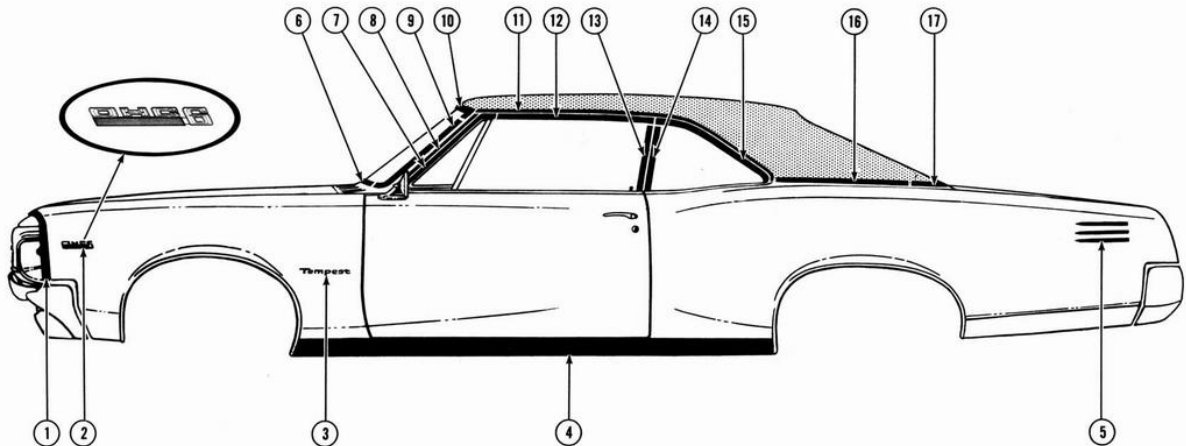

1967 TEMPEST 2-DOOR COUPE-3307 (O.H.C.-6 ENGINE & 2-TONE PAINT)

Key Qty.	Part No.	Name	Group No.	Key Qty.	Part No.	Name	Group No.
1.	9782752-53	BEZEL	2.728	9.	4541650-51	MOLDING, W/S - Side.	10.093
	4-9414754	SCREW	8.977		8-4474354	CLIP	10.096
	4-9423737	SCREW	2.729		8-#8-18 x 3/4"	SCREW	N.S.
	4-380382	NUT	2.729		4-4531604	SPACER	10.096
	4-3863669	NUT	2.729				
2.	9787806-07	EMBLEM, "O.H.C.-6"	8.147	10.	4541648-49	MOLDING, W/S - Upper	10.093
	4-9420621	NUT	8.148		8-4474354	CLIP	10.096
					8-#8-18 x 3/4"	SCREW	N.S.
3.	2-9787902	PLATE, "Tempest"	8.147	11.	4547733-34	SCALP, Roof	12.075
	6-9420621	NUT	8.148				
4.	9788949-50	MLDG. PKG., Rocker	8.304	12.	4547218-19	SCALP, Door - Upper	10.707
	2-9777710	CLIP PKG.	8.309				
5.	6-7681887	ORNAMENT	12.116	13.	4544920-21	SCALP, Door - Rear	10.707
	12-3/32" I.D. x 13/64" O.D. x 1/16"	Washer	N.S.				
	12-4528566	NUT	12.118	14.	7581320-21	MOLDING, Qtr. Wind. - Front.	11.031
6.	4430558	MOLDING, W/S - Lower	10.093	15.	4548436-37	MOLDING, Qtr. Wind. - Upr.	11.031
	7-4474354	CLIP	10.096				
	7-#8-18 x 3/4"	SCREW	N.S.	16.	7589524-25	MOLDING, Belt - Outer	12.116
	3-4531604	SPACER	10.096		8-7594209	CLIP	12.118
7.	4547690-91	SCALP, Door - Front	10.707	17.	7589292-93	MOLDING, Belt - Inner	12.116
					4-4817162	CLIP	12.118
8.	4543088-89	MOLDING, Pillar - Finish	10.093		4-7594209	CLIP	12.118
					4-9419763	NUT	12.118

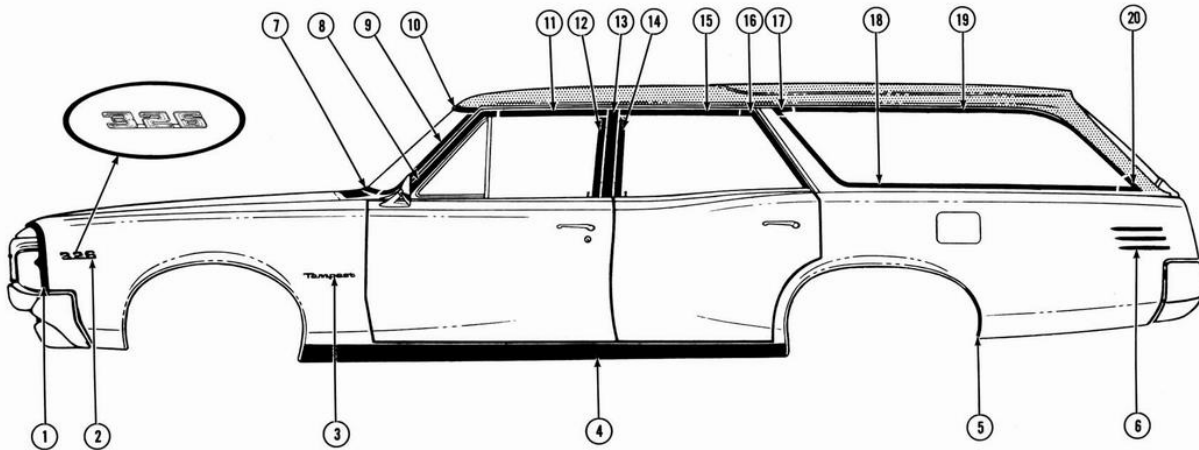

1967 TEMPEST 4-DOOR STATION WAGON—3335 (326 ENGINE & 2-TONE PAINT)

Key Qty.	Part No.	Name	Group No.	Key Qty.	Part No.	Name	Group No.
1.	9782752-53	BEZEL	2.728	10.	4430502-03	MOLDING, W/S - Upper (S/Steel)	10.093
	4-9414754	SCREW	8.977		4492998-99	MOLDING, W/S - Upper (Alum.)	10.093
	4-9423737	SCREW	2.729		8-4474354	CLIP (Use with S/Steel)	10.096
	4-380382	NUT	2.729		8-7698976	CLIP (Use with Alum.)	10.096
	4-3863699	NUT	2.729		8-#8-18 x 3/4"	SCREW	N.S.
2.	9787903-04	EMBLEM, "326"	8.147	11.	7582953-54	SCALP, Frt. Door - Upper	10.707
	4-9420621	NUT	8.148	12.	4464155-56	SCALP, Frt. Door - Rear	10.707
3.	9787902	PLATE, "Tempest"	8.147	13.	4424798-99	MOLDING, Pillar	12.113
	6-9420621	NUT	8.148		4-#8-18 x 3/8"	SCREW	N.S.
4.	9788949-50	MLDG. PKG., Rocker	8.304	14.	7603376-77	SCALP, Rr. Door - Front	10.772
	2-9777710	CLIP PKG.	8.309	15.	7582957-58	SCALP, Rr. Door - Upper	10.772
5.	4227184-85	MLDG. PKG., Stone	12.116	16.	4545618-19	SCALP, Rr. Door - Rear	10.772
	6-588546	SCREW	12.118	17.	4430413-14	ESCUTCHEON, Qtr. Window	11.031
6.	6-7681887	ORNAMENT	12.116	18.	4541767-68	MOLDING, Qtr. Wind. - Lower	11.031
	12-3/32" I.D. x 13/64" x 1/16"	Washer	N.S.		10-4474354	CLIP	11.032
	12-4528566	NUT	12.118		10-#8-18 x 3/4"	SCREW	N.S.
7.	4430558	MOLDING, W/S - Lower (S/Steel).	10.093		10-7600986	SPACER	11.032
	4493000	MOLDING, W/S - Lower (Alum.)	10.093	19.	4430942-43	MOLDING, Qtr. Wind. - Upr.	11.031
	7-4474354	CLIP (Use with S/Steel)	10.096		8-4474354	CLIP	11.032
	7-7698976	CLIP (Use with Alum.)	10.096		8-#8-18 x 3/4"	SCREW	N.S.
	7-#8-18 x 3/4"	SCREW	N.S.		10-7600986	SPACER	11.032
	3-4531604	SPACER (Use with S/Steel)	10.096	20.	4430413-14	ESCUTCHEON, Qtr. Wind.	11.031
	3-4511999	SPACER (Use with Alum.)	10.096				
8.	4411952-53	SCALP, Frt. Door - Front	10.707				
9.	4430500-01	MOLDING, W/S - Side (S/Steel)	10.093				
	4492995-96	MOLDING, W/S - Side (Alum.)	10.093				
	8-4474354	CLIP	10.096				
	8-#8-18 x 3/4"	SCREW	N.S.				
	4-4531604	SPACER (Use with S/Steel)	10.096				
	4-4511999	SPACER (Use with Alum.)	10.096				

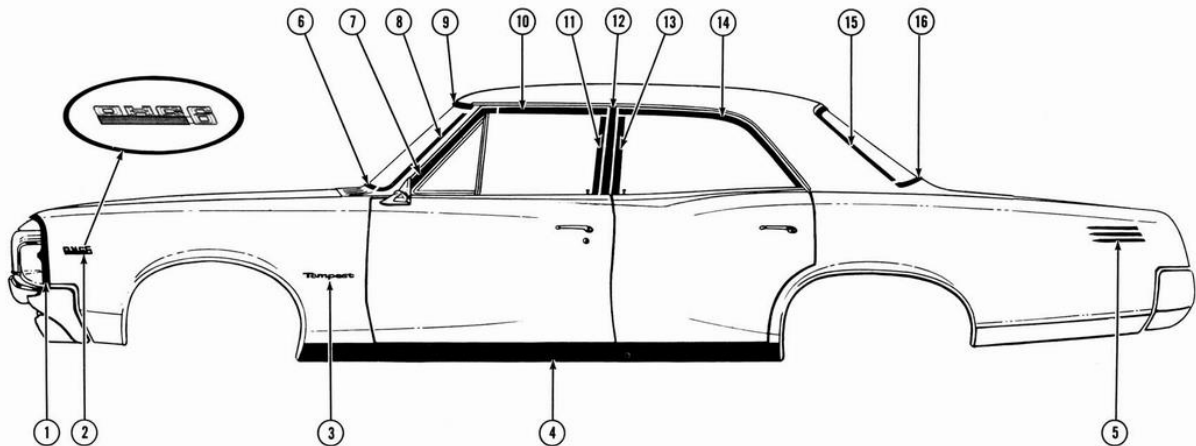

1967 TEMPEST 4-DOOR SEDAN—3369 (O.H.C.-6 SPRINT ENGINE)

Key Qty.	Part No.	Name	Group No.	Key Qty.	Part No.	Name	Group No.	
1.	9782752-53	BEZEL	2.728	8.	4430500-01	MOLDING, W/S-Side (S/Steel)	10.093	
	4-9414754	SCREW	8.977		4492995-96	MOLDING, W/S-Side (Alum.)	10.093	
	4-9423737	SCREW	2.729		8-4474354	CLIP	10.096	
	4-380382	NUT	2.729		8-#8-18 x 3/4"	SCREW	N.S.	
	4-3863699	NUT	2.729		4-4531604	SPACER (Use with S/Steel)	10.096	
2.	9788227-28	EMBLEM, "O.H.C.-6-Sprint"	8.147		4-4511999	SPACER (Use with Alum.)	10.096	
	4-9420621	NUT	8.148	9.	4430502-03	MOLDING, W/S - Upper (S/Steel)	10.093	
3.	2-9787902	PLATE, "Tempest"	8.147		4492998-99	MOLDING, W/S - Upper (Alum.)	10.093	
	6-9420621	NUT	8.148		8-4474354	CLIP (Use with S/Steel)	10.096	
4.	9788949-50	MLDG. PKG., Rocker	8.304		8-7698976	CLIP (Use with Alum.)	10.096	
	2-9777710	CLIP PKG.	8.309		8-#8-18 x 3/4"	SCREW	N.S.	
5.	6-7681887	ORNAMENT	12.116	10.	7582953-54	SCALP, Frt. Door - Upper	10.707	
	12-3/32" I.D. x 13/64" O.D. x 1/16"	Washer	N.S.		11.	4464155-56	SCALP, Frt. Door - Rear	10.707
	12-4528566	NUT	12.118		12.	4424798-99	MOLDING, Pillar	12.113
6.	4430558	MOLDING, W/S - Lower (S/Steel)	10.093			4-#8-18 x 3/8"	SCREW	N.S.
	4493000	MOLDING, W/S - Lower (Alum.)	10.093	13.	7603376-77	SCALP, Rr. Door - Front	10.772	
	7-4474354	CLIP (Use with S/Steel)	10.096		14.	4545378-79	SCALP, Rr. Door - Rear	10.772
	7-7698976	CLIP (Use with Alum.)	10.096	15.	4543010-11	MOLDING, B/Wind. - Upper	11.208	
	7-#8-18 x 3/4"	SCREW	N.S.			13-4474354	CLIP	11.209
	3-4531604	SPACER (Use with S/Steel)	10.096			4-4531604	SPACER	11.209
	3-4511999	SPACER (Use with Alum.)	10.096	16.	4543025-26	MOLDING, B/Wind. - Lower	11.208	
7.	4411952-53	SCALP, Frt. Door - Front	10.707			8-4474354	CLIP	11.209
						3-4531604	SPACER	11.209

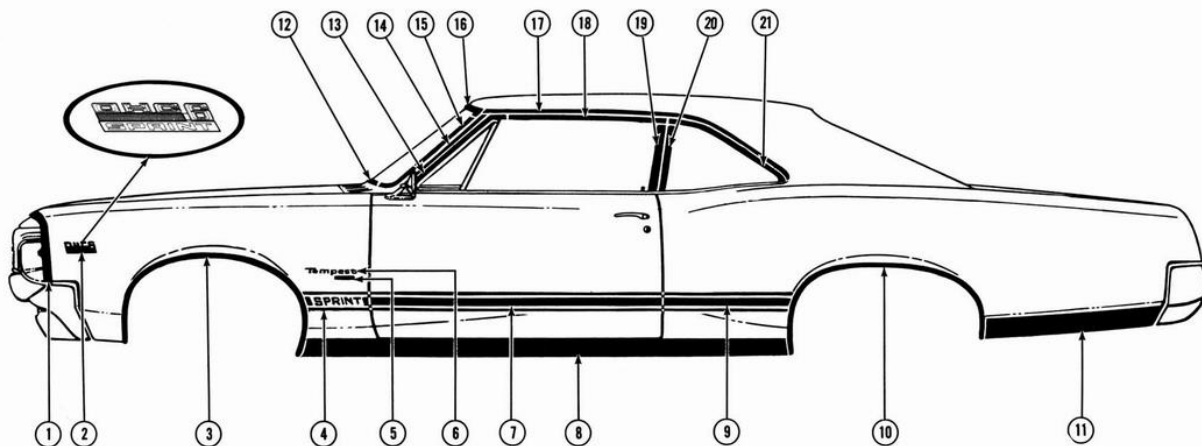

1967 TEMPEST CUSTOM 2-DOOR COUPE-3507 (W/SPRINT OPTION)

Key Qty.	Part No.	Name	Group No.	Key Qty.	Part No.	Name	Group No.	
1.	9782752-53	BEZEL	2.728	10.	4227182-83	MLDG. PKG., W/Opening	12.116	
	4-9414754	SCREW	8.977		14-588546	SCREW	12.118	
	4-9423737	SCREW	2.729	11.	4229729-30	MLDG. PKG., Rr. of W/Opng.	12.116	
	4-380382	NUT	2.729		2-9777698	CLIP PKG.	12.118	
	4-3863669	NUT	2.729	12.	4430558	MOLDING, W/S - Lower	10.093	
2.	9788227-28	EMBLEM, "O.H.C.-6-Sprint"	8.147		7-4474354	CLIP	10.096	
	4-9420621	NUT	8.148		7-#8-18 x 3/4"	SCREW	N.S.	
3.	9785448-49	MLDG. PKG., W/Opening	8.147		3-4531604	SPACER	10.096	
	16-588546	SCREW	8.148	13.	4547690-91	SCALP, Door - Front	10.707	
4.	9788248-49	STRIPES & LETTERS, Black	8.147	14.	4543088-89	MOLDING, Pillar - Finish	10.093	
	9788250-51	STRIPES & LETTERS, Red	8.147	15.	4541650-51	MOLDING, W/S - Side	10.093	
	9788252-53	STRIPES & LETTERS, White	8.147		8-4474354	CLIP	10.096	
5.	2-4440393	PLATE, "Custom"	8.147		8-#8-18 x 3/4"	SCREW	N.S.	
	4-9420621	NUT	8.148		4-4531604	SPACER	10.096	
6.	2-9787902	PLATE, "Tempest"	8.147	16.	4541648-49	MOLDING, W/S - Upper	10.093	
	6-9420621	NUT	8.148		8-4474354	CLIP	10.096	
7.	2-9788273	STRIPE, Black	12.112		8-#8-18 x 3/4"	SCREW	N.S.	
	2-9788274	STRIPE, Red	12.112	17.	4547733-34	SCALP, Roof	12.075	
	2-9788275	STRIPE, White	12.112	18.	4547218-19	SCALP, Door - Upper	10.707	
8.	9788949-50	MLDG. PKG., Rocker	8.304		19.	4544920-21	SCALP, Door - Rear	10.707
	2-9777710	CLIP PKG.	8.309	20.	7581320-21	MOLDING, Qtr. Wind. - Front	11.031	
9.	9788276-77	STRIPE, Black	12.116		21.	4548436-37	MOLDING, Qtr. Wind. - Upper	11.031
	9788278-79	STRIPE, Red	12.116					
	9788280-81	STRIPE, White	12.116					

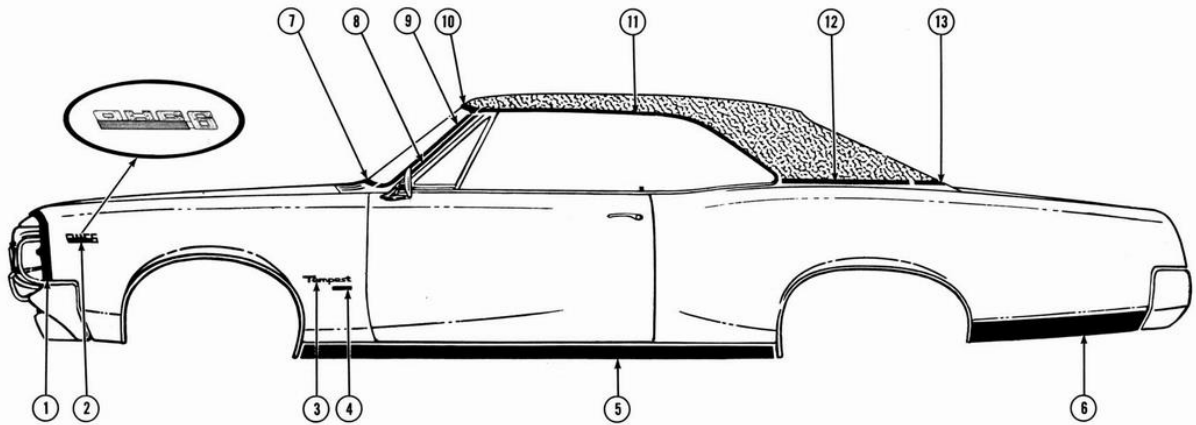

1967 TEMPEST CUSTOM 2-DOOR SPORT COUPE—3517 (O.H.C.-6 ENGINE & CORDOVA TOP)

Key Qty.	Part No.	Name	Group No.	Key Qty.	Part No.	Name	Group No.
1.	9782752-53	BEZEL	2.728	8.	4543090-91	MOLDING, Pillar - Finish . . .	10.093
	4-9414754	SCREW	8.977				
	4-9423737	SCREW	2.729				
	4-380382	NUT	2.729	9.	4541650-51	MOLDING, W/S - Side	10.093
	4-3863669	NUT	2.729		8-4474354	CLIP	10.096
					8-#8-18 x 3/4"	SCREW	N.S.
					4-4531604	SPACER	10.096
2.	9787806-07	EMBLEM, "O.H.C.-6"	8.147				
	4-9420621	NUT	8.148	10.	4541648-49	MOLDING, W/S - Upper . . .	10.093
					8-4474354	CLIP	10.096
3.	2-9787902	PLATE, "Tempest"	8.147		8-#8-18 x 3/4"	SCREW	N.S.
	6-9420621	NUT	8.148	11.	4547733-34	SCALP, Roof	12.075
4.	2-4440393	PLATE, "Custom"	8.147				
	4-9420621	NUT	8.148	12.	7589524-25	MOLDING, Belt-Outer	12.116
5.	9788949-50	MLDG. PKG., Rocker	8.304		8-7617597	CLIP	12.118
	2-9777710	CLIP PKG.	8.309	13.	7589292-93	MOLDING, Belt-Inner	12.116
6.	4229729-30	MLDG. PKG., Rr. of W/Opng. .	12.116		4-4817162	CLIP	12.118
	2-9777698	CLIP PKG.	12.118		4-7617597	CLIP	12.118
7.	4430558	MOLDING, W/S - Lower	10.093		4-9419763	NUT	12.118
	7-4474354	CLIP	10.096				
	7-#8-18 x 3/4"	SCREW	N.S.				
	3-4531604	SPACER.	10.096				

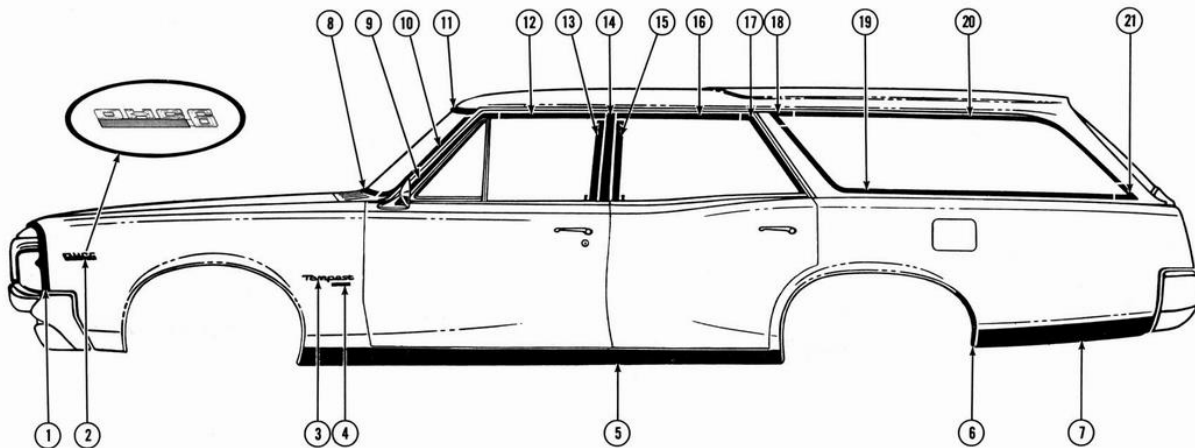

1967 TEMPEST CUSTOM 4-DOOR STATION WAGON—3535 (O.H.C.-6 ENGINE)

Key Qty.	Part No.	Name	Group No.	Key Qty.	Part No.	Name	Group No.
1.	9782752-53	BEZEL	2.728	10.	4430500-01	MOLDING, W/S - Side (S/Steel)	10.093
	4-9414754	SCREW	8.977		4492995-96	MOLDING, W/S - Side (Alum.)	10.093
	4-9423737	SCREW	2.729		8-4474354	CLIP	10.096
	4-380382	NUT	2.729		9-#8-18 x 3/4"	SCREW	N.S.
	4-3863699	NUT	2.729		4-4531604	SPACER (Use with S/Steel)	10.096
					4-4511999	SPACER (Use with Alum.)	10.096
2.	9787806-07	EMBLEM, "O.H.C.-6"	8.147	11.	4430502-03	MOLDING, W/S - Upper (S/Steel)	10.093
	4-9420621	NUT	8.148		4492998-99	MOLDING, W/S - Upper (Alum.)	10.093
3.	2-9787902	PLATE, "Tempest"	8.147		8-4474354	CLIP (Use with S/Steel)	10.096
	6-9420621	NUT	8.148		8-7698976	CLIP (Use with Alum.)	10.096
					8-#8-18 x 3/4"	SCREW	N.S.
4.	2-4440393	PLATE, "Custom"	8.147	12.	7582953-54	SCALP, Frt. Door - Upper	10.707
	4-9420621	NUT	8.148	13.	4464155-56	SCALP, Frt. Door - Rear	10.707
5.	9788949-50	MLDG. PKG., Rocker	8.304	14.	4424798-99	MOLDING, Pillar	12.113
	2-9777710	CLIP PKG.	8.309		4-#8-18 x 3/8"	SCREW	N.S.
6.	4227184-85	MLDG. PKG., Stone	12.116	15.	7603376-77	SCALP, Rr. Door - Front	10.772
	6-588546	SCREW	12.118	16.	7582957-58	SCALP, Rr. Door - Upper	10.772
7.	4229731-32	MLDG. PKG., Rr. of W/Opng.	12.116	17.	4545618-19	SCALP, Rr. Door - Rear	10.772
	2-9777698	CLIP PKG.	12.118	18.	4430413-14	ESCUTCHEON, Qtr. Window	11.031
8.	4430558	MOLDING, W/S - Lower (S/Steel)	10.093	19.	4541767-68	MOLDING, Qtr. Wind. - Lwr.	11.031
	4493000	MOLDING, W/S - Lower (Alum.)	10.093		10-4474354	CLIP	11.032
	7-4474354	CLIP (Use with S/Steel)	10.096		10-#8-18 x 3/4"	SCREW	N.S.
	7-7698976	CLIP (Use with Alum.)	10.096		10-7600986	SPACER	11.032
	7-#8-18 x 3/4"	SCREW	N.S.	20.	4430942-43	MOLDING, Qtr. Wind. - Upr.	11.031
	3-4531604	SPACER (Use with S/Steel)	10.096		8-4474354	CLIP	11.032
	3-4511999	SPACER (Use with Alum.)	10.096		8-#8-18 x 3/4"	SCREW	N.S.
					10-7600986	SPACER	11.032
9.	4411952-53	SCALP, Frt. Door - Front	10.707	21.	4430413-14	ESCUTCHEON, Qtr. Window	11.031

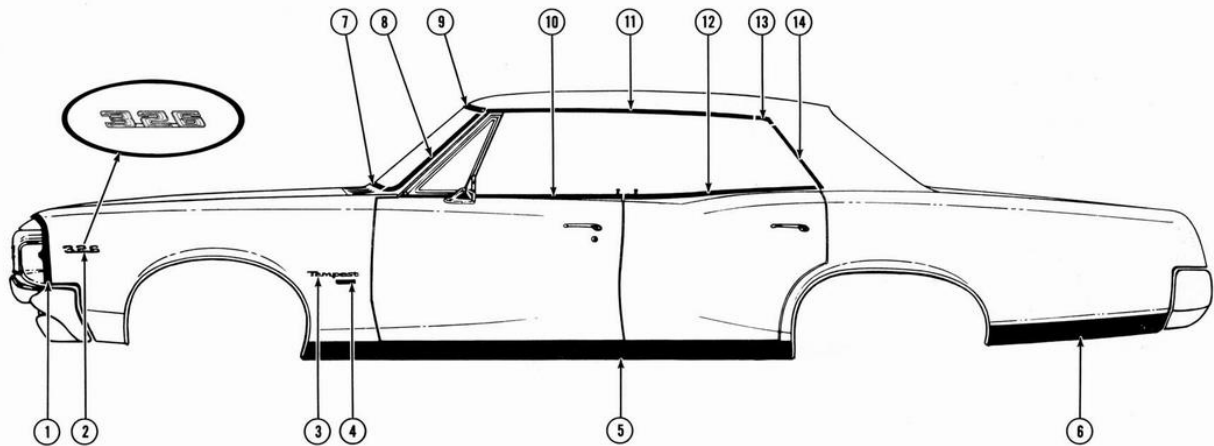

1967 TEMPEST CUSTOM 4-DOOR HARDTOP—3539 (326 ENGINE)

Key Qty.	Part No.	Name	Group No.	Key Qty.	Part No.	Name	Group No.
1.	9782752-53	BEZEL	2.728	8.	4430500-01	MOLDING, W/S - Side (S/Steel)	10.093
	4-9414754	SCREW	8.977		4492995-96	MOLDING, W/S - Side (Alum.)	10.093
	4-9423737	SCREW	2.729		8-4474354	CLIP	10.096
	4-380382	NUT	2.729		8-#8-18 x 3/4"	SCREW	N.S.
	4-3863699	NUT	2.729		4-4531604	SPACER (Use with S/Steel)	10.096
					4-4511999	SPACER (Use with Alum.)	10.096
2.	9787903-04	EMBLEM, "326"	8.147	9.	4430502-03	MOLDING, W/S - Upper (S/Steel)	10.093
	4-9420621	NUT	8.148		4492998-99	MOLDING, W/S - Upper (Alum.)	10.093
3.	2-9787902	PLATE, "Tempest"	8.147		8-4474354	CLIP (Use with S/Steel)	10.096
	6-9420621	NUT	8.148		8-7698976	CLIP (Use with Alum.)	10.096
4.	2-4440393	PLATE, "Custom"	8.147		8-#8-18 x 3/4"	SCREW	N.S.
	4-9420621	NUT	8.148	10.	7581961-62	MOLDING, Frt. Door - Wind.	10.707
5.	9788949-50	MLDG. PKG., Rocker	8.304		4-#8-18 x 1/2"	SCREW	N.S.
	2-9777710	CLIP PKG.	8.309	11.	4540945-46	SCALP, Roof - Front	12.075
6.	4229729-30	MLDG. PKG., Rr. of W/Opng.	12.116	12.	7582515-16	MOLDING, Rr. Door - Wind.	10.772
	2-9777698	CLIP PKG.	12.118		4-#8-18 x 1/2"	SCREW	N.S.
7.	4430558	MOLDING, W/S - Lower (S/Steel)	10.093	13.	2-4545260	ESCUTCHEON, Roof	12.075
	4493000	MOLDING, W/S - Lower (Alum.)	10.093	14.	4541082-83	SCALP, Roof - Rear	12.075
	7-4474354	CLIP (Use with S/Steel)	10.096				
	7-7698976	CLIP (Use with Alum.)	10.096				
	7-#8-18 x 3/4"	SCREW	N.S.				
	3-4531604	SPACER (Use with S/Steel)	10.096				
	3-4511999	SPACER (Use with Alum.)	10.096				

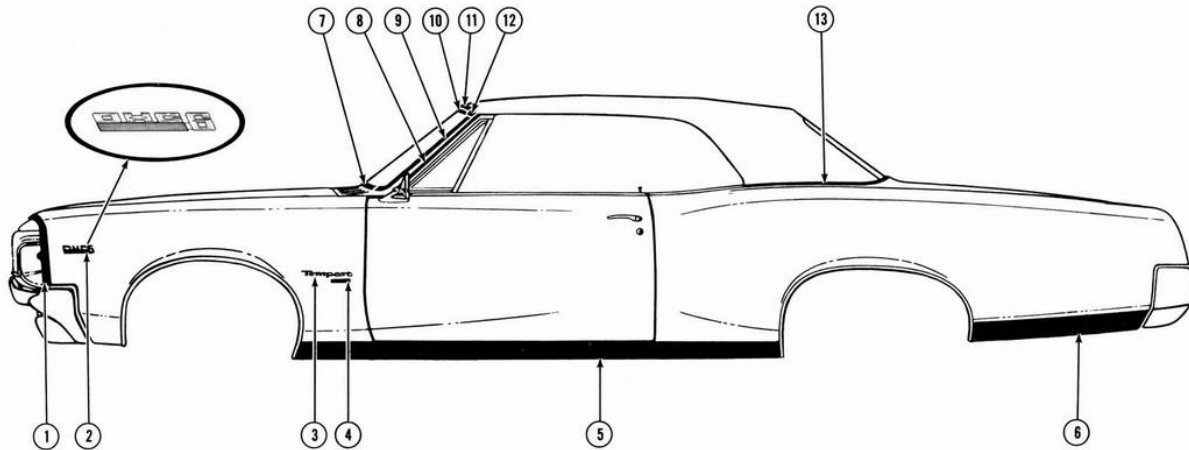

1967 TEMPEST CUSTOM CONVERTIBLE COUPE—3567 (O.H.C.-6 ENGINE)

Key Qty.	Part No.	Name	Group No.	Key Qty.	Part No.	Name	Group No.
1.	9782752-53	BEZEL	2.728	7.	4430558	MOLDING, W/S - Lower	10.093
	4-9414754	SCREW	8.977		7-4474354	CLIP	10.096
	4-9423737	SCREW	2.729		7-#8-18 x 3/4"	SCREW	N.S.
	4-380382	NUT	2.729		3-4531604	SPACER	10.096
	4-3863669	NUT	2.729	8.	4543092-93	MOLDING, Pillar - Finish	10.093
2.	9787806-07	EMBLEM, "O.H.C.-6".	8.147	9.	4541650-51	MOLDING, W/S - Side.	10.093
	4-9420621	NUT	8.148		8-4474354	CLIP	10.096
					8-#8-18 x 3/4"	SCREW	N.S.
					4-4531604	SPACER	10.096
3.	2-9787902	PLATE, "Tempest".	8.147	10.	4541648-49	MOLDING, W/S - Upper	10.093
	6-9420621	NUT	8.148		8-4474354	CLIP	10.096
					8-#8-18 x 3/4"	SCREW	N.S.
4.	2-4440393	PLATE, "Custom".	8.147	11.	4542518	HEADER, Center	10.093
	4-9420621	NUT	8.148		4-4409925	SCREW	10.096
5.	9788949-50	MLDG. PKG., Rocker	8.304	12.	4542516-17	HEADER, Side	10.093
	2-9777710	CLIP PKG.	8.309		2-4409925	SCREW	10.096
6.	4229729-30	MLDG. PKG., Rr. of W/Opng..	12.116	13.	4541662-63	MOLDING, Finish	12.116
	2-9777698	CLIP PKG.	12.118		16-7584999	CLIP.	12.118

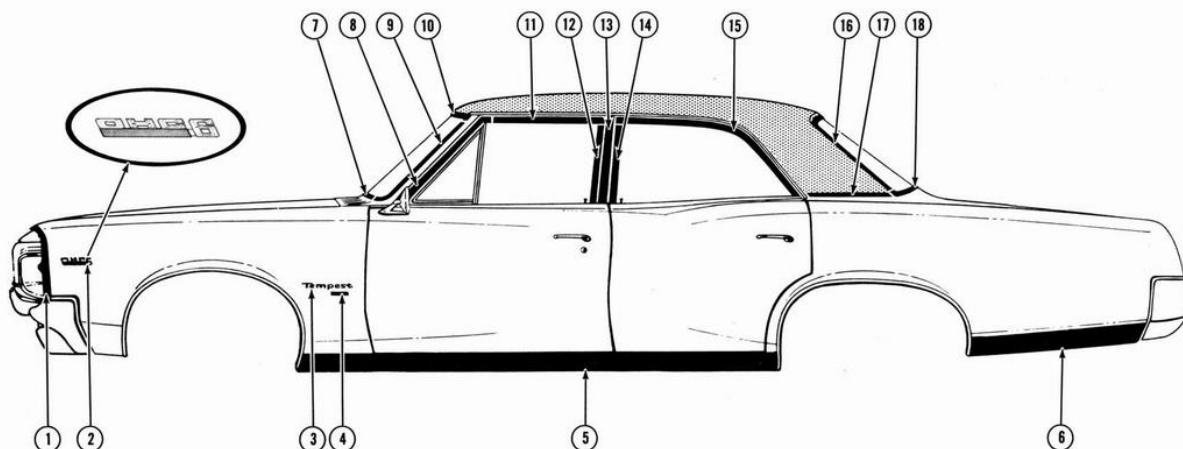

1967 TEMPEST CUSTOM 4-DOOR SEDAN—3569 (O.H.C.-6 ENGINE & 2-TONE PAINT)

Key Qty.	Part No.	Name	Group No.	Key Qty.	Part No.	Name	Group No.
1.	9782752-53	BEZEL	2.728	9.	4430500-01	MOLDING, W/S - Side (S/Steel)	10.093
	4-9414754	SCREW	8.977		4492995-96	MOLDING, W/S - Side (Alum.)	10.093
	4-9423737	SCREW	2.729		8-4474354	CLIP	10.096
	4-380382	NUT	2.729		8-#8-18 x 3/4"	SCREW	N.S.
	4-3863669	NUT	2.729		4-4531604	SPACER (Use with S/Steel)	10.096
					4-4511999	SPACER (Use with Alum.)	10.096
2.	9787806-07	EMBLEM, "O.H.C.-6"	8.147	10.	4430502-03	MOLDING, W/S - Upper (S/Steel)	10.093
	4-9420621	NUT	8.148		4492998-99	MOLDING, W/S - Upper (Alum.)	10.093
3.	2-9787902	PLATE, "Tempest"	8.147		8-4474354	CLIP (Use with S/Steel)	10.096
	6-9420621	NUT	8.148		8-7698976	CLIP (Use with Alum.)	10.096
4.	2-4440393	PLATE "Custom"	8.147		8-#8-18 x 3/4"	SCREW	N.S.
	4-9420621	NUT	8.148	11.	7582953-54	SCALP, Frt. Door - Upper	10.707
5.	9788949-50	MLDG. PKG., Rocker	8.304	12.	4464155-56	SCALP, Frt. Door - Rear	10.707
	2-9777710	CLIP PKG.	8.309	13.	4424798-99	MOLDING, Pillar	12.113
6.	4229729-30	MLDG. PKG., Rr. of W/Opng.	12.116		4-#8-18 x 3/8"	SCREW	N.S.
	2-9777698	CLIP PKG.	12.118	14.	7603376-77	SCALP, Rr. Door - Front	10.772
7.	4430558	MOLDING, W/S - Lower (S/Steel)	10.093	15.	4545378-79	SCALP, Rr. Door - Rear	10.772
	4493000	MOLDING, W/S - Lower (Alum.)	10.093	16.	4543010-11	MOLDING, B/Wind. - Upper	11.208
	7-4474354	CLIP (Use with S/Steel)	10.096		13-4474354	CLIP	11.209
	7-7698976	CLIP (Use with Alum.)	10.096		4-4531604	SPACER	11.209
	7-#8-18 x 3/4"	SCREW	N.S.	17.	7586892-93	MOLDING, Belt	12.116
	3-4531604	SPACER (Use with S/Steel)	10.096		4-7584569	CLIP	11.032
	3-4511999	SPACER (Use with Alum.)	10.096		2-7606503	CLIP	11.032
8.	4411952-53	SCALP, Frt. Door - Front	10.707	18.	4543025-26	MOLDING, B/Wind. - Lower	11.208
					8-4474354	CLIP	11.209
					3-4531604	SPACER	11.209

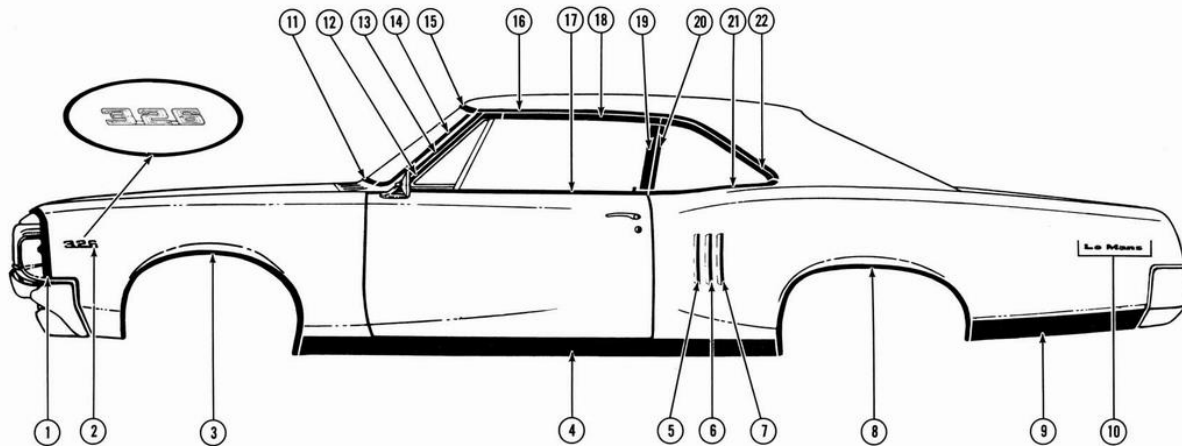

1967 LE MANS 2-DOOR COUPE—3707 (326 ENGINE)

Key Qty.	Part No.	Name	Group No.	Key Qty.	Part No.	Name	Group No.
1.	9782752-53	BEZEL	2.728	11.	4430558	MOLDING, W/S - Lower	10.093
	4-9414754	SCREW	8.977		7-4474354	CLIP	10.096
	4-9423737	SCREW	2.729		7-#8-18 x 3/4"	SCREW	N.S.
	4-380382	NUT	2.729		3-4531604	SPACER	10.096
	4-3863669	NUT	2.729				
2.	9787903-04	EMBLEM, "326"	8.147	12.	4547690-91	SCALP, Door - Front	10.707
	4-9420621	NUT	8.148				
3.	9785448-49	MLDG. PKG., W/Opening	8.147	13.	4543088-89	MOLDING, Pillar - Finish	10.093
	16-588546	SCREW	8.148				
4.	9788949-50	MLDG. PKG., Rocker	8.304	14.	4541650-51	MOLDING, W/S - Side	10.093
	2-9777710	CLIP PKG.	8.309		8-4474354	CLIP	10.096
					8-#8-18 x 3/4"	SCREW	N.S.
					4-4531604	SPACER	10.096
5.	2-4229733	MLDG. PKG., Louver - Front	12.116	15.	4541648-49	MOLDING, W/S - Upper	10.093
	2-9777699	CLIP PKG.	12.118		8-4474354	CLIP	10.096
					8-#8-18 x 3/4"	SCREW	N.S.
6.	2-4229734	MLDG. PKG., Louver - Center	12.116	16.	4547733-34	SCALP, Roof	12.075
	2-9777699	CLIP PKG.	12.118				
7.	2-4229735	MLDG. PKG., Louver - Rear	12.116	17.	7580768-69	MOLDING, Door - Window	10.707
	2-9777699	CLIP PKG.	12.118		8-#8-18 x 1/2"	SCREW	N.S.
8.	4227182-83	MLDG. PKG., W/Opening	12.116	18.	4547218-19	SCALP, Door - Upper	10.707
	14-588546	SCREW	12.118				
9.	4229729-30	MLDG. PKG., Rr. of W/Opng.	12.116	19.	4544920-21	SCALP, Door - Rear	10.707
	2-9777698	CLIP PKG.	12.118				
10.	2-7670136	LETTER "L"	12.116	20.	7581320-21	MOLDING, Qtr. Wind. - Front.	11.031
	2-7670137	LETTER "E"	12.116				
	2-7670138	LETTER "M"	12.116	21.	7580595-96	MOLDING, Qtr. Window	11.031
	2-7670139	LETTER "A"	12.116		6-#8-18 x 1/2"	SCREW	N.S.
	2-7670140	LETTER "N"	12.116				
	2-7670141	LETTER "S"	12.116	22.	4548436-37	MOLDING, Qtr. Wind. - Upr.	11.031
	12-3/32" I.D. x 13/64" O.D. x 1/16"	Washer	N.S.				
	12-9419764	NUT	12.118				

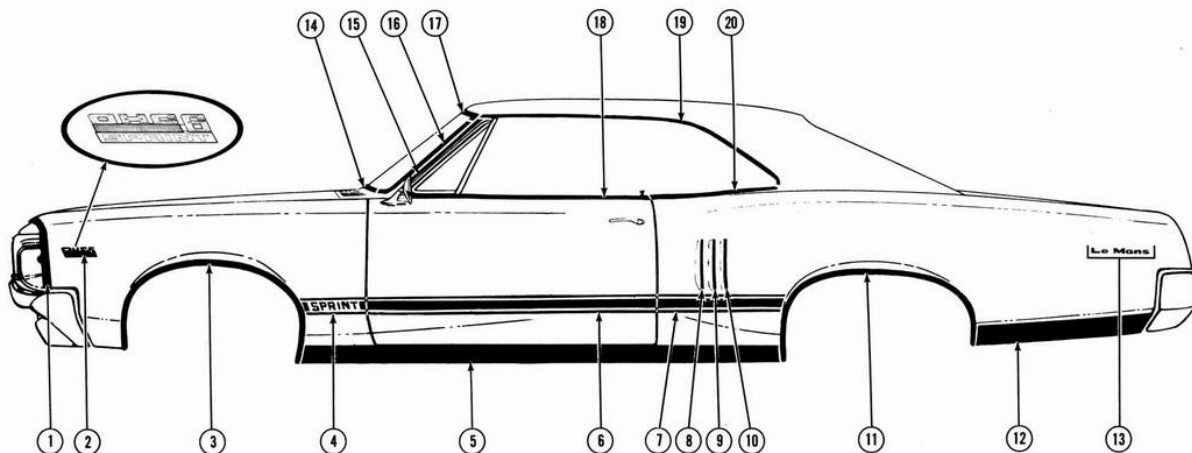

1967 LE MANS 2-DOOR SPORT COUPE-3717 (W/SPRINT OPTION)

Key Qty.	Part No.	Name	Group No.	Key Qty.	Part No.	Name	Group No.
1.	9782752-53	BEZEL	2.728	12.	4229729-30	MLDG. PKG., Rr. of W/Opng.	12.116
	4-9414754	SCREW	8.977		2-9777698	CLIP PKG.	12.118
	4-9423737	SCREW	2.729				
	4-380382	NUT	2.729				
	4-3863669	NUT	2.729				
2.	9788227-28	EMBLEM, "O.H.C.-6-Sprint"	8.147	13.	2-7670136	LETTER "L"	12.116
	4-9420621	NUT	8.148		2-7670137	LETTER "E"	12.116
					2-7670138	LETTER "M"	12.116
					2-7670139	LETTER "A"	12.116
					2-7670140	LETTER "N"	12.116
					2-7670141	LETTER "S"	12.116
3.	9785448-49	MLDG. PKG., W/Opening	8.147		12-3/32" I.D. x 13/64" O.D. x 1/16"		
	16-588546	SCREW	8.148		Washer	N.S.	
					12-9419764	NUT	12.118
4.	9788248-49	STRIPES & LETTERS, Black	8.147	14.	4430558	MOLDING, W/S - Lower.	10.093
	9788250-51	STRIPES & LETTERS, Red	8.147		7-4474354	CLIP	10.096
	9788252-53	STRIPES & LETTERS, White	8.147		7-#8-18 x 3/4"	SCREW	N.S.
					3-4531604	SPACER.	10.096
5.	9788949-50	MLDG. PKG., Rocker	8.304	15.	4543090-91	MOLDING, Pillar - Finish	10.093
	2-9777710	CLIP PKG.	8.309				
6.	2-9788273	STRIPE, Black	12.112	16.	4541650-51	MOLDING, W/S - Side	10.093
	2-9788274	STRIPE, Red	12.112		8-4474354	CLIP	10.096
	2-9788275	STRIPE, White	12.112		8-#8-18 x 3/4"	SCREW	N.S.
					4-4531604	SPACER.	10.096
7.	9788276-77	STRIPE, Black	12.116	17.	4541648-49	MOLDING, W/S - Upper	10.093
	9788278-79	STRIPE, Red	12.116		8-4474354	CLIP	10.096
	9788280-81	STRIPE, White	12.116		8-#8-18 x 3/4"	SCREW	N.S.
8.	2-4229733	MLDG. PKG., Louver - Front.	12.116	18.	7580770-71	MOLDING, Door - Window	10.707
	2-9777699	CLIP PKG.	12.118		8-#8-18 x 1/2"	SCREW	N.S.
9.	2-4229734	MLDG. PKG., Louver - Center	12.116	19.	4547733-34	SCALP, Roof	12.075
	2-9777699	CLIP PKG.	12.118				
10.	2-4229735	MLDG. PKG., Louver - Rear	12.116	20.	7580593-94	MOLDING, Qtr. Window	11.031
	2-9777699	CLIP PKG.	12.118				
11.	4227182-83	MLDG. PKG., W/Opening	12.116				
	14-588546	SCREW	12.118				

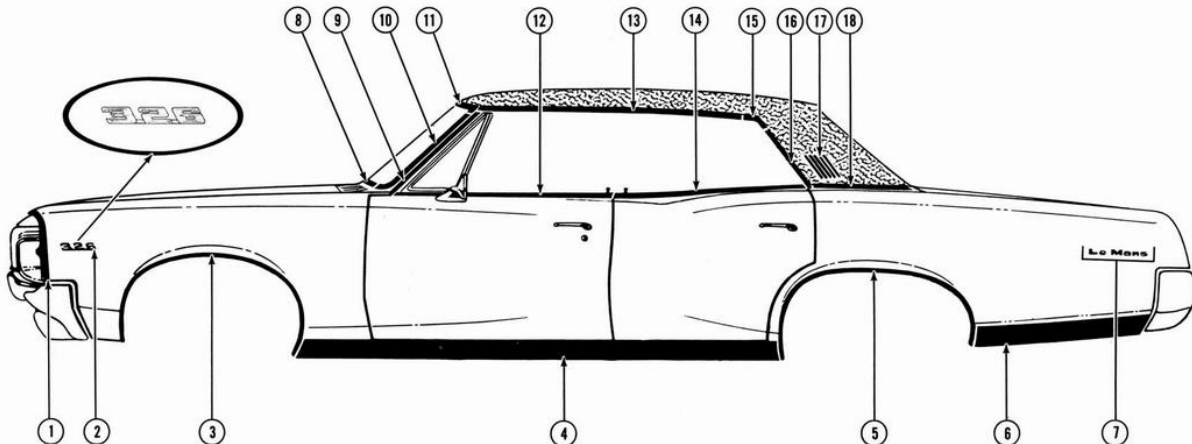

1967 LE MANS 4-DOOR HARDTOP—3739 (326 ENGINE & CORDOVA TOP)

Key Qty.	Part No.	Name	Group No.	Key Qty.	Part No.	Name	Group No.
1.	9782752-53	BEZEL	2.728	9.	4456263-64	MOLDING, Pillar - Finish . . .	10.093
	4-9414754	SCREW	8.977	10.	4430500-01	MOLDING, W/S - Side (S/Steel)	10.093
	4-9423737	SCREW	2.729		4492995-96	MOLDING, W/S - Side (Alum.) .	10.093
	4-380382	NUT	2.729		8-4474354	CLIP	10.096
	4-3863669	NUT	2.729		8-#8-18 x 3/4"	SCREW	N.S.
2.	9787903-04	EMBLEM, "326"	8.147		4-4531604	SPACER (Use with S/Steel) . .	10.096
	4-9420621	NUT	8.148		4-4511999	SPACER (Use with Alum.) . . .	10.096
3.	9785448-49	MLDG. PKG., W/Opening . . .	8.147	11.	4430502-03	MOLDING, W/S - Upper (S/Steel)	10.093
	16-588546	SCREW	8.148		4492998-99	MOLDING, W/S - Upper (Alum.)	10.093
4.	9788949-50	MLDG. PKG., Rocker	8.304		8-4474354	CLIP (Use with S/Steel)	10.096
	2-9777710	CLIP PKG.	8.309		8-7698976	CLIP (Use with Alum.)	10.096
5.	4227182-83	MLDG. PKG., W/Opening . . .	12.116		8-#8-18 x 3/4"	SCREW	10.096
	14-588546	SCREW	12.118	12.	7581961-62	MOLDING, Frt. Door - Wind. .	10.707
6.	4229729-30	MLDG. PKG., Rr. of W/Opng. .	12.116		4-#8-18 x 1/2"	SCREW	N.S.
	2-9777698	CLIP PKG.	12.118	13.	4540945-46	SCALP, Roof - Front	12.075
7.	2-7670136	LETTER "L"	12.116	14.	7582515-16	MOLDING, Rr. Door - Wind. . .	10.772
	2-7670137	LETTER "E"	12.116		4-#8-18 x 1/2"	SCREW	N.S.
	2-7670138	LETTER "M"	12.116	15.	2-4545260	ESCUTCHEON, Roof	12.075
	2-7670139	LETTER "A"	12.116	16.	4541082-83	SCALP, Roof - Rear	12.075
	2-7670140	LETTER "N"	12.116	17.	10-7686349	MOLDING, Roof - Louver	12.812
	2-7670141	LETTER "S"	12.116		20-9419763	NUT	12.118
	12-3/32" I.D. x 13/64" O.D. x 1/16"	Washer	N.S.	18.	7586890-91	MOLDING, Belt	12.116
	12-4528566	NUT	12.118		4-7584569	CLIP	12.118
8.	4430558	MOLDING, W/S - Lower (S/Steel) .	10.093		2-4817162	CLIP	12.118
	4493000	MOLDING, W/S - Lower (Alum.) . .	10.093		2-9419764	NUT	12.118
	7-4474354	CLIP (Use with S/Steel)	10.096				
	7-7698976	CLIP (Use with Alum.)	10.096				
	7-#8-18 x 3/4"	SCREW	N.S.				
	3-4531604	SPACER (Use with S/Steel) . . .	10.096				
	3-4511999	SPACER (Use with Alum.)	10.096				

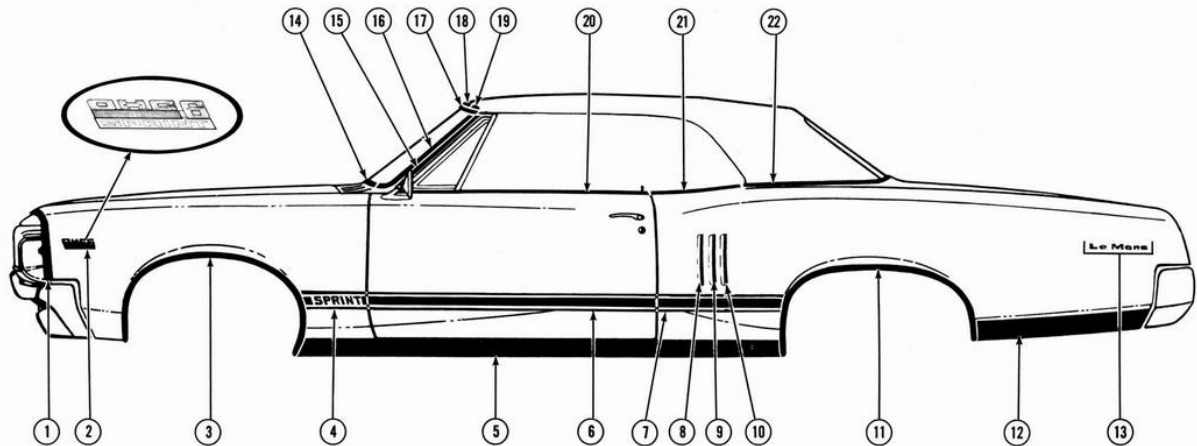

1967 LE MANS CONVERTIBLE COUPE—3767 (W/SPRINT OPTION)

Key Qty.	Part No.	Name	Group No.	Key Qty.	Part No.	Name	Group No.
1.	9782752-53	BEZEL	2.728	13.	2-7670136	LETTER "L"	12.116
	4-9414754	SCREW	8.977		2-7670137	LETTER "E"	12.116
	4-9423737	SCREW	2.729		2-7670138	LETTER "M"	12.116
	4-380382	NUT	2.729		2-7670139	LETTER "A"	12.116
	4-3863669	NUT	2.729		2-7670140	LETTER "N"	12.116
2.	9788227-28	EMBLEM, "O.H.C.-6-Sprint"	8.147		2-7670141	LETTER "S"	12.116
	4-9420621	NUT	8.148		12-3/32" I.D. x 13/64" O.D. x 1/16"	Washer	N.S.
3.	9785448-49	MLDG. PKG., W/Opening	8.147		12-9419764	NUT	12.118
	16-588546	SCREW	8.148	14.	4430558	MOLDING, W/S - Lower	10.093
4.	9788248-49	STRIPES & LETTERS, Black	8.147		7-4474354	CLIP	10.096
	9788250-51	STRIPES & LETTERS, Red	8.147		7-#8-18 x 3/4"	SCREW	N.S.
	9788252-53	STRIPES & LETTERS, White	8.147		3-4531604	SPACER	10.096
5.	9788949-50	MLDG. PKG., Rocker	8.304	15.	4543092-93	MOLDING, Pillar - Finish	10.093
	2-9777710	CLIP PKG.	8.309	16.	4541650-51	MOLDING, W/S - Side	10.093
6.	2-9788273	STRIPE, Black	12.112		8-4474354	CLIP	10.096
	2-9788274	STRIPE, Red	12.112		8-#8-18 x 3/4"	SCREW	N.S.
	2-9788275	STRIPE, White	12.112		4-4531604	SPACER	10.096
7.	9788276-77	STRIPE, Black	12.116	17.	4541648-49	MOLDING, W/S - Upper	10.093
	9788278-79	STRIPE, Red	12.116		8-4474354	CLIP	10.096
	9788280-81	STRIPE, White	12.116		8-#8-18 x 3/4"	SCREW	N.S.
8.	2-4229733	MLDG. PKG., Louver - Front	12.116	18.	4542518	HEADER, Center	10.093
	2-9777699	CLIP PKG.	12.118		4-4409925	SCREW	10.096
9.	2-4229734	MLDG. PKG., Louver - Center	12.116	19.	4542516-17	HEADER, Side	10.093
	2-9777699	CLIP PKG.	12.118		2-4409925	SCREW	10.096
10.	2-4229735	MLDG. PKG., Louver - Rear	12.116	20.	7582451-52	MOLDING, Door - Window	10.707
	2-9777699	CLIP PKG.	12.118		8-#8-18 x 1/2"	SCREW	N.S.
11.	4227182-83	MLDG. PKG., W/Opening	12.116	21.	4541660-61	MOLDING, Qtr. Window	11.031
	14-588546	SCREW	12.118		6-#8-18 x 1/2"	SCREW	N.S.
12.	4229729-30	MLDG. PKG., Rr. of W/Opng.	12.116	22.	4541666-67	MOLDING, Finish	12.116
	2-9777698	CLIP PKG.	12.118		16-7584999	CLIP	12.118

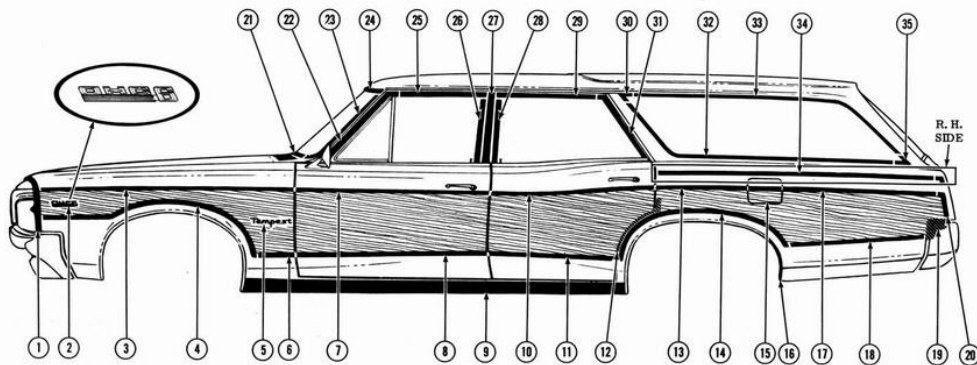

1967 SAFARI 4-DOOR STATION WAGON—3935

Key Qty.	Part No.	Name	Group No.	Key Qty.	Part No.	Name	Group No.
1.	9782752-53	BEZEL	2.728	19.	4229942-43	MLDG.PKG.,Behind Bumper-Painted	12.116
	4-9414754	SCREW	8.977		6-#8-18 x 3/8"	SCREW	N.S.
	4-9423737	SCREW	2.729	20.	4229944-45	MLDG. PKG., Qtr. Vertical	12.116
	4-380382	NUT	2.729		4-7584569	CLIP	12.118
	4-3863669	NUT	2.729	21.	4430558	MOLDING, W/S - Lower (S/Steel)	10.093
2.	9787806-07	EMBLEM, "O.H.C.-6"	8.147		4493000	MOLDING, W/S - Lower (Alum.)	10.093
	4-9420621	NUT	8.148		7-4474354	CLIP (Use with S/Steel)	10.096
3.	2-9788965	MLDG. PKG., Fender - Upper	8.147		7-7698976	CLIP (Use with Alum.)	10.096
	2-9777714	CLIP PKG.	8.148		7-#8-18 x 3/4"	SCREW	N.S.
4.	9788967-68	MLDG. PKG., Fender - Front	8.147		3-4531604	SPACER (Use with S/Steel)	10.096
	2-9777714	CLIP PKG.	8.148		3-4511999	SPACER (Use with Alum.)	10.096
5.	2-9787902	PLATE, "Tempest"	8.147	22.	4411952-53	SCALP, Frt. Door - Front	10.707
	6-9420621	NUT	8.148	23.	4430500-01	MOLDING, W/S - Side (S/Steel)	10.093
6.	2-9788966	MLDG. PKG., Fender - Rear	8.147		4492995-96	MOLDING, W/S - Side (Alum.)	10.093
	2-9777714	CLIP PKG.	8.148		8-4474354	CLIP (Use with S/Steel)	10.096
7.	4229714-15	MLDG. PKG., Frt. Door - Upr.	12.112		8-#8-18 x 3/4"	SCREW	N.S.
	2-9777697	CLIP PKG.	12.118		4-4531604	SPACER (Use with S/Steel)	10.096
8.	4229712-13	MLDG. PKG., Frt. Door - Lwr.	12.112		4-4511999	SPACER (Use with Alum.)	10.096
	2-9777697	CLIP PKG.	12.118	24.	4430502-03	MOLDING, W/S - Upper (S/Steel)	10.093
9.	9788949-50	MLDG. PKG., Rocker	8.304		4492998-99	MOLDING, W/S - Upper (Alum.)	10.093
	2-9777710	CLIP PKG.	8.309		8-4474354	CLIP (Use with S/Steel)	10.096
10.	4229706-07	MLDG. PKG., Rr. Door - Upr.	12.114		8-7698976	CLIP (Use with Alum.)	10.096
	2-9777694	CLIP PKG.	12.118		8-#8-18 x 3/4"	SCREW	N.S.
11.	4229708-09	MLDG. PKG., Rr. Door - Lwr.	12.114	25.	7582953-54	SCALP, Frt. Door - Upper	10.707
	2-9777695	CLIP PKG.	12.118	26.	4464155-56	SCALP, Frt. Door - Rear	10.707
12.	4229954-55	MLDG. PKG., On Lock Pillar - Painted	12.116	27.	4424798-99	MOLDING, Pillar	12.113
	6-#8-18 x 3/8"	SCREW	N.S.		4-#8-18 x 3/8"	SCREW	N.S.
13.	4229950	MLDG. PKG., L.H.-Qtr.-Frt.	12.116	28.	7603376-77	SCALP, Rr. Door - Front	10.772
	5-7674304	CLIP	12.118	29.	7582957-58	SCALP, Rr. Door - Upper	10.772
14.	4229952-53	MLDG. PKG. - Over W/House Opng.	12.116	30.	4430413-14	ESCUTCHEON, Qtr. Window	11.031
	16-7584569	CLIP	12.118	31.	4545618-19	SCALP, Rr. Door - Rear	10.772
15.	4229949	MLDG. PKG., Filler Door	12.116	32.	4541767-68	MOLDING, Qtr. Wind. - Lwr.	11.031
	1-9777706	CLIP PKG.	12.118		10-4474354	CLIP	11.032
16.	4227184-85	MLDG. PKG., Stone	12.116		10-#8-18 x 3/4"	SCREW	N.S.
	6-588546	SCREW	12.118		10-7600986	SPACER	11.032
17.	4229948	MLDG. PKG., L.H.Qtr. Upr. Rr.	12.116	33.	4430942-43	MOLDING, Qtr. Wind. - Upr.	11.031
	5-7674304	CLIP	12.118		8-4474354	CLIP	11.032
18.	4229946-47	MLDG. PKG., Qtr. Lwr. Rr.	12.116		8-#8-18 x 3/4"	SCREW	N.S.
	12-7674304	CLIP	12.118		10-7600986	SPACER	11.032
				34.	4229951	MLDG. PKG., R.H. - Qtr. Rear	12.116
					1-9777707	CLIP PKG.	12.118
				35.	4430413-14	ESCUTCHEON, Qtr. Window	11.031

WOOD GRAINED TRANSFER MATERIAL—FRONT FENDER—8.147

WOOD GRAINED TRANSFER MATERIAL—FRONT DOOR, REAR DOOR, REAR QUARTER, FUEL FILLER DOOR—10.354

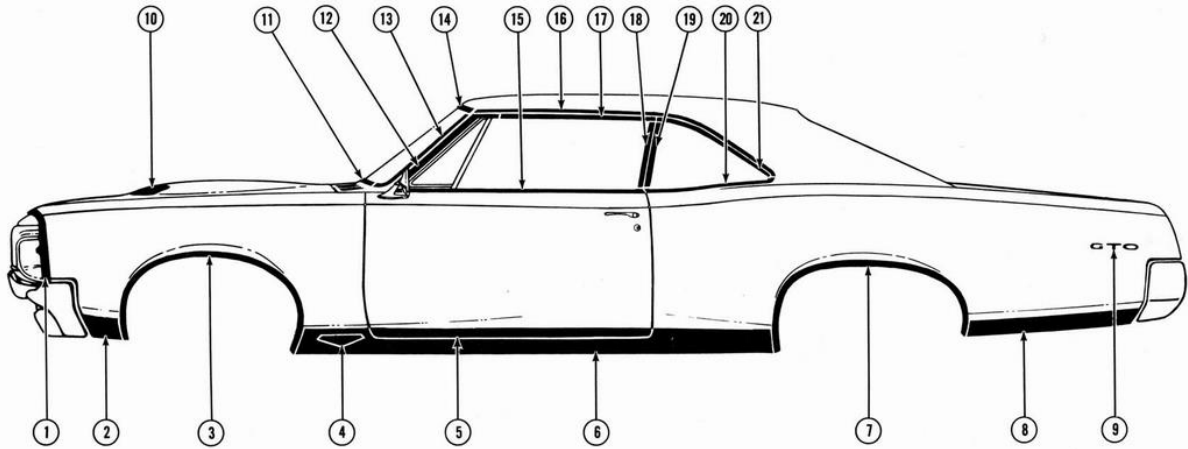

1967 G.T.O. 2-DOOR COUPE-4207

Key Qty.	Part No.	Name	Group No.	Key Qty.	Part No.	Name	Group No.
1.	9782752-53	BEZEL	2.728	11.	4430558	MOLDING, W/S - Lower.	10.093
	4-9414754	SCREW	8.977		7-4474354	CLIP	10.096
	4-9423737	SCREW	2.729		7-#8-18 x 3/4"	SCREW	N.S.
	4-380382	NUT	2.729		3-4531604	SPACER	10.096
	4-3863669	NUT	2.729	12.	4547690-91	SCALP, Door - Front	10.707
2.	9788957-58	MLDG. PKG., Fender - Lower	8.147	13.	4541650-51	MOLDING, W/S - Side.	10.093
	4-9420621	NUT	8.148		8-4474354	CLIP	10.096
3.	9785448-49	MLDG. PKG., W/Opening	8.147		8-#8-18 x 3/4"	SCREW	N.S.
	16-588546	SCREW	8.148		4-4531604	SPACER	10.096
4.	2-9775867	EMBLEM, "G.T.O."	8.304	14.	4541648-49	MOLDING, W/S - Upper.	10.093
	4-9420621	NUT	8.148		8-4474354	CLIP	10.096
5.	4229710-11	MLDG. PKG., Door	12.112		8-#8-18 x 3/4"	SCREW	N.S.
	2-9777696	CLIP PKG.	12.118	15.	7580768-69	MOLDING, Door - Window.	10.707
6.	9788955-56	MLDG. PKG., Rocker	8.304		8-#8-18 x 1/2"	SCREW	N.S.
	2-9777712	CLIP PKG.	8.309	16.	4547733-34	SCALP, Roof	12.075
7.	4227182-83	MLDG. PKG., W/Opening	12.116	17.	4547218-19	SCALP, Door - Upper	10.707
	14-588546	SCREW	12.118	18.	4544920-21	SCALP, Door - Rear	10.707
8.	4229729-30	MLDG. PKG. Rr. of W/Opng.	12.116	19.	7581320-21	MOLDING, Qtr. Wind. - Frt.	11.031
	2-9777698	CLIP PKG.	12.118	20.	7580595-96	MOLDING, Qtr. Window	11.031
9.	2-9775668	PLATE, "G.T.O."	12.116		6-#8-18 x 1/2"	SCREW	N.S.
	6-9419764	NUT	12.118	21.	4548436-37	MOLDING, Qtr. Wind. - Upr.	11.031
10.	9780159	ORNAMENT, Hood	8.030				
	3-273329	NUT	8.921				

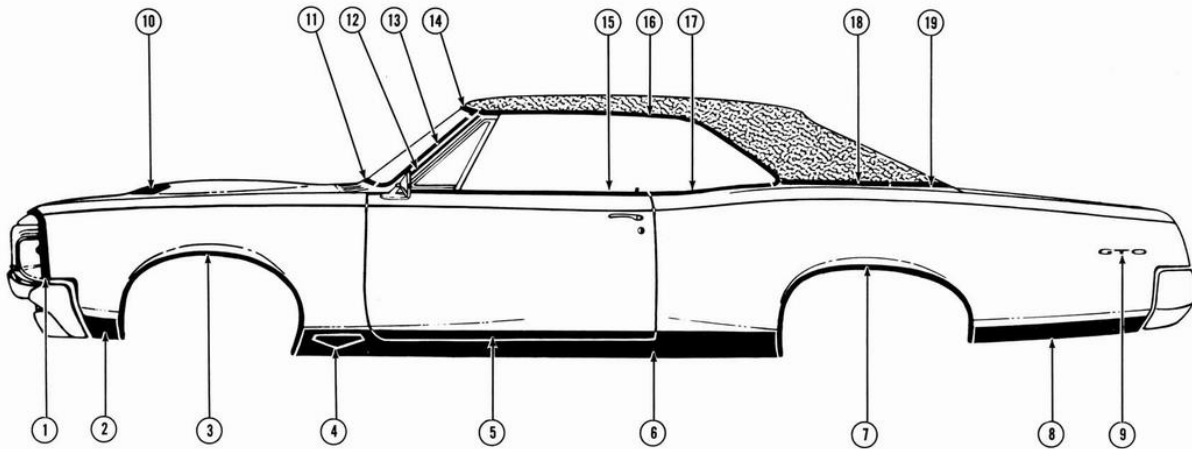

1967 G.T.O. 2-DOOR SPORT COUPE-4217 (W/CORDOVA TOP)

Key Qty.	Part No.	Name	Group No.	Key Qty.	Part No.	Name	Group No.
1.	9782752-53	BEZEL	2.728	11.	4430558	MOLDING, W/S - Lower	10.093
	4-9414754	SCREW	8.977		7-4474354	CLIP	10.096
	4-9423737	SCREW	2.729		7-#8-18 x 3/4"	SCREW	N.S.
	4-380382	NUT	2.729		3-4531604	SPACER	10.096
	4-3863669	NUT	2.729				
2.	9788957-58	MLDG. PKG., Fender - Lower	8.147	12.	4543090-91	MOLDING, Pillar - Finish	10.093
	4-9420621	NUT	8.148				
3.	9785448-49	MLDG. PKG., W/Opening	8.147	13.	4541650-51	MOLDING, W/S - Side	10.093
	16-588546	SCREW	8.148		8-4474354	CLIP	10.096
					8-#8-18 x 3/4"	SCREW	N.S.
					4-4531604	SPACER	10.096
4.	2-9775867	EMBLEM, "G.T.O."	8.304	14.	4541648-49	MOLDING, W/S - Upper	10.093
	4-9420621	NUT	8.148		8-4474354	CLIP	10.096
					8-#8-18 x 3/4"	SCREW	N.S.
5.	4229710-11	MLDG. PKG., Door	12.112	15.	7580770-71	MOLDING, Door - Window	10.707
	2-9777696	CLIP PKG.	12.118		8-#8-18 x 1/2"	SCREW	N.S.
6.	9788955-56	MLDG. PKG., Rocker	8.304	16.	4547733-34	SCALP, Roof	12.075
	2-9777712	CLIP PKG.	8.309				
				17.	7580593-94	MOLDING, Qtr. Window	11.031
7.	4227182-83	MLDG. PKG., W/Opening	12.116				
	14-588546	SCREW	12.118	18.	7589524-25	MOLDING, Belt - Outer	12.116
					8-7617597	CLIP	12.118
8.	4229729-30	MLDG. PKG., Rr. of W/Opng.	12.116				
	2-9777698	CLIP PKG.	12.118	19.	7589292-93	MOLDING, Belt - Inner	12.116
					4-4817162	CLIP	12.118
					4-7617597	CLIP	12.118
					4-9419763	NUT	12.118
10.	9780159	ORNAMENT, Hood	8.030				
	3-273329	NUT	8.921				

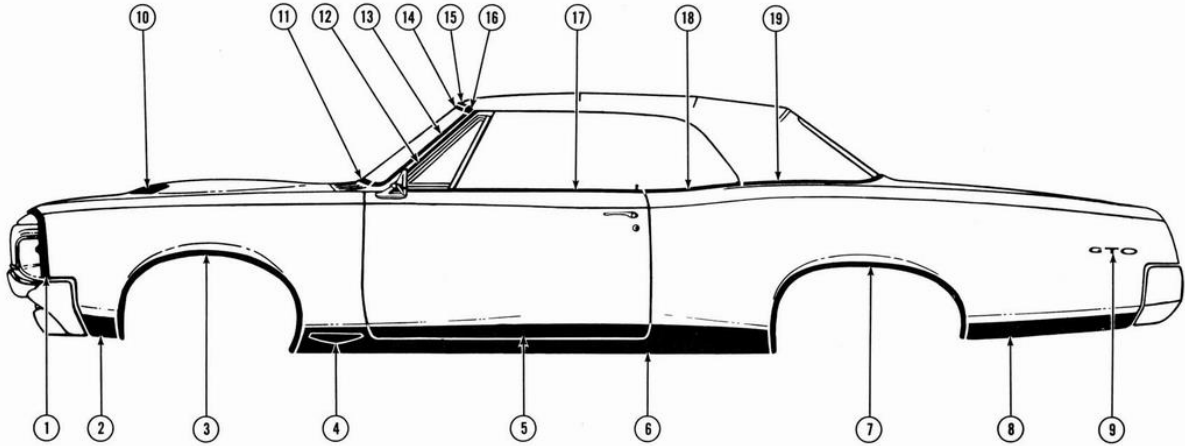

1967 G.T.O. CONVERTIBLE COUPE—4267

Key Qty.	Part No.	Name	Group No.	Key Qty.	Part No.	Name	Group No.
1.	9782752-53	BEZEL	2.728	11.	4430558	MOLDING, W/S - Lower	10.093
	4-9414754	SCREW	8.977		7-4474354	CLIP	10.096
	4-9423737	SCREW	2.729		7-#8-18 x 3/4"	SCREW	N.S.
	4-380382	NUT	2.729		3-4531604	SPACER	10.096
	4-3863669	NUT	2.729	12.	4543092-93	MOLDING, Pillar - Finish	10.093
2.	9788957-58	MLDG. PKG., Fender - Lower	8.147	13.	4541650-51	MOLDING, W/S - Side	10.093
	4-9420621	NUT	8.148		8-4474354	CLIP	10.096
3.	9785448-49	MLDG. PKG., W/Opening	8.147		8-#8-18 x 3/4"	SCREW	N.S.
	16-588546	SCREW	8.148		4-4531604	SPACER	10.096
4.	2-9775867	EMBLEM, "G.T.O."	8.304	14.	4541648-49	MOLDING, W/S - Upper	10.093
	4-9420621	NUT	8.148		8-4474354	CLIP	10.096
5.	4229710-11	MLDG. PKG., Door	12.112		8-#8-18 x 3/4"	SCREW	N.S.
	2-9777696	CLIP PKG.	12.118	15.	4542518	HEADER, Center	10.093
6.	9788955-56	MLDG. PKG., Rocker	8.304		4-4409925	SCREW	10.096
	2-9777712	CLIP PKG.	8.309	16.	4542516-17	HEADER, Side	10.093
7.	4227182-83	MLDG. PKG., W/Opening	12.116		2-4409925	SCREW	10.096
	14-588546	SCREW	12.118	17.	7582451-52	MOLDING, Door - Window	10.707
8.	4229729-30	MLDG. PKG., Rr. of W/Opng.	12.116		8-#8-18 x 1/2"	SCREW	N.S.
	2-9777698	CLIP PKG.	12.118	18.	4541660-61	MOLDING, Qtr. Window	11.031
9.	2-9775668	PLATE, "G.T.O."	12.116		6-#8-18 x 1/2"	SCREW	N.S.
	6-9419764	NUT	12.118	19.	4541666-67	MOLDING, Finish	12.116
10.	9780159	ORNAMENT, Hood	8.030		16-7584999	CLIP	12.118
	3-273329	NUT	8.921				

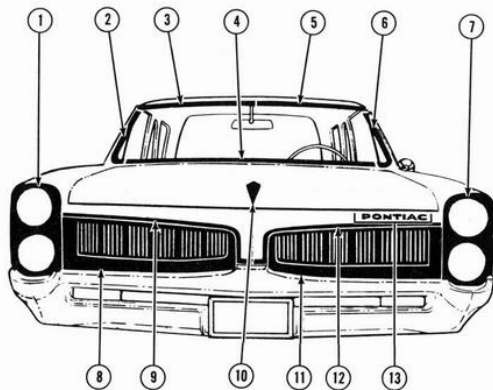

**1967 TEMPEST (33, 35, 37, 39 MODELS)
FRONT END VIEW
TYPICAL OF 35-39 & 69 STYLES**

Key	Qty.	Part No.	Name	Group No.
1.		9782752	BEZEL	2.728
	2-	9414754	SCREW	8.977
	2-	9423737	SCREW	2.729
	2-	380382	NUT	2.729
	2-	3863669	NUT	2.729
2.	*4430500	MOLDING, W/S - Side	10.093	
	*4-	4474354	CLIP	10.096
	4-	#8-18 x 3/4"	SCREW	N.S.
	*2-	4531604	SPACER	10.096
3.	*4430502	MOLDING, W/S - Upper	10.093	
	*4-	4474354	CLIP	10.096
	4-	#8-18 x 3/4"	SCREW	N.S.
4.	*4430558	MOLDING, W/S - Lower.	10.093	
	*7-	4474354	CLIP	10.096
	7-	#8-18 x 3/4"	SCREW	N.S.
	*3-	4531604	SPACER.	10.096
5.	*4430503	MOLDING, W/S - Upper.	10.093	
	*4-	4474354	CLIP	10.096
	4-	#8-18 x 3/4"	SCREW	N.S.
6.	*4430501	MOLDING, W/S - Side	10.093	
	*4-	4474354	CLIP	10.096
	4-	#8-18 x 3/4"	SCREW	N.S.
	*2-	4531604	SPACER.	10.096
7.	9782753	BEZEL	2.728	
	2-	9414754	SCREW	8.977
	2-	9423737	SCREW	2.729
	2-	380382	NUT	2.729
	2-	3863669	NUT	2.729
8.	9786916	GRILLE, R.H.	1.266	
9.	9787100	MOLDING, Grille - R.H.	1.268	
	5-	9420621	NUT.	1.303
10.	9783370	EMBLEM, Hood	8.055	
	2-	9420621	NUT	8.039
11.	9786917	GRILLE, L.H.	1.266	
12.	9787101	MOLDING, Grille - L.H.	1.268	
	5-	9420621	NUT	1.303
13.	1-	9787730	LETTER "P"	1.303
	1-	9787731	LETTER "O"	1.303
	1-	9787732	LETTER "N"	1.303
	1-	9787733	LETTER "T"	1.303
	1-	9787734	LETTER "I"	1.303
	1-	9787735	LETTER "A"	1.303
	1-	9787736	LETTER "C"	1.303
	7-	9419751	NUT	1.303

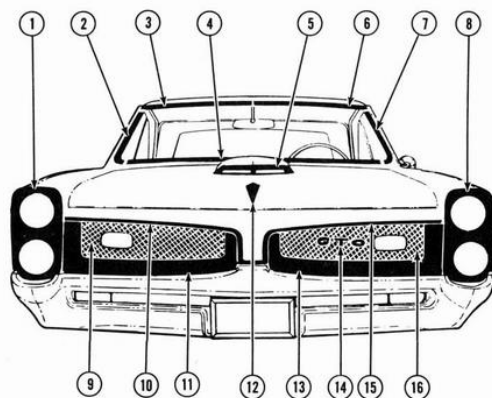

**1967 G.T.O. (42 MODELS)
FRONT END VIEW
TYPICAL OF 07-17 & 67 STYLES**

Key	Qty.	Part No.	Name	Group No.
1.		9782752	BEZEL	2.728
	2-	9414754	SCREW	8.977
	2-	9423737	SCREW	2.729
	2-	380382	NUT	2.729
	2-	3863669	NUT	2.729
2.	4541650	MOLDING, W/S - Side	10.093	
	4-	4474354	CLIP	10.096
	4-	#8-18 x 3/4"	SCREW	N.S.
	2-	4531604	SPACER	10.096
3.	4541648	MOLDING, W/S - Upper.	10.093	
	4-	4474354	CLIP	10.096
	4-	#8-18 x 3/4"	SCREW	N.S.
4.	4430558	MOLDING, W/S - Lower.	10.093	
	7-	4474354	CLIP	10.096
	7-	#8-18 x 3/4"	SCREW	N.S.
	3-	4531604	SPACER.	10.096
5.	9780159	ORNAMENT, Hood	8.030	
	3-	273329	NUT	8.039
6.	4541649	MOLDING, W/S - Upper	10.093	
	4-	4474354	CLIP	10.096
	4-	#8-18 x 3/4"	SCREW	N.S.
7.	4541651	MOLDING, W/S - Side	10.093	
	4-	4474354	CLIP	10.096
	4-	#8-18 x 3/4"	SCREW	N.S.
	2-	4531604	SPACER	10.096
8.	9782753	BEZEL	2.728	
	2-	9414754	SCREW	8.977
	2-	9423737	SCREW	2.728
	2-	380382	NUT	2.728
	2-	3863669	NUT	2.728
9.	9787759	GRILLE	1.266	
10.	9787100	MOLDING, Grille - R.H.	1.268	
	5-	9420621	NUT	1.303
11.	9787207	BEZEL, R.H.	1.266	
12.	9783370	EMBLEM, Hood	8.055	
	2-	9420621	NUT	8.039
13.	9787208	BEZEL, L.H.	1.266	
14.	9787967	PLATE, "G.T.O."	1.303	
	2-	9420621	NUT	1.303
15.	9787101	MOLDING, Grille - L.H.	1.268	
	5-	9420621	NUT	1.303
16.	9787759	GRILLE	1.266	

***NOTE: 1ST TYPE STAINLESS STEEL—SEE SIDE VIEWS FOR 2ND TYPE ALUMINUM MLDGS.**

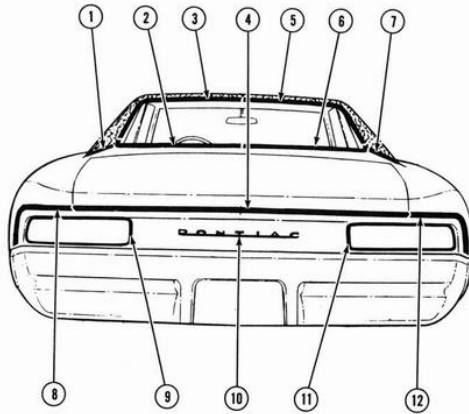

**1967 TEMPEST 2-DOOR COUPE
REAR END VIEW
TYPICAL OF 3307, 3507-17 STYLES**

Key	Qty.	Part No.	Name	Group No.
1.		7589293	MOLDING, Belt - Inner	12.116
	2-	4817162	CLIP	12.118
	2-	7594209	CLIP	12.118
	2-	9419763	NUT	12.118
2.		7581671	MOLDING, B/Wind. - Lower	11.208
	4-	7634583	CLIP	11.209
3.		7580181	MOLDING, B/Wind. - Upper.	11.208
	6-	7634583	11.209
4.		4229876	MLDG. PKG., Lid.	12.182
	1-	9777701	CLIP PKG.	12.183
5.		7580180	MOLDING, B/Wind. - Upper	11.208
	6-	7634583	CLIP	11.209
6.		7581670	MOLDING, B/Wind. - Lower	11.208
	4-	7634583	CLIP	11.209
7.		7589292	MOLDING, Belt - Inner	12.116
	2-	4817162	CLIP	12.118
	2-	7594209	CLIP	12.118
	2-	9419763	NUT	12.118
8.		4229874	MLDG. PKG., Rear	12.116
	1-	9777700	CLIP PKG.	12.118
9.		5959097	BEZEL, T/Lamp	2.681
10.		7667708	PLATE, "Pontiac".	12.182
	4-	4528566	NUT	12.183
11.		5959098	BEZEL, T/Lamp	2.681
12.		4229873	MLDG. PKG., Rear	12.116
	1-	9777700	CLIP PKG.	12.118

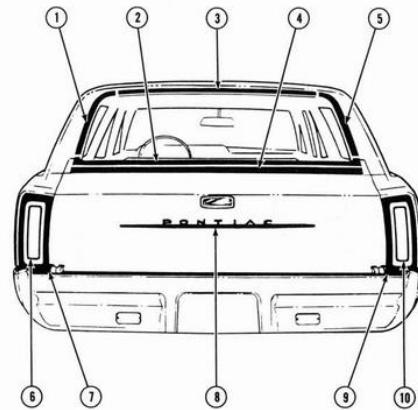

**1967 TEMPEST 4-DOOR STATION WAGON
REAR END VIEW
3335-3535**

Key	Qty.	Part No.	Name	Group No.
1.		4430495	MOLDING, Side	12.180
	3-	#8-18 x 1/4"	SCREW	N.S.
2.		7649781	MOLDING, Lower	12.180
	6-	4412822	CLIP	12.180
	2-	#8-18 x 3/8"	SCREW	N.S.
3.		4430498	MOLDING, Upper	12.180
	2-	#8-18 x 1/4"	SCREW	N.S.
4.		4227339	MLDG. PKG., Belt	12.180
	5-	4452339	WASHER	12.180
	5-	9419764	NUT	12.180
5.		4430494	MOLDING, Side	12.180
	3-	#8-18 x 1/4"	SCREW	N.S.
6.		5958731	BEZEL, T/Lamp	2.681
7.		7645193	EXT., At Lamp	12.940
	2-	1/4"-20 x 1-3/16"	SCREW	N.S.
	4-	3/8" I.D. x 3/4" O.D. x 1/32"	WASHER.	N.S.
	2-	5/16"-12	NUT W/WASHER	N.S.
8.		4229934	MLDG. PKG., "Pontiac"	12.180
	6-	9419763	NUT	12.180
9.		7645192	EXT., At Lamp	12.940
	2-	1/4"-20 x 1-3/16"	SCREW	N.S.
	4-	3/8" I.D. x 3/4" O.D. x 1/32"	WASHER.	N.S.
	2-	5/16"-12	NUT W/WASHER	N.S.
10.		5958732	BEZEL, T/Lamp	2.681

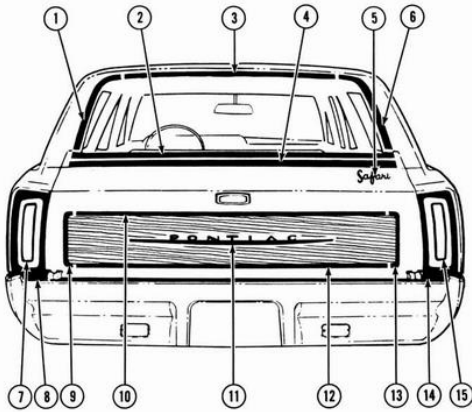

**1967 SAFARI 4-DOOR STATION WAGON
REAR END VIEW
3935**

Key	Qty.	Part No.	Name	Group No.
1.	4430495	MOLDING, Side	12.180	
	3-	#8-18 x 1/4" SCREW	N.S.	
2.	7649781	MOLDING, Lower	12.180	
	6-	4412822 CLIP	12.180	
	2-	#8-18 x 3/8" SCREW	N.S.	
3.	4430498	MOLDING, Upper	12.180	
	2-	#8-18 x 1/4" SCREW	N.S.	
4.	4227339	MLDG. PKG., Belt	12.180	
	5-	4452339 WASHER	12.180	
	5-	9419764 NUT	12.180	
5.	7694487	PLATE, "Safari"	12.180	
	2-	9419764 NUT	12.180	
6.	4430494	MOLDING, Side	12.180	
	3-	#8-18 x 1/4" SCREW	N.S.	
7.	5958731	BEZEL, T/Lamp	2.681	
8.	7645193	EXT., At Lamp	12.940	
	2-	1/4"-20 x 1-3/16" SCREW	N.S.	
	4-	3/8" I.D. x 3/4" O.D. x 1/32" WASHER	N.S.	
	2-	5/16"-12 NUT W/WASHER	N.S.	
9.	4229935	MLDG. PKG., Side	12.180	
	3-	9419764 NUT	12.180	
10.	4229933	MLDG. PKG., Upper	12.180	
	1-	9777705 CLIP PKG.	12.180	
11.	4229934	MLDG. PKG., "Pontiac"	12.180	
	6-	9419763 NUT	12.180	
12.	4229933	MLDG. PKG., Lower	12.180	
	1-	9777705 CLIP PKG.	12.180	
13.	4229935	MLDG. PKG., Side	12.180	
	3-	9419764 NUT	12.180	
14.	7645192	EXT., At Lamp	12.940	
	2-	1/4"-20 x 1-3/16" SCREW	N.S.	
	4-	3/8" I.D. x 3/4" O.D. x 1/32" WASHER	N.S.	
	2-	5/16"-12 NUT W/WASHER	N.S.	
15.	5958732	BEZEL, T/Lamp	2.681	

**WOOD GRAINED TRANSFER MATERIAL—
TAIL GATE—10.354**

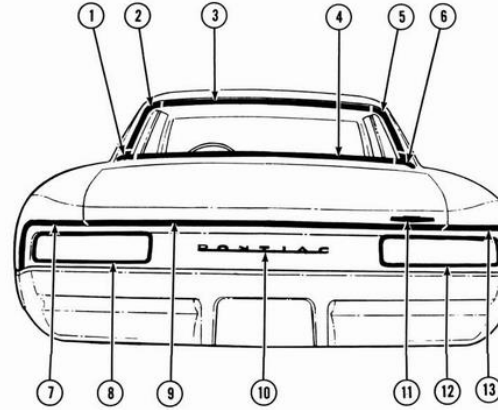

**1967 LE MANS 4-DOOR HARDTOP
REAR END VIEW
TYPICAL OF 39 STYLES (3739 SHOWN)**

Key	Qty.	Part No.	Name	Group No.
1.	7653746	ESCUT., B/Wind. - Lower	11.209	
	*7653748	ESCUT., B/Wind. - Lower	11.209	
	1-	4501682 WASHER	2.688	
	1-	9419766 NUT	8.921	
	1-	#8-18 x 3/8" SCREW	N.S.	
2.	4542271	MOLDING, B/Wind. - Side	11.208	
	4-	4474354 CLIP	11.209	
	1-	4531604 SPACER	11.209	
3.	4541890	MOLDING, B/Wind. - Upper	11.208	
	5-	4474354 CLIP	11.209	
	3-	4531604 SPACER	11.209	
4.	4542269	MOLDING, B/Wind. - Lower	11.208	
	7-	4474354 CLIP	11.209	
	3-	4531604 SPACER	11.209	
5.	4542270	MOLDING, B/Wind. - Side	11.208	
	4-	4474354 CLIP	11.209	
	1-	4531604 SPACER	11.209	
6.	7653745	ESCUT., B/Wind. - Lower	11.209	
	*7653747	ESCUT., B/Wind. - Lower	11.209	
	1-	4501682 WASHER	2.688	
	1-	9419766 NUT	8.921	
	1-	#8-18 x 3/8" SCREW	N.S.	
7.	4229874	MLDG. PKG., Rear	12.116	
	1-	9777700 CLIP PKG.	12.118	
8.	5959097	BEZEL, T/Lamp	2.681	
9.	4229876	MLDG. PKG., Lid	12.182	
	1-	9777701 CLIP PKG.	12.183	
10.	7667708	PLATE, "Pontiac"	12.182	
	4-	4528566 NUT	12.183	
11.	7681689	EMBLEM, Lid	12.182	
	2-	9419763 NUT	12.183	
12.	5959098	BEZEL, T/Lamp	2.681	
13.	4229873	MLDG. PKG., Rear	12.116	
	1-	9777700 CLIP PKG.	12.118	

***USE THESE PARTS WITH 2-TONE PAINT OR
CORDOVA TOP**

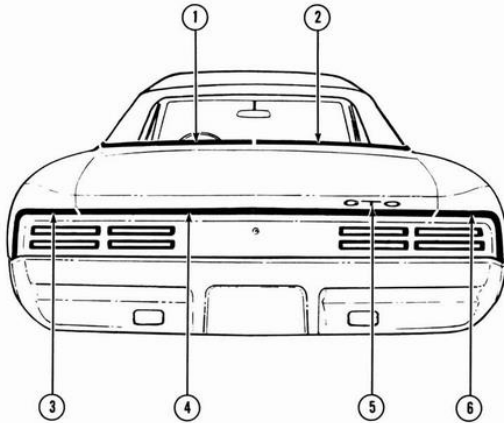

**1967 G.T.O. CONVERTIBLE COUPE
REAR END VIEW
TYPICAL OF 67 STYLES (4267 SHOWN)**

Key	Qty.	Part No.	Name	Group No.
1.		4541663	MOLDING, Finish (35)	12.116
		4541667	MOLDING, Finish (37 & 42)	12.116
		8-7584999	CLIP	12.118
2.		4541662	MOLDING, Finish (35)	12.116
		4541666	MOLDING, Finish (37 & 42)	12.116
		8-7584999	CLIP	12.118
3.		4229874	MLDG. PKG., Rear	12.116
		1-9777700	CLIP PKG.	12.118
4.		4229876	MLDG. PKG., Lid	12.182
		1-9777701	CLIP PKG.	12.183
5.		7667612	PLATE, "G.T.O."	12.182
		2-9419763	NUT	8.921
6.		4229873	MLDG. PKG., Rear	12.116
		1-9777700	CLIP PKG.	12.118

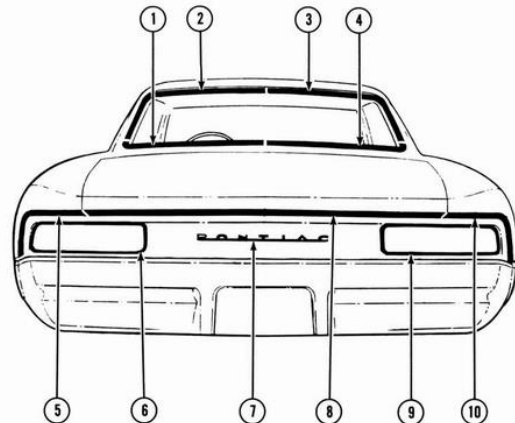

**1967 TEMPEST 4-DOOR SEDAN
REAR END VIEW
TYPICAL OF 69 STYLES (3369, 3569 SHOWN)**

Key	Qty.	Part No.	Name	Group No.
1.		4543026	MOLDING, B/Wind. - Lower	11.208
		4-4474354	CLIP	11.209
		2-4531604	SPACER	11.209
2.		4543011	MOLDING, B/Wind. - Side	11.208
		7-4474354	CLIP	11.209
		2-4531604	SPACER	11.209
3.		4543010	MOLDING, B/Wind. - Side	11.208
		7-4474354	CLIP	11.209
		2-4531604	SPACER	11.209
4.		4543025	MOLDING, B/Wind. - Lower	11.208
		4-4474354	CLIP	11.209
		2-4531604	SPACER	11.209
5.		4229874	MLDG. PKG., Rear	12.116
		1-9777700	CLIP PKG.	12.118
6.		5959097	BEZEL, T/Lamp	2.681
7.		7667708	PLATE, "Pontiac"	12.182
		4-4528566	NUT	12.183
8.		4229876	MLDG. PKG., Lid	12.182
		1-9777701	CLIP PKG.	12.183
9.		5959098	BEZEL, T/Lamp	2.681
10.		4229873	MLDG. PKG., Rear	12.116
		1-9777700	CLIP PKG.	12.118

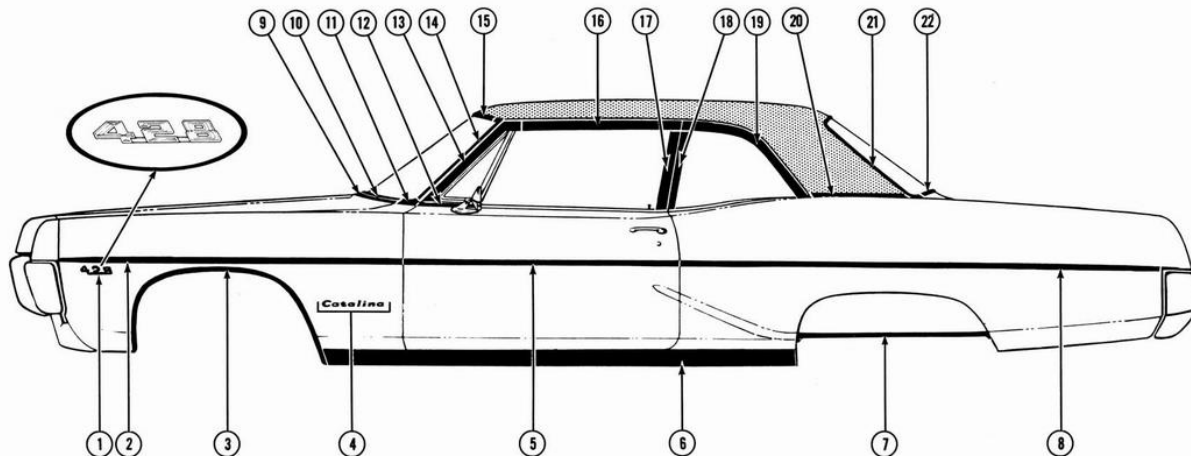

1967 CATALINA 2-DOOR SPORT SEDAN—5211 (428 ENGINE, 2-TONE PAINT & SKIRTS)

Key Qty.	Part No.	Name	Group No.	Key Qty.	Part No.	Name	Group No.
1.	9787948-49	EMBLEM, "428"	8.147	11.	9788959-60	MLDG. PKG., Fender - Rear	8.147
	6-9420621	NUT	8.148		2-9777676	SPACER	8.147
					4-9420621	NUT	8.148
2.	2-9788948	MLDG. PKG., Frt. Fender	8.147	12.	7653457-58	MOLDING, At Vent.	10.707
	2-9777709	CLIP PKG.	8.148				
3.	9788940-41	MLDG. PKG., W/Opening	8.147	13.	4482778-79	SCALP, Window - Front	10.707
	12-588546	SCREW	8.148				
4.	2-9787762	LETTER "C"	8.147	14.	7684971-72	MOLDING, W/S - Side	10.093
	6-9787773	LETTER "A"	8.147		8-7693140	CLIP	10.096
	2-9787768	LETTER "T"	8.147		6-4531604	SPACER	10.096
	2-9787771	LETTER "L"	8.147	15.	4467600	MOLDING, W/S - Upper	10.093
	2-9787769	LETTER "I"	8.147		7-7693140	CLIP	10.096
	2-9787772	LETTER "N"	8.147		7-4531604	SPACER	10.096
	16-9419751	NUT	8.148	16.	4483560-61	SCALP, Window - Upper	10.707
5.	2-4229518	MLDG. PKG., Door	12.112	17.	7648192-93	SCALP, Window - Rear	10.707
	2-9777682	CLIP PKG.	12.118	18.	7648557-58	SCALP, Qtr. Wind. - Front	11.031
6.	9788963-64	MLDG. PKG., Rocker	8.304	19.	7648555-56	SCALP, Qtr. Window - Upper	11.031
	2-9777708	CLIP PKG.	8.309		6-7715902	CLIP	11.032
7.	9788932-33	MLDG. PKG., Skirt	8.176	20.	7653296-97	MOLDING, Belt	12.116
	2-9789946	CLIP PKG.	8.176		6-7587044	CLIP	12.118
					2-7669865	CLIP	12.118
8.	2-4229895	MLDG. PKG., Qtr. Panel	12.116	21.	7648027-28	MLDG., B/Wind. - Upr. & Side	11.208
	2-9777704	CLIP PKG.	12.118		14-7693140	CLIP	11.209
9.	9787059	MOLDING, Hood	8.054		7-7660796	SPACER	11.209
10.	7657434	MOLDING, W/S - Lower	10.093	22.	7646796-97	MOLDING, B/Wind. - Lower	11.208
	8-#8-18 x 3/8"	SCREW	N.S.		8-7693140	CLIP	11.209
					3-7660796	SPACER	11.209

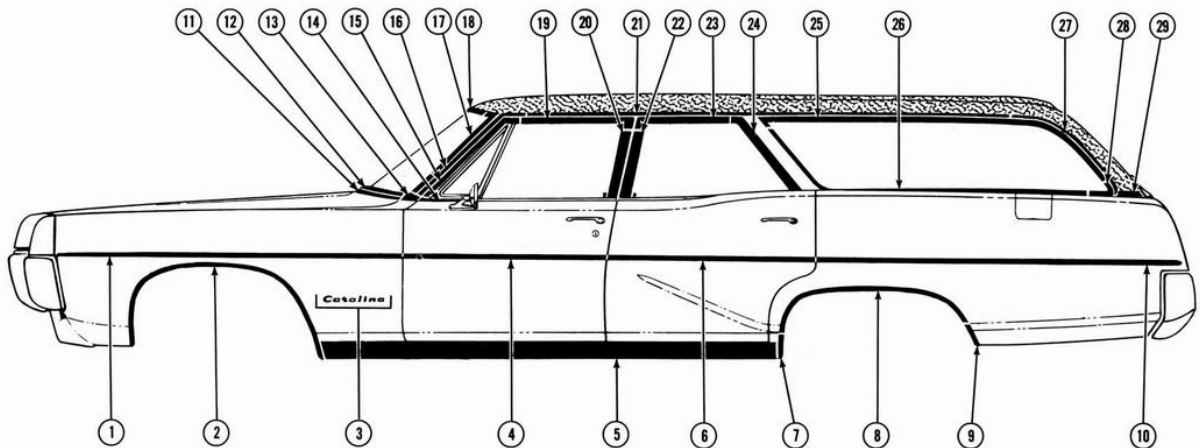

1967 CATALINA STATION WAGON—5235-45 (W/CORDOVA TOP)

Key Qty.	Part No.	Name	Group No.	Key Qty.	Part No.	Name	Group No.
1.	2-9788948	MLDG. PKG., Frt. Fender . . .	8.147	15.	4482778-79	SCALP, Frt. Door - Front . . .	10.707
	2-9777709	CLIP PKG.	8.148	16.	7685044-45	SCALP, Pillar - Drip	12.075
					8-#8-18 x 3/8"	SCREW	N.S.
2.	9788940-41	MLDG. PKG., W/Opening	8.147	17.	7684971-72	MOLDING, W/S - Side	10.093
	12-588546	SCREW	8.148		8-7693140	CLIP	10.096
					6-4531604	SPACER	10.096
3.	2-9787762	LETTER "C"	8.147	18.	4467600	MOLDING, W/S - Upper	10.093
	6-9787773	LETTER "A"	8.147		7-7693140	CLIP	10.096
	2-9787768	LETTER "T"	8.147		7-4531604	SPACER	10.096
	2-9787771	LETTER "L"	8.147	19.	7629776-77	SCALP, Frt. Door - Upper	10.707
	2-9787769	LETTER "I"	8.147	20.	4482060-61	SCALP, Frt. Door - Rear	10.707
	2-9787772	LETTER "N"	8.147	21.	4468346-47	SCALP, Roof - Front	12.075
	16-9419751	NUT.	8.148	22.	7646876-77	SCALP, Rr. Door - Front	10.772
4.	4229516-17	MLDG. PKG., Frt. Door	12.112	23.	7663380-81	SCALP, Rr. Door - Upper	10.772
	2-9777682	CLIP PKG.	12.118	24.	7648198-99	SCALP, Rr. Door - Rear	10.772
5.	9788963-64	MLDG. PKG., Rocker	8.304	25.	7639450-51	MOLDING, Qtr. Wind. - Upr.	11.031
	2-9777708	CLIP PKG.	8.309		14-7639528	CLIP.	11.032
					2-4501000	CLIP.	11.032
6.	4229514-15	MLDG. PKG., Rr. Door	12.114		2-#8-18 x 3/8"	SCREW	N.S.
	2-9777682	CLIP PKG.	12.118		10-4531604	SPACER	11.031
7.	9788930-31	MLDG. PKG., W/Opng. - Frt.	12.116	26.	7639392-93	MOLDING, Qtr. Wind. - Lwr.	11.031
	4-588546	SCREW.	12.118		12-4474354	CLIP.	11.032
					6-4501000	CLIP.	11.032
8.	9788944-45	MLDG. PKG., W/Opng. - Top	12.116		6-#8-18 x 3/8"	SCREW	N.S.
	14-588546	SCREW	12.118		10-4531604	SPACER	11.031
9.	9788942-43	MLDG. PKG., W/Opng. - Rr.	12.116	27.	4468436-37	SCALP, Roof - Rear	12.075
	4-588546	SCREW.	12.118	28.	2-7647286	ESCUTCHEON, Qtr. Window	11.031
10.	2-4229897	MLDG. PKG., Qtr. Panel	12.116	29.	3914082-81	MLDG. PKG., Belt	12.180
	2-9777703	CLIP PKG.	12.118		4-7656440	CLIP	12.180
					2-#8-18 x 3/8"	SCREW	N.S.
11.	9787059	MOLDING, Hood	8.054				
12.	7657434	MOLDING, W/S - Lower	10.093				
	8-#8-18 x 3/8"	SCREW	N.S.				
13.	9788959-60	MLDG. PKG., Fender - Rear	8.147				
	2-9777676	SPACER	8.147				
	4-9420621	NUT	8.148				
14.	7653457-58	MOLDING, At Vent	10.707				

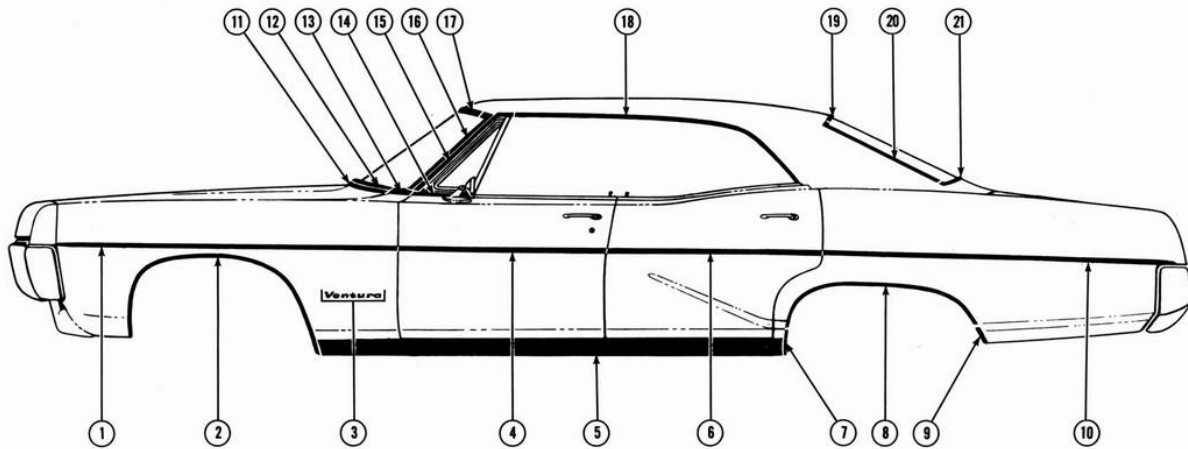

1967 CATALINA 4-DOOR HARDTOP-5239 (W/VENTURA OPTION)

Key Qty.	Part No.	Name	Group No.	Key Qty.	Part No.	Name	Group No.
1.	2-9788948 MLDG. PKG., Frt. Fender . . .		8.147	11.	9787059 MOLDING, Hood		8.054
	2-9777709 CLIP PKG.		8.148	12.	7657434 MOLDING, W/S - Lower		10.093
					8-#8-18 x 3/8" SCREW		N.S.
2.	9788940-41 MLDG. PKG., W/Opening . . .		8.147	13.	9788959-60 MLDG. PKG., Fender - Rear . .		8.147
	12-588546 SCREW		8.148		2-9777676 SPACER		8.147
					4-9420621 NUT		8.148
3.	2-9787763 LETTER "V"		8.147	14.	7653453-54 MOLDING, At Vent		10.707
	2-9787765 LETTER "E"		8.147		4-#8-18 x 3/8" SCREW		N.S.
	2-9787772 LETTER "N"		8.147	15.	7670128-29 SCALP, Pillar - Drip		12.075
	2-9787768 LETTER "T"		8.147		8-#8-18 x 3/8" SCREW		N.S.
	2-9787767 LETTER "U"		8.147	16.	7684973-74 MOLDING, W/S - Side.		10.093
	2-9787774 LETTER "R"		8.147		8-7693140 CLIP		10.096
	2-9787773 LETTER "A"		8.147		6-4531604 SPACER		10.096
	14-9419751 NUT.		8.148	17.	4467604 MOLDING, W/S - Upper		10.093
4.	4229516-17 MLDG. PKG., Frt. Door		12.112		7-7693140 CLIP		10.096
	2-9777682 CLIP PKG.		12.118		7-4531604 SPACER.		10.096
5.	9788963-64 MLDG. PKG., Rocker		8.304	18.	7647431-32 SCALP, Roof		12.075
	2-9777708 CLIP PKG.		8.309	19.	7648026 MOLDING, B/Wind. - Upper . . .		11.208
6.	4229514-15 MLDG. PKG., Rr. Door		12.114		6-7693140 CLIP		11.209
	2-9777682 CLIP PKG.		12.118		3-7660796 SPACER		11.209
7.	9788930-31 MLDG. PKG., W/Opng. - Frt. .		12.116	20.	7649794-95 MOLDING, B/Wind. - Side. . .		11.208
	4-588546 SCREW.		12.118		6-7693140 CLIP		11.209
8.	9788944-45 MLDG. PKG., W/Opng. - Top .		12.116		4-7660796 SPACER		11.209
	14-588546 SCREW		12.118	21.	7648030-31 MOLDING, B/Wind. - Lower . .		11.208
9.	9788946-47 MLDG. PKG., W/Opng. - Rear.		12.116		8-7693140 CLIP		11.209
	4-588546 SCREW.		12.118		2-7660796 SPACER		11.209
10.	2-4229896 MLDG. PKG., Qtr. Panel		12.116				
	2-9777703 CLIP PKG.		12.118				

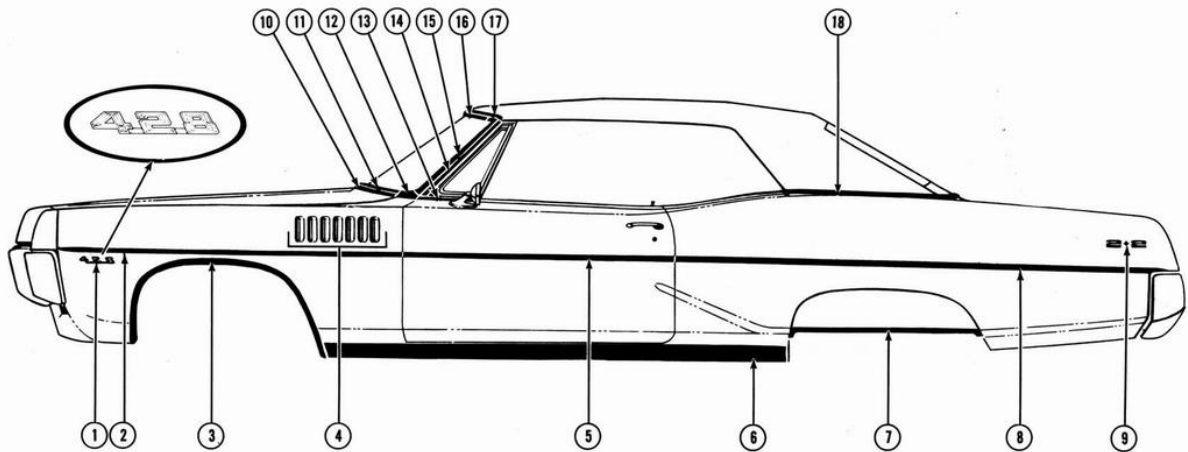

1967 CATALINA CONVERTIBLE COUPE—5267 (W/2+2 OPTION & SKIRTS)

Key Qty.	Part No.	Name	Group No.	Key Qty.	Part No.	Name	Group No.
1.	9787948-49	EMBLEM, "428"	8.147	11.	7657434	MOLDING, W/S - Lower	10.093
	6-9420621	NUT	8.148		8-#8-18 x 3/8"	SCREW	N.S.
2.	2-9788948	MLDG. PKG., Frt. Fender	8.147	12.	9788969-70	MLDG. PKG., Fender - Rear	8.147
	2-9777709	CLIP PKG.	8.148		2-9777676	SPACER.	8.147
					4-9420621	NUT	8.148
3.	9788940-41	MLDG. PKG., W/Opening	8.147	13.	7653453-54	MOLDING, At Vent	10.707
	12-588546	SCREW	8.148		4-#8-18 x 3/8"	SCREW	N.S.
4.	7-9788115-16	ORNAMENT, Louver	8.147	14.	7600994-95	MOLDING, Pillar - Finish	10.093
	28-9419751	NUT	8.148		10-#8-18 x 3/8"	SCREW	N.S.
					2-#8-18 x 3/8"	HEX. SCREW	N.S.
					2-4409925	SCREW	10.096
5.	2-4229518	MLDG. PKG., Door	12.112	15.	7684973-74	MOLDING, W/S - Side	10.093
	2-9777682	CLIP PKG.	12.118		8-7693140	CLIP	10.096
					6-4531604	SPACER.	10.096
6.	9788963-64	MLDG. PKG., Rocker	8.304	16.	4467604	MOLDING, W/S - Upper	10.093
	2-9777708	CLIP PKG.	8.309		7-7693140	CLIP	10.096
					7-4531604	SPACER.	10.096
7.	9788932-33	MLDG. PKG., Skirt	8.176	17.	7584209	HEADER	10.093
	2-9789946	CLIP PKG.	8.176		4-#8-18 x 1/2"	SCREW	N.S.
					4-#8-18 x 3/8"	SCREW	N.S.
8.	2-4229895	MLDG. PKG., Qtr. Panel	12.116	18.	3917770-69	MLDG. PKG., Finish	12.116
	2-9777704	CLIP PKG.	12.118		12-7672609	CLIP.	12.118
9.	2-7663983	PLATE, "2+2"	12.116		5-#8-18 x 1/4"	SCREW	N.S.
	4-3/32" I.D. x 13/64" O.D. x 1/16"						
		WASHER	N.S.				
	4-9419763	NUT	12.118				
10.	9787059	MOLDING, Hood	8.054				

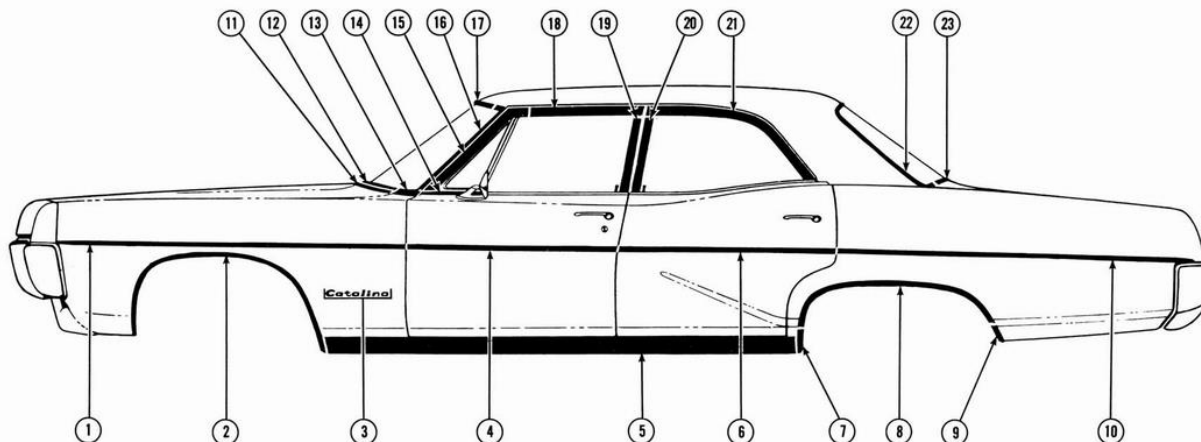

1967 CATALINA 4-DOOR SEDAN-5269

Key Qty.	Part No.	Name	Group No.	Key Qty.	Part No.	Name	Group No.
1.	2-9788948	MLDG. PKG., Frt. Fender . . .	8.147	12.	7657434	MOLDING, W/S - Lower	10.093
	2-9777709	CLIP PKG.	8.148		8-#8-18 x 3/8"	SCREW	N.S.
2.	9788940-41	MLDG. PKG., W/Opening . . .	8.147	13.	9788959-60	MLDG. PKG., Fender - Rear . .	8.147
	12-588546	SCREW	8.148		2-9777676	SPACER	8.147
3.	2-9787762	LETTER "C"	8.147		4-9420621	NUT	8.148
	6-9787773	LETTER "A"	8.147	14.	7653457-58	MOLDING, At Vent	10.707
	2-9787768	LETTER "T"	8.147	15.	4482778-79	SCALP, Frt. Door - Front	10.707
	2-9787771	LETTER "L"	8.147	16.	7684971-72	MOLDING, W/S - Side	10.093
	2-9787769	LETTER "I"	8.147		8-7693140	CLIP	10.096
	2-9787772	LETTER "N"	8.147		6-4531604	SPACER	10.096
	16-9419751	NUT.	8.148	17.	4467600	MOLDING, W/S - Upper	10.093
4.	4229516-17	MLDG. PKG., Frt. Door	12.112		7-7693140	CLIP	10.096
	2-9777682	CLIP PKG.	12.118		7-4531604	SPACER	10.096
5.	9788963-64	MLDG. PKG., Rocker	8.304	18.	7629776-77	SCALP, Frt. Door - Upper . . .	10.707
	2-9777708	CLIP PKG.	8.309	19.	4482060-61	SCALP, Frt. Door - Rear	10.707
6.	4229514-15	MLDG. PKG., Rr. Door	12.114	20.	7646876-77	SCALP, Rr. Door - Front	10.772
	2-9777682	CLIP PKG.	12.118	21.	7646845-46	SCALP, Rr. Door - Upper . . .	10.772
7.	9788930-31	MLDG. PKG., W/Opng. - Frt..	12.116	22.	7648027-28	MLDG., B/Wind. Upr. & Side .	11.208
	4-588546	SCREW.	12.118		14-7693140	CLIP.	11.209
8.	9788944-45	MLDG. PKG., W/Opng. - Top .	12.116		7-7660796	SPACER	11.209
	14-588546	SCREW	12.118	23.	7646796-97	MOLDING, Lower	11.208
9.	9788946-47	MLDG. PKG., W/Opng. - Rr. .	12.116		8-7693140	CLIP	11.209
	4-588546	SCREW.	12.118		3-7660796	SPACER	11.209
10.	2-4229896	MLDG. PKG., Qtr. Panel	12.116				
	2-9777703	CLIP PKG.	12.118				
11.	9787059	MOLDING, Hood	8.054				

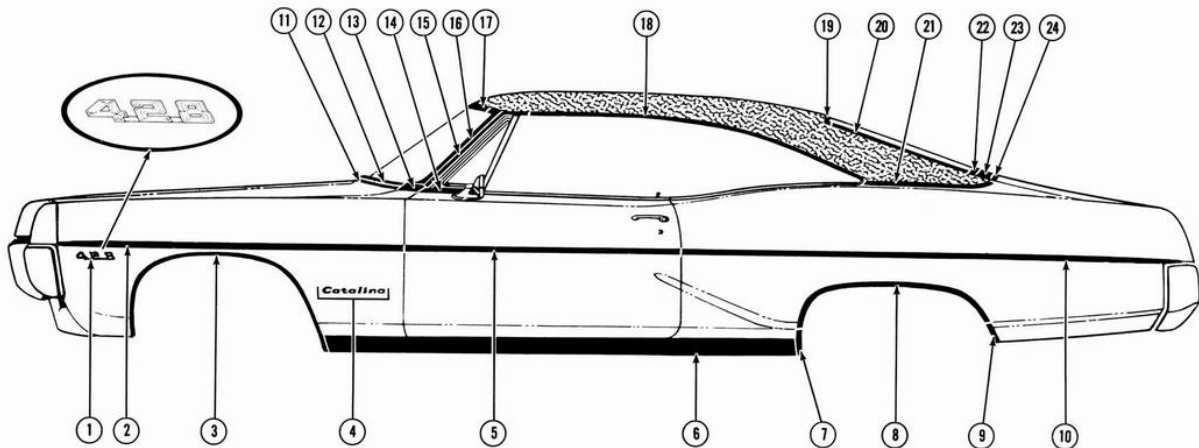

1967 CATALINA 2-DOOR SPORT COUPE-5287 (428 ENGINE & CORDOVA TOP)

Key Qty.	Part No.	Name	Group No.	Key Qty.	Part No.	Name	Group No.
1.	9787948-49	EMBLEM, "428"	8.147	14.	7653453-54	MOLDING, At Vent	10.707
	6-9420621	NUT	8.148		4-#8-18 x 3/8"	SCREW	N.S.
2.	2-9788948	MLDG. PKG., Frt. Fender	8.147	15.	7670128-29	SCALP, Pillar - Drip	12.075
	2-9777709	CLIP PKG.	8.148		8-#8-18 x 3/8"	SCREW	N.S.
3.	9788940-41	MLDG. PKG., W/Opening	8.147	16.	7684973-74	MOLDING, W/S - Side	10.093
	12-588546	SCREW	8.148		8-7693140	CLIP	10.096
4.	2-9787762	LETTER "C"	8.147		6-4531604	SPACER	10.096
	6-9787773	LETTER "A"	8.147	17.	4467604	MOLDING, W/S - Upper	10.093
	2-9787768	LETTER "T"	8.147		7-7693140	CLIP	10.096
	2-9787771	LETTER "L"	8.147		7-4531604	SPACER	10.096
	2-9787769	LETTER "I"	8.147	18.	7650002-03	SCALP, Roof	12.075
	2-9787772	LETTER "N"	8.147	19.	7646717-18	MOLDING, B/Wind. - Upper	11.208
	16-9419751	NUT	8.148		10-7639528	CLIP	11.209
5.	2-4229518	MLDG. PKG., Door	12.112		3-7660796	SPACER	11.209
	2-9777682	CLIP PKG.	12.118	20.	7647558-59	MOLDING, B/Wind. - Side	11.208
6.	9788963-64	MLDG. PKG., Rocker	8.304		8-7639528	CLIP	11.209
	2-9777708	CLIP PKG.	8.309		4-7660796	SPACER	11.209
7.	9788930-31	MLDG. PKG., W/Opng. - Frt.	12.116	21.	7649284-85	MOLDING, Belt	12.116
	4-588546	SCREW	12.118		6-7731589	CLIP	12.118
8.	9788944-45	MLDG. PKG., W/Opng. - Top	12.116		2-7669079	CLIP	12.118
	14-588546	SCREW	12.118		2-9419764	NUT	12.118
9.	9788946-47	MLDG. PKG., W/Opng. - Rr.	12.116	22.	7660862	MOLDING, B/Wind. - Lower	11.208
	4-588546	SCREW	12.118		8-7639528	CLIP	11.209
10.	2-4229895	MLDG. PKG., Qtr. Panel	12.116		8-7664118	SPACER	11.209
	2-9777704	CLIP PKG.	12.118	23.	4229644	MLDG. PKG., Compt. Lid - Painted	12.182
11.	9787059	MOLDING, Hood	8.054		1-9777689	CLIP PKG.	12.183
12.	7657434	MOLDING, W/S - Lower	10.093	24.	4229643	MLDG. PKG., Belt	12.182
	8-#8-18 x 3/8"	SCREW	N.S.		1-9777688	CLIP PKG.	12.183
13.	9788959-60	MLDG. PKG., Fender - Rear	8.147				
	2-9777676	SPACER	8.147				
	4-9420621	NUT	8.148				

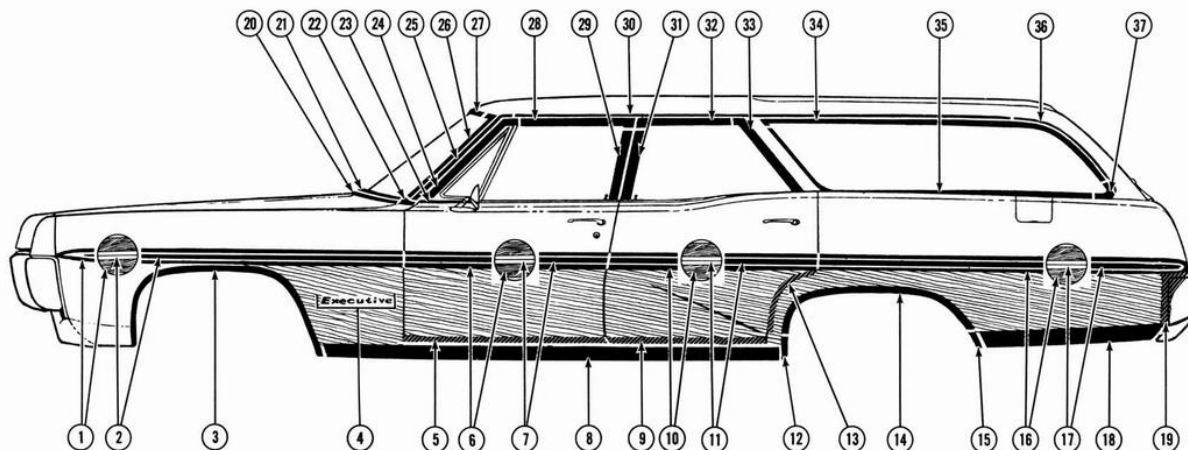

1967 EXECUTIVE SAFARI STATION WAGON—5635-45

Key Qty.	Part No.	Name	Group No.	Key Qty.	Part No.	Name	Group No.
1.	9788961-62	MLDG. PKG., Frt. Fender (Sim. Wood)	8.147	17.	2-4229679	MLDG. PKG., Qtr. Panel (Chrome)	12.116
	2-9777713	CLIP PKG.	8.148		10-7657720	CLIP	12.118
2.	2-9789173	MLDG. PKG., Frt. Fndr. (Chrome)	8.147	18.	4229684-85	MLDG. PKG., Rr. of W/Opng.	12.116
	2-9777713	CLIP PKG.	8.148		2-9777693	CLIP PKG.	12.118
3.	9788940-41	MLDG. PKG., W/Opening	8.147	19.	4229677-78	MLDG. PKG., Finish - Behind Bumper (Painted)	12.116
	12-588546	SCREW	8.148		8-#8-18 x 3/8"	SCREW	N.S.
4.	2-9787761	LETTER "E" (Cap)	8.147	20.	9787059	MOLDING, Hood	8.054
	2-9787764	LETTER "X"	8.147	21.	7657434	MOLDING, W/S - Lower	10.093
	4-9787765	LETTER "E" (Small)	8.147		8-#8-18 x 3/8"	SCREW	N.S.
	2-9787766	LETTER "C"	8.147	22.	9788959-60	MLDG. PKG., Fender - Rear	8.147
	2-9787767	LETTER "U"	8.147		2-9777676	SPACER	8.147
	2-9787768	LETTER "T"	8.147		4-9420621	NUT	8.148
	2-9787769	LETTER "I"	8.147	23.	7653457-58	MOLDING, At Vent	10.707
	2-9787770	LETTER "V"	8.147	24.	4482778-79	SCALP, Frt. Door - Front	10.707
	18-9419751	NUT	8.148	25.	7685044-45	SCALP, Pillar - Drip	12.075
5.	4229478-79	MLDG. PKG., Finish - Frt. Door (Painted)	12.112		8-#8-18 x 3/8"	SCREW	N.S.
	12-4403686	SCREW	11.128	26.	7684971-72	MOLDING, W/S - Side	10.093
6.	7694580-81	MLDG., Upr. - Frt. Door (Sim. Wood)	12.112		8-7693140	CLIP	10.096
7.	4229482-83	MLDG. PKG., Frt. Dr. (Chrome)	12.112		6-4531604	SPACER	10.096
	2-9777680	CLIP PKG.	12.118	27.	4467600	MOLDING, W/S - Upper	10.093
8.	9788963-64	MLDG. PKG., Rocker	8.304		7-7693140	CLIP	10.096
	2-9777708	CLIP PKG.	8.309		7-4531604	SPACER	10.096
9.	2-4229477	MLDG. PKG., Fin. - Rr. Dr. (Painted)	12.114	28.	7629776-77	SCALP, Frt. Door - Upper	10.707
	8-4403686	SCREW	11.128	29.	4482060-61	SCALP, Frt. Door - Rear	10.707
10.	7694582-83	MLDG., Upr - Rr. Dr. (Sim. Wood)	12.114	30.	4468346-47	SCALP, Roof - Front	12.075
11.	4229480-81	MLDG. PKG., Rr. Dr. (Chrome)	12.114	31.	7646876-77	SCALP, Rr. Door - Front	10.772
	2-9777680	CLIP PKG.	12.118	32.	7663380-81	SCALP, Rr. Door - Upper	10.772
12.	9788930-31	MLDG. PKG., W/Opng. - Frt.	12.116	33.	7648198-99	SCALP, Rr. Door - Rear	10.772
	4-588546	SCREW	12.118	34.	7639450-51	MOLDING, Qtr. Wind. - Upr.	11.031
13.	4229682-83	MLDG. PKG., On Lock Pillar (Painted)	12.116		14-7693140	CLIP	11.032
	12-#8 x 18 x 3/8"	SCREW	N.S.		2-4501000	CLIP	11.032
14.	9788944-45	MLDG. PKG., W/Opng. - Top	12.116		2-#8-18 x 3/8"	SCREW	N.S.
	14-588546	SCREW	12.118		10-4531604	SPACER	11.032
15.	9788942-43	MLDG. PKG., W/Opng. - Rr.	12.116	35.	7639392-93	MOLDING, Qtr. Wind. - Lwr.	11.031
	4-588546	SCREW	12.118		12-7693140	CLIP	11.032
16.	4229680-81	MLDG. PKG., Finish - Qtr. Panel (Sim. Wood)	12.116		6-4501000	CLIP	11.032
	18-#8 x 18 x 3/8"	SCREW	N.S.		6-#8-18 x 3/8"	SCREW	N.S.
					10-4531604	SPACER	11.032
				36.	7646851-52	SCALP, Roof - Rear	12.075
				37.	2-7647286	ESCUTCHEON, Qtr. Window	11.031

WOOD GRAINED TRANSFER MATERIAL—FRONT FENDER—8.147

WOOD GRAINED TRANSFER MATERIAL—FRONT DOOR, REAR DOOR, REAR QUARTER—10.354

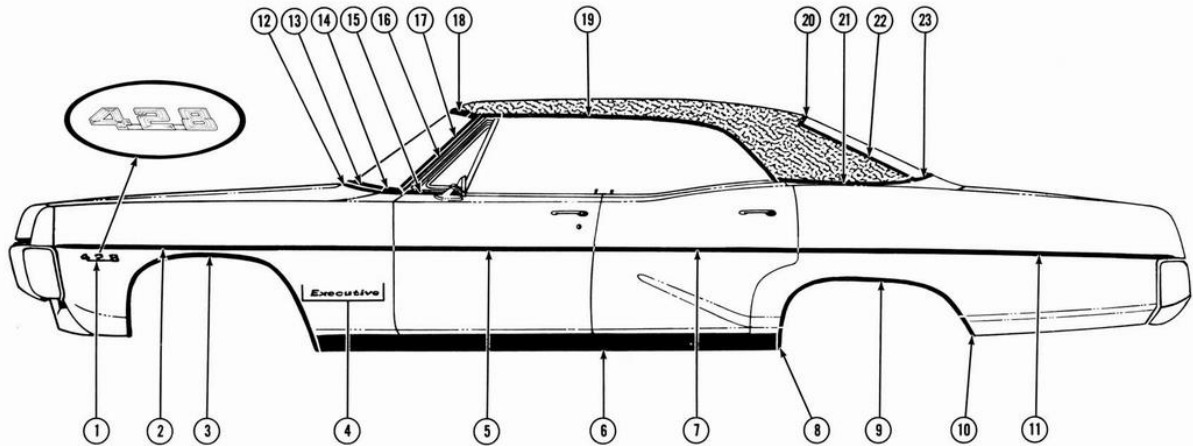

1967 EXECUTIVE 4-DOOR HARDTOP—5639 (428 ENGINE & CORDOVA TOP)

Key Qty.	Part No.	Name	Group No.	Key Qty.	Part No.	Name	Group No.
1.	9787948-49	EMBLEM, "428"	8.147	12.	9787059	MOLDING, Hood	8.054
	6-9420621	NUT	8.148	13.	7657434	MOLDING, W/S - Lower	10.093
2.	2-9788948	MLDG. PKG., Frt. Fender	8.147		8-#8-18 x 3/8"	SCREW	N.S.
	2-9777709	CLIP PKG.	8.148	14.	9788959-60	MLDG. PKG., Fender - Rear	8.147
3.	9788940-41	MLDG. PKG., W/Opening	8.147		2-9777676	SPACER	8.147
	12-588546	SCREW	8.148		4-9420621	NUT	8.148
4.	2-9787761	LETTER "E" (Cap)	8.147	15.	7653453-54	MOLDING, At Vent.	10.707
	2-9787764	LETTER "X"	8.147		4-#8-18 x 3/8"	SCREW	N.S.
	4-9787765	LETTER "E" (Small)	8.147	16.	7670128-29	SCALP, Pillar - Drip	12.075
	2-9787766	LETTER "C"	8.147		8-#8-18 x 3/8"	SCREW	N.S.
	2-9787767	LETTER "U"	8.147	17.	7684973-74	MOLDING, W/S - Side	10.093
	2-9787768	LETTER "T"	8.147		8-7693140	CLIP	10.096
	2-9787769	LETTER "I"	8.147		6-4531604	SPACER	10.096
	2-9787770	LETTER "V"	8.147	18.	4467604	MOLDING, W/S - Upper	10.093
	18-9419751	NUT.	8.148		7-7693140	CLIP	10.096
5.	4229516-17	MLDG. PKG., Frt. Door	12.112		7-4531604	SPACER	10.096
	2-9777682	CLIP PKG.	12.118	19.	7647431-32	SCALP, Roof	12.075
6.	9789537-38	MLDG. PKG., Rocker	8.304	20.	7648026	MOLDING, B/Wind. - Upper	11.208
	2-9777708	CLIP PKG.	8.309		6-7693140	CLIP	11.209
7.	4229514-15	MLDG. PKG., Rr. Door	12.114		3-7660796	SPACER.	11.209
	2-9777682	CLIP PKG.	12.118	21.	7653298-99	MOLDING, Belt.	12.116
8.	9788930-31	MLDG. PKG., W/Opng. - Frt.	12.116		4-7669865	CLIP	12.118
	4-588546	SCREW.	12.118		4-7669866	CLIP	12.118
9.	9788944-45	MLDG. PKG., W/Opng. - Top	12.116	22.	7649794-95	MOLDING, B/Wind. - Side	11.208
	14-588546	SCREW	12.118		6-7693140	CLIP	11.209
10.	9788946-47	MLDG. PKG., W/Opng. - Rear.	12.116		4-7660796	SPACER	11.209
	4-588546	SCREW.	12.118	23.	7684030-31	MOLDING, B/Wind. - Lower	11.208
11.	2-4229893	MLDG. PKG., Qtr. Panel	12.116		8-7693140	CLIP	11.209
	2-9777703	CLIP PKG.	12.118		2-7660796	SPACER.	11.209

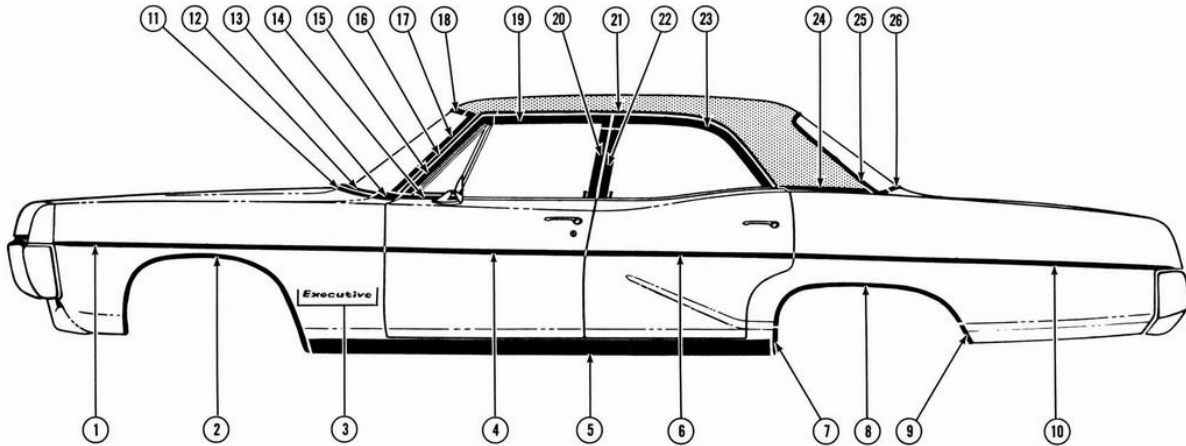

1967 EXECUTIVE 4-DOOR SEDAN—5669 (W/2-TONE PAINT)

Key Qty.	Part No.	Name	Group No.	Key Qty.	Part No.	Name	Group No.
1.	2-9788948	MLDG. PKG., Frt. Fender	8.147	13.	9788959-60	MLDG. PKG., Fender - Rear	8.147
	2-9777709	CLIP PKG.	8.148		2-9777676	SPACER	8.147
2.	9788940-41	MLDG. PKG., W/Opening	8.147		4-9420621	NUT	8.148
	12-588546	SCREW	8.148	14.	7653457-58	MOLDING, At Vent.	10.707
3.	2-9787761	LETTER "E" (Cap)	8.147	15.	4482778-79	SCALP, Frt. Door - Front	10.707
	2-9787764	LETTER "X"	8.147	16.	7685044-45	SCALP, Pillar Drip	12.075
	4-9787765	LETTER "E" (Small)	8.147	17.	7684971-72	MOLDING, W/S - Side	10.093
	2-9787766	LETTER "C"	8.147		8-7693140	CLIP	10.096
	2-9787767	LETTER "U"	8.147		6-4531604	SPACER	10.096
	2-9787768	LETTER "T"	8.147	18.	4467600	MOLDING, W/S - Upper	10.093
	2-9787769	LETTER "I"	8.147		7-7693140	CLIP	10.096
	2-9787770	LETTER "V"	8.147		7-4531604	SPACER.	10.096
	18-9419751	NUT.	8.148	19.	7629776-77	SCALP, Frt. Door - Upper	10.707
4.	4229516-17	MLDG. PKG., Frt. Door	12.112	20.	4482060-61	SCALP, Frt. Door - Rear	10.707
	2-9777682	CLIP PKG.	12.118	21.	7648328-29	SCALP, Roof Drip	12.075
5.	9789537-38	MLDG. PKG., Rocker	8.304	22.	7646876-77	SCALP, Rr. Door - Front	10.772
	2-9777708	CLIP PKG.	8.309	23.	7646845-46	SCALP, Rr. Door - Upper	10.772
6.	4229514-15	MLDG. PKG., Rr. Door	12.114	24.	7653296-97	MOLDING, Belt.	12.116
	2-9777682	CLIP PKG.	12.118		6-7587044	CLIP	12.118
7.	9788930-31	MLDG. PKG., W/Opng. - Frt.	12.116		2-7669865	CLIP	12.118
	4-588546	SCREW.	12.118	25.	7648027-28	MLDG., B/Wind. - Upr. & Side	11.208
8.	9788944-45	MLDG. PKG., W/Opng. - Top	12.116		14-7693140	CLIP.	11.209
	14-588546	SCREW	12.118		7-7660796	SPACER	11.209
9.	9788946-47	MLDG. PKG., W/Opng. - Rear.	12.116	26.	7646796-97	MOLDING, B/Wind. - Lower	11.208
	4-588546	SCREW	12.118		8-7613140	CLIP	11.209
10.	2-4229893	MLDG. PKG., Qtr. Panel	12.116		3-7660796	SPACER.	11.209
	2-9777703	CLIP PKG.	12.118				
11.	9787059	MOLDING, Hood	8.054				
12.	7657434	MOLDING, W/S - Lower	10.093				
	8-#8-18 x 3/8"	SCREW	N.S.				

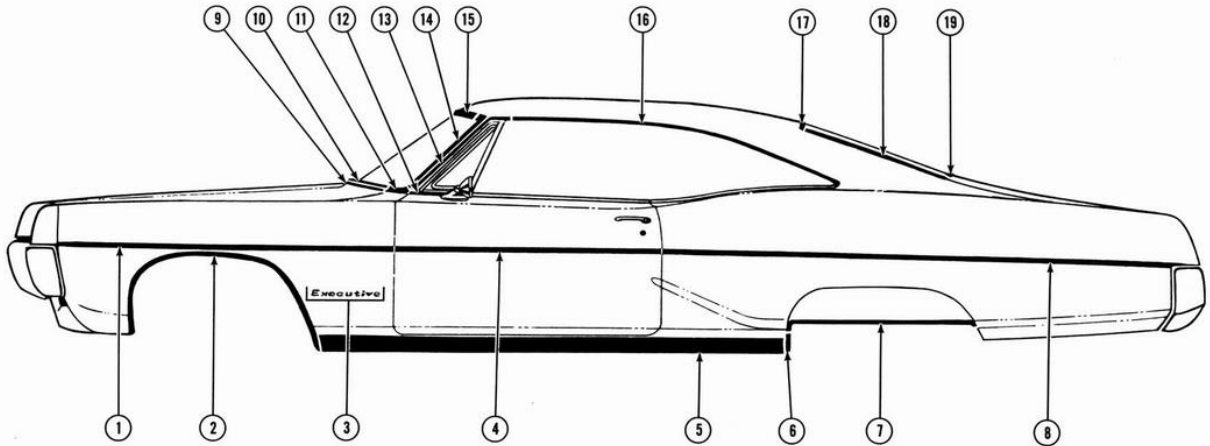

1967 EXECUTIVE 2-DOOR SPORT COUPE—5687 (W/SKIRTS)

Key Qty.	Part No.	Name	Group No.	Key Qty.	Part No.	Name	Group No.
1.	2-9788948	MLDG. PKG., Frt. Fender	8.147	10.	7657434	MOLDING, W/S - Lower	10.093
	2-9777709	CLIP PKG.	8.148		8-#8-18 x 3/8"	SCREW	N.S.
2.	9788940-41	MLDG. PKG., W/Opening	8.147	11.	9788959-60	MLDG. PKG., Fender - Rear	8.147
	12-588546	SCREW	8.148		2-9777676	SPACER	8.147
					4-9420621	NUT	8.148
3.	2-9787761	LETTER "E" (Cap)	8.147	12.	7653453-54	MOLDING, At Vent.	10.707
	2-9787764	LETTER "X"	8.147		4-#8-18 x 3/8"	SCREW	N.S.
	4-9787765	LETTER "E" (Small)	8.147	13.	7670128-29	SCALP, Pillar - Drip	12.075
	2-9787766	LETTER "C"	8.147		8-#8-18 x 3/8"	SCREW	N.S.
	2-9787767	LETTER "U"	8.147	14.	7684973-74	MOLDING, W/S - Side	10.093
	2-9787768	LETTER "T"	8.147		8-7693140	CLIP	10.096
	2-9787769	LETTER "I"	8.147		6-4531604	SPACER	10.096
	2-9787770	LETTER "V"	8.147	15.	4467604	MOLDING, W/S - Upper	10.093
	16-9419751	NUT	8.148		7-7693140	CLIP	10.096
					7-4531604	SPACER	10.096
4.	2-4229518	MLDG. PKG., Door	12.112	16.	7650002-03	SCALP, Roof	12.075
	2-9777682	CLIP PKG.	12.118	17.	7646717-18	MOLDING, B/Wind. - Upper	11.208
5.	9789537-38	MLDG. PKG., Rocker	8.304		10-7693140	CLIP	11.209
	9777708	CLIP PKG.	8.309		3-7660796	SPACER	11.209
6.	9788936-37	MLDG. PKG., W/Opng. - Frt.	12.116	18.	7647558-59	MOLDING, B/Wind. - Side	11.208
	4-588546	SCREW	12.118		8-7693140	CLIP	11.209
					4-7660796	SPACER	11.209
7.	9788932-33	MLDG. PKG., Skirt	8.176	19.	7660862	MOLDING, B/Wind. - Lower	11.208
	2-9789946	CLIP PKG.	8.176		8-7693140	CLIP	11.209
					8-7664118	SPACER	11.209
8.	2-4229894	MLDG. PKG., Qtr. Panel	12.116				
	2-9777704	CLIP PKG.	12.118				
9.	9787059	MOLDING, Hood	8.054				

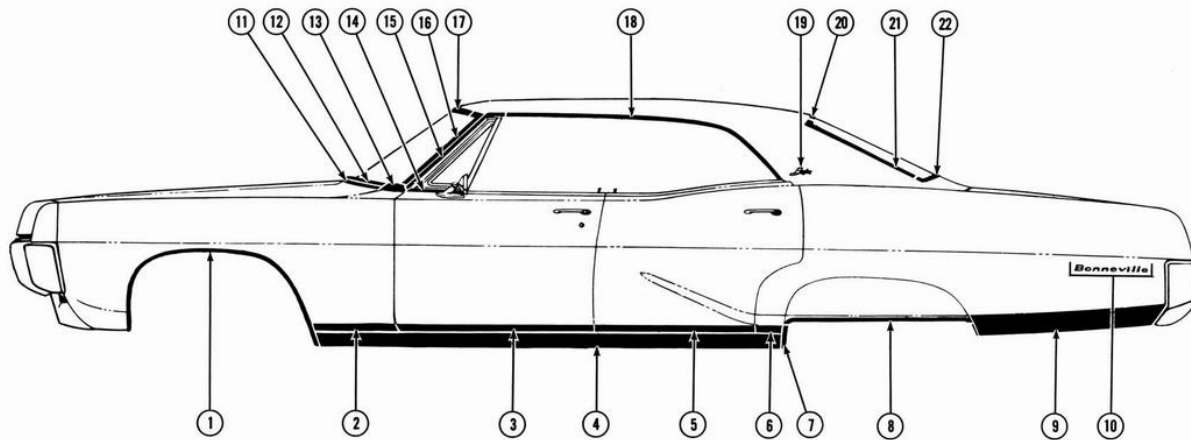

1967 BONNEVILLE 4-DOOR HARDTOP—6239 (W/BROUGHAM OPTION)

Key Qty.	Part No.	Name	Group No.	Key Qty.	Part No.	Name	Group No.
1.	9788940-41	MLDG. PKG., W/Opening . . .	8.147	11.	9787059	MOLDING, Hood	8.054
	12-588546	SCREW	8.148	12.	7657434	MOLDING, W/S - Lower	10.093
					8-#8-18 x 3/8"	SCREW	N.S.
2.	9788951-52	MLDG. PKG., Fender - Lower	8.147	13.	9788959-60	MLDG. PKG., Fender - Rear	8.147
	2-9777711	CLIP PKG.	8.148		2-9777676	SPACER	8.147
3.	4229510-11	MLDG. PKG., Frt. Door	12.112		4-9420621	NUT	8.921
	2-9777681	CLIP PKG.	12.118	14.	7653453-54	MOLDING, At Vent	10.707
4.	9788926-27	MLDG. PKG., Rocker	8.304		4-#8-18 x 3/8"	SCREW	N.S.
	2-9777708	CLIP PKG.	8.309	15.	7670128-29	SCALP, Pillar - Drip	12.075
5.	2-4229509	MLDG. PKG., Rr. Door	12.114		8-#8-18 x 3/8"	SCREW	N.S.
	2-9777681	CLIP PKG.	12.118	16.	7684973-74	MOLDING, W/S - Side	10.093
6.	2-4229899	MLDG. PKG., Frt. of W/Opng..	12.116		8-7693140	CLIP	10.096
	2-7658109	CLIP	12.118		6-4531604	SPACER	10.096
7.	9788936-37	MLDG. PKG., W/Opng. - Front	12.116	17.	4467604	MOLDING, W/S - Upper.	10.093
	4-588546	SCREW	12.118		7-7693140	CLIP	10.096
					7-4531604	SPACER.	10.096
8.	9788932-33	MLDG. PKG., Skirt	8.176	18.	7647431-32	SCALP, Roof	12.075
	2-9789946	CLIP PKG.	8.176	19.	2-7681947	PLATE, "Brougham"	12.812
9.	4229891-92	MLDG. PKG., Rr. of W/Opng..	12.116		4-7580794	NUT	12.812
	2-9777702	CLIP PKG.	12.118	20.	7648206	MOLDING, B/Wind. - Upper	11.208
10.	2-7681451	LETTER "B"	12.116		6-7693140	CLIP	11.209
	2-7681452	LETTER "O"	12.116		3-7660796	SPACER.	11.209
	4-7681453	LETTER "N"	12.116	21.	7649794-95	MOLDING, B/Wind. - Side	11.208
	4-7681454	LETTER "E"	12.116		6-7693140	CLIP	11.209
	2-7681455	LETTER "V"	12.116		4-7660796	SPACER.	11.209
	2-7681456	LETTER "I"	12.116	22.	7684030-31	MOLDING, B/Wind. - Lower.	11.208
	4-7681457	LETTER "L"	12.116		8-7693140	CLIP	11.209
	20-3/32" I.D. x 13/64" O.D. x 1/6"	WASHER	N.S.		2-7660796	SPACER	11.209
	20-9419763	NUT.	12.118				

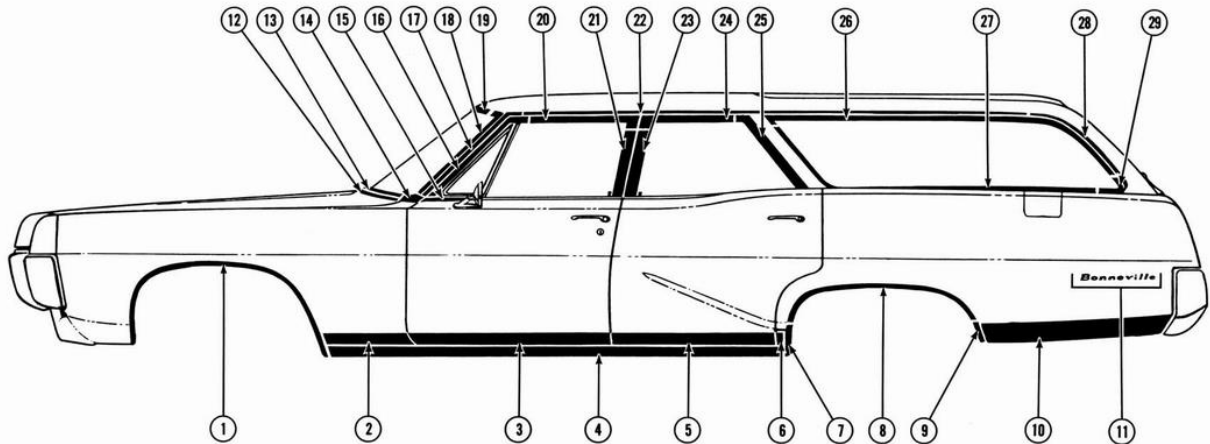

1967 BONNEVILLE STATION WAGON—6245

Key Qty.	Part No.	Name	Group No.	Key Qty.	Part No.	Name	Group No.
1.	9788940-41	MLDG. PKG., W/Opening . . .	8.147	13.	7657434	MOLDING, W/S - Lower	10.093
	12-588546	SCREW	8.148		8-#8-18	x 3/8" SCREW	N.S.
2.	9788951-52	MLDG. PKG., Fender - Lower	8.147	14.	9788959-60	MLDG. PKG., Fender - Rear	8.147
	2-9777711	CLIP PKG.	8.148		2-9777676	SPACER	8.147
3.	4229510-11	MLDG. PKG., Frt. Door	12.112		4-9420621	NUT	8.148
	2-9777681	CLIP PKG.	12.118	15.	7653457-58	MOLDING, At Vent	10.707
4.	9788928-29	MLDG. PKG., Rocker	8.304	16.	4482778-79	SCALP, Frt. Door - Front	10.707
	2-9777708	CLIP PKG.	8.309	17.	7585044-45	SCALP, Pillar - Drip	12.075
5.	2-4229509	MLDG. PKG., Rr. Door	12.114		8-#8-18	x 3/8" SCREW	N.S.
	2-9777681	CLIP PKG.	12.118	18.	7684971-72	MOLDING, W/S - Side	10.093
6.	2-4229898	MLDG. PKG., Frt. of W/Opng..	12.116		8-7693140	CLIP	10.096
	2-7658109	CLIP	12.118		6-4531604	SPACER	10.096
7.	9788930-31	MLDG. PKG., W/Opng. - Frt.	12.116	19.	4467600	MOLDING, W/S - Upper	10.093
	4-588546	SCREW	12.118		7-7693140	CLIP	10.096
8.	9788944-45	MLDG. PKG., W/Opng. - Top	12.116		7-4531604	SPACER	10.096
	14-588546	SCREW	12.118	20.	7629776-77	SCALP, Frt. Door - Upper	10.707
9.	9788942-43	MLDG. PKG., W/Opng. - Rear.	12.116	21.	4482060-61	SCALP, Frt. Door - Rear.	10.707
	4-588546	SCREW	12.118	22.	4468346-47	SCALP, Roof - Front	12.075
10.	4229904-05	MLDG. PKG., Rr. of W/Opng.	12.116	23.	7646876-77	SCALP, Rr. Door - Front	10.772
	2-9777702	CLIP PKG.	12.118	24.	7663380-81	SCALP, Rr. Door - Upper	10.772
11.	1-7681451	LETTER "B", R.H.	12.116	25.	7648198-99	SCALP, Rr. Door - Rear.	10.772
	1-7681452	LETTER "O", R.H.	12.116	26.	7639450-51	MOLDING, Qtr. Wind. - Upr.	11.031
	2-7681453	LETTER "N", R.H.	12.116		14-7693140	CLIP.	11.032
	2-7681454	LETTER "E", R.H.	12.116		2-4501000	CLIP.	11.032
	1-7681455	LETTER "V", R.H.	12.116		2-#8-18	x 3/8" SCREW	N.S.
	1-7681456	LETTER "I", R.H.	12.116		10-4531604	SPACER	11.032
	2-7681457	LETTER "L", R.H.	12.116	27.	7639392-93	MOLDING, Qtr. Wind. - Lwr.	11.031
	10-3/32" I.D. x 13/64" O.D. x 1/16"	WASHER	N.S.		12-7693140	CLIP.	11.032
	10-9419763	NUT.	12.118		6-4501000	CLIP.	11.032
	1-7681744	LETTER "B", L.H.	12.116		6-#8-18	x 3/8" SCREW	N.S.
	1-7681745	LETTER "O", L.H.	12.116		10-4531604	SPACER	11.032
	2-7681746	LETTER "N", L.H.	12.116	28.	7646851-52	SCALP, Roof - Rear	12.075
	2-7681747	LETTER "E", L.H.	12.116	29.	2-7647286	ESCUTCHEON, Qtr. Window	11.031
	1-7681748	LETTER "V", L.H.	12.116				
	1-7681749	LETTER "I", L.H.	12.116				
	2-7681750	LETTER "L", L.H.	12.116				
	20-7600028	CLIP.	12.118				
12.	9787059	MOLDING, Hood	8.054				

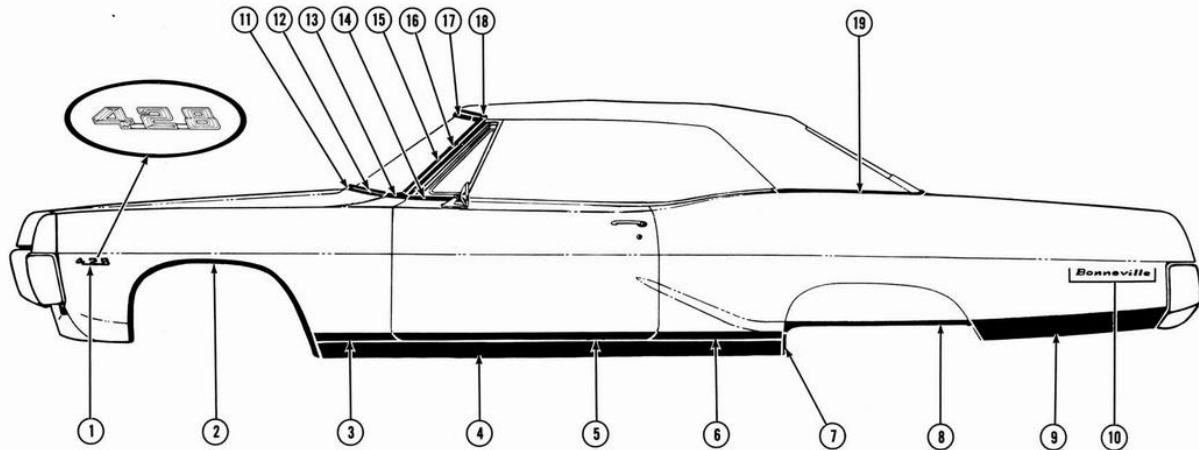

1967 BONNEVILLE CONVERTIBLE COUPE—6267 (428 ENGINE)

Key Qty.	Part No.	Name	Group No.	Key Qty.	Part No.	Name	Group No.
1.	9787948-49	EMBLEM, "428"	8.147	11.	9787059	MOLDING, Hood	8.054
	6-9420621	NUT	8.148				
2.	9788940-41	MLDG. PKG., W/Opening	8.147	12.	7657434	MOLDING, W/S - Lower.	10.093
	12-588546	SCREW	8.148		8-#8-18 x 3/8"	SCREW	N.S.
3.	9788951-52	MLDG. PKG., Fender - Lower	8.147	13.	9788969-70	MLDG. PKG., Fender - Rear	8.147
	2-9777711	CLIP PKG.	8.148		2-9777676	SPACER	8.147
					4-9420621	NUT	8.148
4.	9788926-27	MLDG. PKG., Rocker	8.304	14.	7653453-54	MOLDING, At Vent.	10.707
	2-9777708	CLIP PKG.	8.309		4-#8-18 x 3/8"	SCREW	N.S.
5.	4229512-13	MLDG. PKG., Door	12.112	15.	7600994-95	MOLDING, Pillar - Finish	10.093
	2-9777681	CLIP PKG.	12.118		10-#8-18 x 3/8"	SCREW	N.S.
					2-#8-18 x 3/8"	HEX SCREW	N.S.
6.	4229900-01	MLDG. PKG., Frt. of W/Opng.	12.116		2-4409925	SCREW	10.096
	6-7658109	CLIP	12.118	16.	7684973-74	MOLDING, W/S - Side	10.093
					8-7693140	CLIP	10.096
7.	9788936-37	MLDG. PKG., W/Opng. - Frt.	12.116		6-4531604	SPACER.	10.096
	4-588546	SCREW.	12.118	17.	4467604	MOLDING, W/S - Upper	10.093
					7-7693140	CLIP	10.096
					7-4531604	SPACER	10.096
8.	9788932-33	MLDG. PKG., Skirt	8.176	18.	7584209	HEADER	10.093
	2-9789946	CLIP PKG.	8.176		4-#8-18 x 1/2"	SCREW	N.S.
					4-#8-18 x 3/8"	SCREW	N.S.
9.	4229891-92	MLDG. PKG., Rr. of W/Opng.	12.116	19.	3917770-69	MLDG. PKG., Finish	12.116
	2-9777702	CLIP PKG.	12.118		12-7672609	CLIP.	12.118
10.	2-7681451	LETTER "B"	12.116		5-#8-18 x 1/4"	SCREW	N.S.
	2-7681452	LETTER "O"	12.116				
	4-7681453	LETTER "N"	12.116				
	4-7681454	LETTER "E"	12.116				
	2-7681455	LETTER "V"	12.116				
	2-7681456	LETTER "I"	12.116				
	4-7681457	LETTER "L"	12.116				
	20-3/32" I.D. x 13/64" O.D. x 1/16"	WASHER	N.S.				
	20-9419763	NUT.	12.118				

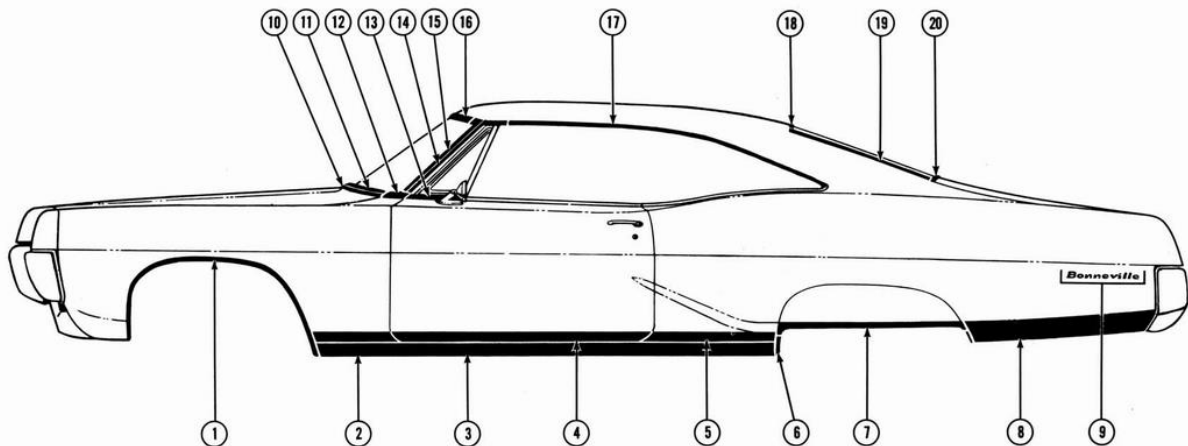

1967 BONNEVILLE 2-DOOR SPORT COUPE-6287

Key	Qty.	Part No.	Name	Group No.	Key	Qty.	Part No.	Name	Group No.
1.		9788940-41	MLDG. PKG., W/Opening . . .	8.147	11.		7657434	MOLDING, W/S - Lower	10.093
		12-588546	SCREW	8.148			8-#8-18	x 3/8" SCREW	N.S.
2.		9788951-52	MLDG. PKG., Fender	8.147	12.		9788959-60	MLDG. PKG., Fender - Rear . .	8.147
		2-9777711	CLIP PKG.	8.148			2-9777676	SPACER	8.147
3.		9788926-27	MLDG. PKG., Rocker	8.304			4-9420621	NUT	8.148
		2-9777708	CLIP PKG.	8.309	13.		7653453-54	MOLDING, At Vent	10.707
							4-#8-18	x 3/8" SCREW	N.S.
4.		4229512-13	MLDG. PKG., Door	12.112	14.		7670128-29	SCALP, Pillar - Drip	12.075
		2-9777681	CLIP PKG.	12.118			8-#8-18	x 3/8" SCREW	N.S.
5.		4229900-01	MLDG. PKG., Frt. of W/Opng..	12.116	15.		7684973-74	MOLDING, W/S - Side.	10.093
		6-7658109	CLIP	12.118			8-7693140	CLIP	10.096
6.		9788936-37	MLDG. PKG., W/Opng. - Front	12.116			6-4531604	SPACER.	10.096
		4-588546	SCREW	12.118	16.		4467604	MOLDING, W/S - Upper.	10.093
7.		9788932-33	MLDG. PKG., Skirt	8.176			7-7693140	CLIP	10.096
		2-9789946	CLIP PKG.	8.176			7-4531604	SPACER	10.096
8.		4229891-92	MLDG. PKG., Rr. of W/Opng..	12.116	17.		7650002-03	SCALP, Roof	12.075
		2-9777702	CLIP PKG.	12.118	18.		7646717-18	MOLDING, B/Wind. - Upper .	11.208
9.		2-7681451	LETTER "B"	12.116			10-7693140	CLIP.	11.209
		2-7681452	LETTER "O"	12.116			3-7660796	SPACER	11.209
		4-7681453	LETTER "N"	12.116	19.		7647558-59	MOLDING, B/Wind. - Side. . .	11.208
		4-7681454	LETTER "E"	12.116			8-7693140	CLIP	11.209
		2-7681455	LETTER "V"	12.116			4-7660796	SPACER.	11.209
		2-7681456	LETTER "I"	12.116	20.		7660862	MOLDING, B/Wind. - Lower . . .	11.208
		4-7681457	LETTER "L"	12.116			8-7693140	CLIP	11.209
		20-3/32" I.D. x 13/64" O.D. x 1/16"	WASHER	N.S.			8-7660796	SPACER.	11.209
		20-9419763	NUT.	12.118					
10.		9787059	MOLDING, Hood	8.054					

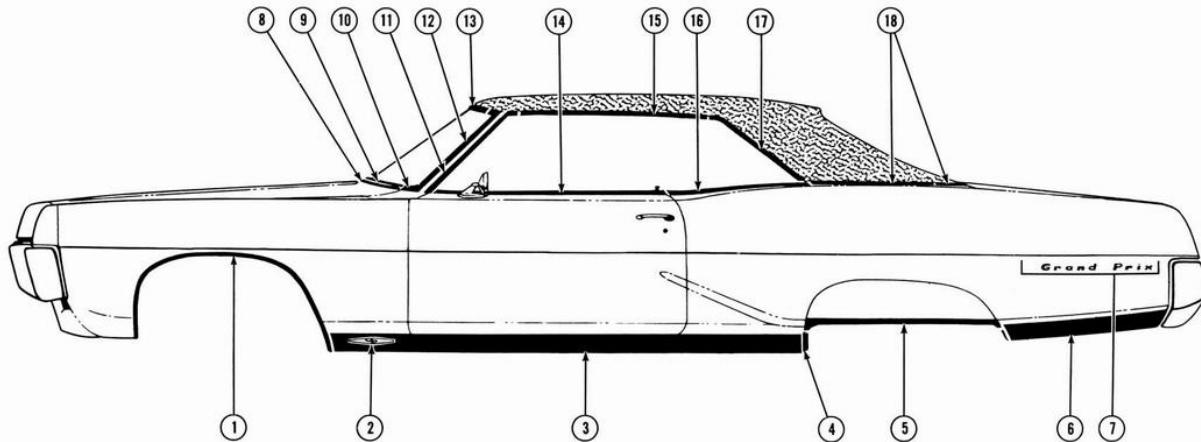

1967 GRAND PRIX 2-DOOR SPORT COUPE—6657 (W/CORDOVA TOP & SKIRTS)

Key Qty.	Part No.	Name	Group No.	Key Qty.	Part No.	Name	Group No.
1.	9788940-41	MLDG. PKG., W/Opening . . .	8.147	8.	9787059	MOLDING, Hood	8.054
	12-588546	SCREW	8.148				
2.	2-9788169	EMBLEM, "GP"	8.304	9.	7657434	MOLDING, W/S - Lower	10.093
	4-176464	SCREW	8.309		8-#8-18 x 3/8"	SCREW	N.S.
	4-#10	WASHER.	N.S.	10.	9788959-60	MLDG. PKG., Fender - Rear . .	8.147
3.*	9788934-35	MLDG. PKG., Rocker	8.304		2-9777676	SPACER	8.147
	2-9777708	CLIP PKG.	8.309		4-9420621	NUT	8.148
3**	9789890-91	MLDG. PKG., Rocker	8.304	11.	7670128-29	SCALP, Pillar - Drip	12.075
	2-9777708	CLIP PKG.	8.309		8-#8-18 x 3/8"	SCREW	N.S.
4.*	9788936-37	MLDG. PKG., W/Opng. - Frt. .	12.116	12.	7684973-74	MOLDING, W/S - Side	10.093
	4-588546	SCREW.	12.118		8-7693140	CLIP	10.096
5.	9788932-33	MLDG. PKG., Skirt	8.176		6-4531604	SPACER	10.096
	2-9789946	CLIP PKG.	8.176	13.	4467604	MOLDING, W/S - Upper	10.093
6.	4229902-03	MLDG. PKG., Rr. of W/Opng. .	12.116		7-7693140	CLIP	10.096
	2-9777702	CLIP PKG.	12.118		7-4531604	SPACER.	10.096
7.	2-7664337	LETTER "G"	12.116	14.	7656016-17	MOLDING, Door - Window. . .	10.707
	4-7664338	LETTER "R"	12.116		8-#8-18 x 1/2"	SCREW	N.S.
	2-7664339	LETTER "A"	12.116	15.	4481726-27	SCALP, Roof	12.075
	2-7664340	LETTER "N"	12.116	16.	7648130-31	MOLDING, Qtr. Window	11.031
	2-7664341	LETTER "D"	12.116		6-#8-18 x 1/2"	SCREW	N.S.
	2-7664342	LETTER "P"	12.116	17.	7646665-66	SCALP, Roof - Rear	12.075
	2-7664343	LETTER "I"	12.116	18.	7648714-15	MOLDING, Belt.	12.116
	2-7664344	LETTER "X"	12.116		8-7731589	CLIP	12.118
	16-3/32" I.D. x 13/64" O.D. x 1/16"	WASHER	N.S.		2-7669079	CLIP	12.118
	16-9419763	NUT.	12.118		2-9419764	NUT	12.118

***FIRST TYPE—USE THESE PKGS. WITH REAR WHEEL OPENING FRONT CAP & REAR WHEEL OPENING COVER MOLDING.**

****SECOND TYPE—USE THIS ROCKER MOLDING FOR THOSE MODELS NOT HAVING REAR WHEEL OPENING FRONT CAP & NO REAR WHEEL OPENING COVER MOLDING.**

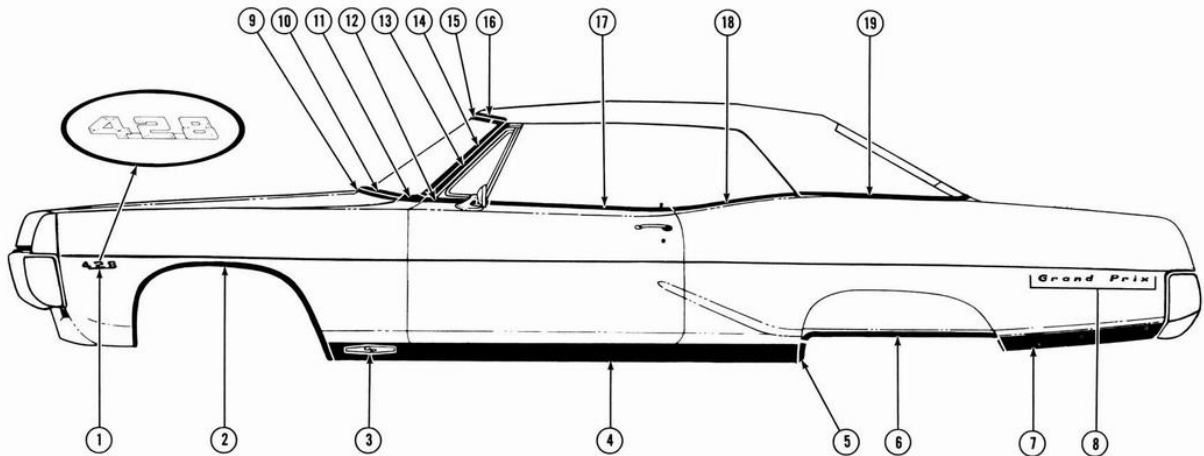

1967 GRAND PRIX CONVERTIBLE COUPE—6667 (428 ENGINE & SKIRTS)

Key Qty.	Part No.	Name	Group No.	Key Qty.	Part No.	Name	Group No.
1.	9787948-49	EMBLEM, "428"	8.147	10.	7657434	MOLDING, W/S - Lower	10.093
	6-9420621	NUT	8.148		8-#8-18 x 3/8"	SCREW	N.S.
2.	9788940-41	MLDG. PKG., W/Opening	8.147	11.	9788969-70	MLDG. PKG., Fender - Rear	8.147
	12-588546	SCREW	8.148		2-9777676	SPACER	8.147
					4-9420621	NUT	8.148
3.	2-9788169	EMBLEM, "GP"	8.304	12.	7653451-52	MOLDING, At Vent.	10.707
	4-176464	SCREW	8.309		4-#8-18 x 3/8"	SCREW	N.S.
	4-#10	WASHER	N.S.				
4.*	9788934-35	MLDG. PKG., Rocker	8.304	13.	7600994-95	MOLDING, Pillar - Finish	10.093
	2-9777708	CLIP PKG.	8.309		10-#8-18 x 3/8"	SCREW	N.S.
4**	9789890-91	MLDG. PKG., Rocker	8.304		2-#8-18 x 3/8"	HEX. SCREW	N.S.
	2-9777708	CLIP PKG.	8.309		2-4409925	SCREW	10.096
5.*	9788936-37	MLDG. PKG., W/Opng. - Frt.	12.116	14.	7684973-74	MOLDING, W/S - Side	10.093
	4-588546	SCREW	12.118		8-7693140	CLIP	10.096
					6-4531604	SPACER	10.096
6.	9788932-33	MLDG. PKG., Skirt	8.176	15.	4467604	MOLDING, W/S - Upper	10.093
	2-9789946	CLIP PKG.	8.176		7-7693140	CLIP	10.096
					7-4531604	SPACER	10.096
7.	4229902-03	MLDG. PKG., Rr. of W/Opng.	12.116	16.	7584209	HEADER	10.093
	2-9777702	CLIP PKG.	12.118		4-#8-18 x 1/2"	SCREW	N.S.
					4-#8-18 x 3/8"	SCREW	N.S.
8.	2-7664337	LETTER "G"	12.116	17.	7646822-23	MOLDING, Door - Window	10.707
	4-7664338	LETTER "R"	12.116		4-#8-18 x 1/2"	SCREW	N.S.
	2-7664339	LETTER "A"	12.116		2-#8-18 x 1/4"	SCREW	N.S.
	2-7664340	LETTER "N"	12.116	18.	7645838-39	MOLDING, Qtr. Window	11.031
	2-7664341	LETTER "D"	12.116		8-#8-18 x 3/8"	SCREW	N.S.
	2-7664342	LETTER "P"	12.116	19.	7698286-87	MOLDING, Finish	12.116
	2-7664343	LETTER "I"	12.116		13-7672609	CLIP	12.118
	2-7664344	LETTER "X"	12.116		5-#8-18 x 3/8"	SCREW	N.S.
	16-3/32" I.D. x 3/64" O.D. x 1/16"	WASHER	N.S.				
	16-9419763	NUT	12.118				
9.	9787059	MOLDING, Hood	8.054				

***FIRST TYPE—USE THESE PKGS. WITH REAR WHEEL OPENING FRONT CAP & REAR WHEEL OPENING COVER MOLDING.**
****SECOND TYPE—USE THIS ROCKER MOLDING FOR THOSE MODELS NOT HAVING REAR WHEEL OPENING FRONT CAP & NO REAR WHEEL OPENING COVER MOLDING.**

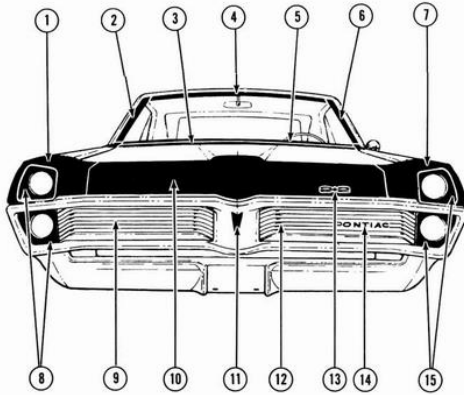

**1967 CATALINA-EXECUTIVE-2 + 2
FRONT END VIEW
TYPICAL OF 11-35-45-69 STYLES**

Key	Qty.	Part No.	Name	Group No.
1.		9787016 EXT., Fender		8.131
		2-9419402 SCREW		8.977
		2-11/32" I.D. x 7/8" O.D. WASHER		N.S.
		3-9419844 NUT		8.921
		2-120375 NUT		8.915
2.		7684971 MLDG., W/S - Side		10.093
		4-7693140 CLIP		10.096
		3-4531604 SPACER		10.096
3.		9787059 MOLDING, Hood		8.054
4.		4467600 MOLDING, W/S - Upper		10.093
		7-7693140 CLIP		10.096
		7-4531604 SPACER		10.096
5.		7657434 MLDG., W/S - Lower		10.093
		8-#8-18 x 3/8" SCREW		N.S.
6.		7684972 MLDG., W/S - Side		10.093
		4-7693140 CLIP		10.096
		3-4531604 SPACER		10.096
7.		9787017 EXT., Fender		8.131
		2-9419402 SCREW		8.977
		2-11/32" I.D. x 7/8" O.D. WASHER		N.S.
		3-9419844 NUT		8.921
		2-120375 NUT		8.915
8.		9787078 BEZEL, Upper - R.H.		2.728
		9787080 BEZEL, Lower - R.H.		2.728
		6-380382 NUT		2.729
		6-9414754 SCREW		8.977
9.		9786707 GRILLE, R.H.		1.266
10.		9786234 PANEL, Center		1.266
		1-9419844 NUT		8.921
		6-9/32" I.D. x 1" O.D. WASHER		N.S.
		6-1/4"-20 x 5/8" SCREW		N.S.
11.		9788410 EMBLEM		7.831
		1-9786887 PAD		7.831
		2-120375 NUT		8.915
12.		9786708 GRILLE, L.H.		1.266
13.		4519024 PLATE, "2+2"		1.303
		2-9420621 NUT		1.303
14.		9788403 PLATE, "Pontiac"		1.303
		2-9420224 NUT		1.303
15.		9787079 BEZEL, Upper - L.H.		2.728
		9787081 BEZEL, Lower - L.H.		2.728
		6-380382 NUT		2.729
		6-9414754 SCREW		8.977

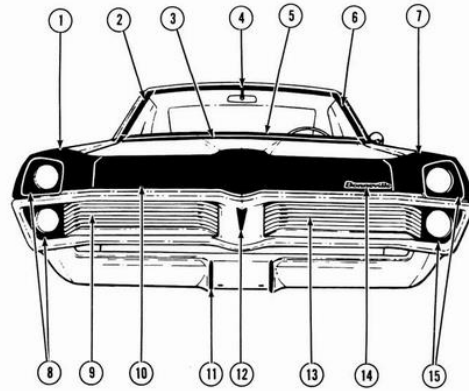

**1967 BONNEVILLE FRONT END VIEW
TYPICAL OF 39 & 87 STYLES**

Key	Qty.	Part No.	Name	Group No.
1.		9787016 EXT., Fender		8.131
		2-9419402 SCREW		8.977
		2-11/32" I.D. x 7/8" O.D. WASHER		N.S.
		3-9419844 NUT		8.921
		2-120375 NUT		8.915
2.		7684973 MLDG., W/S - Side		10.093
		4-7693140 CLIP		10.096
		3-4531604 SPACER		10.096
3.		9787059 MOLDING, Hood		8.054
4.		4467604 MOLDING, W/S - Upper		10.093
		7-7693140 CLIP		10.096
		7-4531604 SPACER		10.096
5.		7657434 MOLDING, W/S - Lower		10.093
		8-#8-18 x 3/8" SCREW		N.S.
6.		7684974 MOLDING, W/S - Side		10.093
		4-7693140 CLIP		10.096
		3-4531604 SPACER		10.096
7.		9787017 EXT., Fender		8.131
		2-9419402 SCREW		8.977
		2-11/32" I.D. x 7/8" O.D. WASHER		N.S.
		3-9419844 NUT		8.921
		2-120375 NUT		8.915
8.		9787078 BEZEL, Upper - R.H.		2.728
		9787080 BEZEL, Lower - R.H.		2.728
		6-380382 NUT		2.729
		6-9414754 SCREW		8.977
9.		9786707 GRILLE, R.H.		1.266
10.		9786234 PANEL, Center		1.266
		1-9419844 NUT		8.921
		6-9/32" I.D. x 1" O.D. WASHER		N.S.
		6-1/4"-20 x 5/8" SCREW		N.S.
11.		2-9786750 GUARD		7.800
		4-9420621 NUT		8.921
12.		9788410 EMBLEM		7.831
		1-9786887 PAD		7.831
		2-120375 NUT		8.915
13.		9786708 GRILLE, L.H.		1.266
14.		7666750 PLATE, "Bonneville"		1.303
		3-9420621 NUT		1.303
15.		9787079 BEZEL, Upper - L.H.		2.728
		9787081 BEZEL, Lower - L.H.		2.728
		6-380382 NUT		2.729
		6-9414754 SCREW		8.977

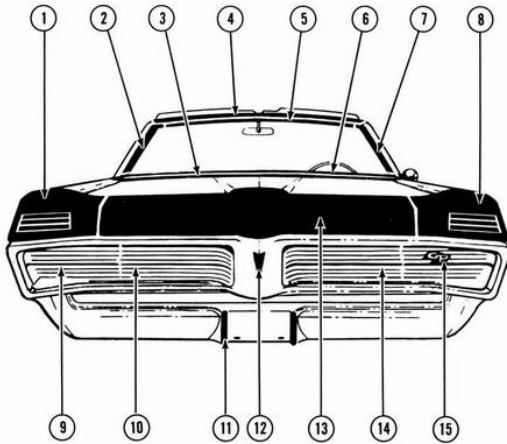

**1967 GRAND PRIX FRONT END VIEW
6667 (TYPICAL OF 67 STYLES)**

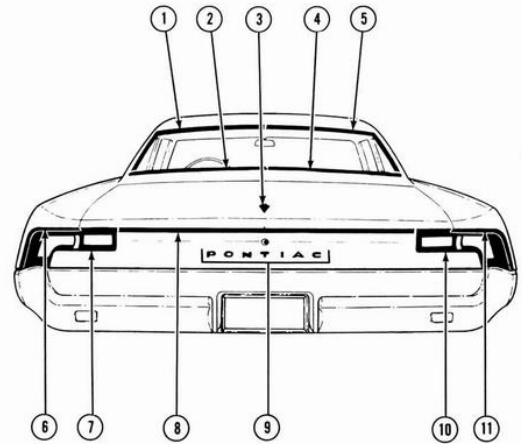

**1967 CATALINA REAR END VIEW
TYPICAL OF 11 & 69 STYLES**

Key	Qty.	Part No.	Name	Group No.
1.		9786992	EXT., Fender	8.131
	2-	9419402	SCREW	8.977
	3-	120375	NUT	8.915
	3-	17/64"	I.D. x 1/2" O.D. WASHER.	N.S.
	2-	11/32"	I.D. x 7/8" O.D. WASHER.	N.S.
2.		7684973	MOLDING, W/S - Side	10.093
	4-	7693140	CLIP	10.096
	3-	4531604	SPACER	10.096
3.		9787059	MOLDING, Hood	8.054
4.		7584209	MOLDING, Header	10.093
	4-	#8-18 x 1/2"	SCREW	N.S.
	4-	#8-18 x 3/8"	SCREW	N.S.
5.		4467604	MOLDING, W/S - Upper.	10.093
	7-	7693140	CLIP	10.096
	7-	4531604	SPACER	10.096
6.		7657434	MOLDING, W/S - Lower.	10.093
	8-	#8-18 x 3/8"	SCREW	N.S.
7.		7684974	MOLDING, W/S - Side	10.093
	4-	7693140	CLIP	10.096
	3-	4531604	SPACER	10.096
8.		9786993	EXT., Fender	8.131
	2-	9419402	SCREW	8.977
	3-	120375	NUT	8.915
	3-	17/64"	I.D. x 1/2" O.D. WASHER.	N.S.
	2-	11/32"	I.D. x 7/8" O.D. WASHER.	N.S.
9.	2-	9786748	DOOR, H/Lamp	2.728
10.		9786752	GRILLE, R.H.	1.266
11.	2-	9786750	GUARD	7.800
	4-	9420621	NUT	8.921
12.		9788410	EMBLEM	7.831
	1-	9786887	PAD	7.831
	2-	120375	NUT	8.915
13.		9786259	PANEL, Center	1.266
	1-	9419844	NUT	8.921
	6-	9/32"	I.D. x 1" O.D. WASHER	N.S.
	6-	1/4"-20 x 5/8"	SCREW	N.S.
14.		9786753	GRILLE, L.H.	1.266
15.		9787570	EMBLEM, "GP".	1.303
	2-	9420224	NUT	8.921

Key	Qty.	Part No.	Name	Group No.
1.		7648028	MOLDING, B/Wind. - Upper	11.208
	7-	7693140	CLIP	11.209
	4-	7660796	SPACER	11.209
2.		7646797	MOLDING, B/Wind. - Lower	11.208
	4-	7693140	CLIP	11.209
	2-	7660796	SPACER	11.209
3.		7663791	EMBLEM, Lid	12.182
	2-	5/32"	I.D. x 1/2" O.D. x 3/16"	
			WASHER	N.S.
	2-	7616775	NUT	12.183
4.		7646796	MOLDING, B/Wind. - Lower.	11.208
	4-	7693140	CLIP	11.209
	2-	7660796	SPACER	11.209
5.		7648027	MOLDING, B/Wind. - Upper	11.208
	7-	7693140	CLIP	11.209
	4-	7660796	SPACER	11.209
6.		4229623	MLDG. PKG., Paint	12.116
	1-	9777683	CLIP PKG.	12.118
7.		5958781	BEZEL, T/Lamp	2.681
8.		4229628	MLDG. PKG., Rear End	12.182
	1-	9777685	CLIP PKG.	12.183
9.	1-	7663126	LETTER "P"	12.182
	1-	7663127	LETTER "O"	12.182
	1-	7663128	LETTER "N"	12.182
	1-	7663129	LETTER "T"	12.182
	1-	7663130	LETTER "I"	12.182
	1-	7663131	LETTER "A"	12.182
	1-	7663132	LETTER "C"	12.182
	14-	3/32"	I.D. x 13/64" O.D. x 1/16"	
			WASHER	N.S.
	14-	9419763	NUT	12.183
10.		5958782	BEZEL, T/Lamp	2.681
11.		4229624	MLDG. PKG., Paint	12.116
	1-	9777683	CLIP PKG.	12.118

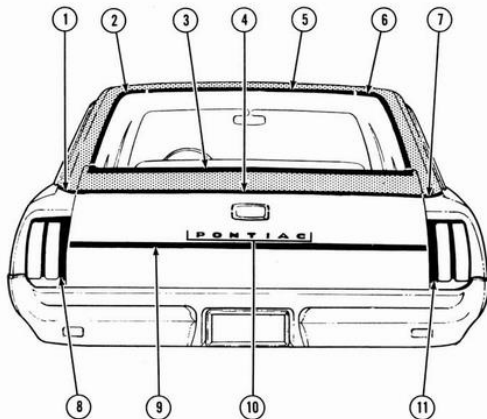

**1967 CATALINA STATION WAGON
REAR END VIEW
5235-45**

Key	Qty.	Part No.	Name	Group No.
1.		3914081	MLDG. PKG., Belt	12.180
		2-7656440	CLIP	12.180
		1-#8-18 x 3/8"	SCREW	N.S.
2.		4468439	MOLDING, Side	12.180
		3-#8-18 x 1/4"	SCREW	N.S.
3.		4470736	MOLDING, Lower.	12.180
		6-4491306	CLIP	12.180
4.		4229554	MLDG. PKG., Belt	12.180
		6-7657696	CLIP	12.180
		2-7657426	CLIP	12.180
		2-#8-32 x 7/32"	SCREW	N.S.
5.		4468416	MOLDING, Upper	12.180
		4-#8-18 x 1/4"	SCREW	N.S.
6.		4468438	MOLDING, Side	12.180
		3-#8-18 x 1/4"	SCREW	N.S.
7.		3914082	MLDG. PKG., Belt	12.180
		2-7656440	CLIP	12.180
		1-#8-18 x 3/8"	SCREW	N.S.
8.		7648446	EXT., At Lamp.	12.940
		4-1/4"-20 x 1-3/16"	SCREW	N.S.
9.		4229647	MLDG. PKG., Lower	12.180
		1-9777691	CLIP PKG.	12.180
10.		1-7663094	LETTER "P"	12.180
		1-7663095	LETTER "O"	12.180
		1-7663096	LETTER "N"	12.180
		1-7663097	LETTER "T"	12.180
		1-7663098	LETTER "I"	12.180
		1-7663099	LETTER "A"	12.180
		1-7663100	LETTER "C"	12.180
		9-9419764	NUT	12.180
11.		7648445	EXT., At Lamp	12.940
		4-1/4"-20 x 1-3/16"	SCREW	N.S.

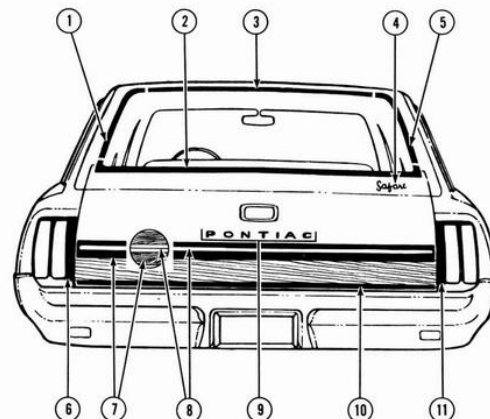

**1967 EXECUTIVE SAFARI STATION WAGON
REAR END VIEW
5635-45**

Key	Qty.	Part No.	Name	Group No.
1.		4468439	MOLDING, Side	12.180
		3-#8-18 x 1/4"	SCREW	N.S.
2.		4470736	MOLDING, Lower	12.180
		6-4491306	CLIP	12.180
3.		4468416	MOLDING, Upper	12.180
		4-#8-18 x 1/4"	SCREW	N.S.
4.		7694487	PLATE, "Safari".	12.180
		2-9419764	NUT	12.180
5.		4468438	MOLDING, Side	12.180
		3-#8-18 x 1/4"	SCREW	N.S.
6.		7648446	EXT., At Lamp	12.940
		4-1/4"-20 x 1-3/16"	SCREW	N.S.
7.		4229660	MLDG. PKG., (Sim. Wood).	12.180
		7-#8-18 x 3/8"	SCREW	N.S.
8.		4229659	MLDG. PKG., (Chrome)...	12.180
		9-#8-18 x 3/8"	SCREW	N.S.
9.		1-7663094	LETTER "P"	12.180
		1-7663095	LETTER "O"	12.180
		1-7663096	LETTER "N"	12.180
		1-7663097	LETTER "T"	12.180
		1-7663098	LETTER "I"	12.180
		1-7663099	LETTER "A"	12.180
		1-7663100	LETTER "C"	12.180
		9-9419764	NUT	12.180
10.		4229661	MLDG. PKG., (Painted).	12.180
		7-#8-18 x 3/8"	SCREW	N.S.
11.		7648445	EXT., At Lamp	12.940
		4-1/4"-20 x 1-3/16"	SCREW	N.S.

**WOOD GRAINED TRANSFER MATERIAL—
TAIL GATE—10.354**

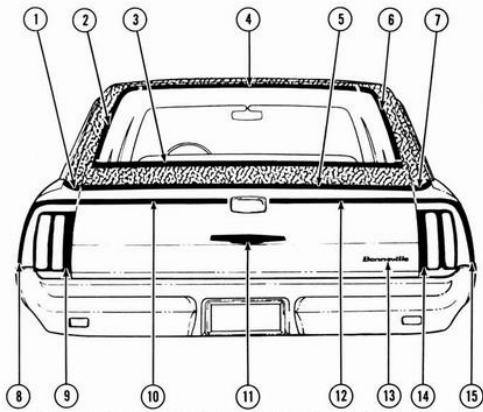

**1967 BONNEVILLE STATION WAGON
REAR END VIEW
6245**

Key	Qty.	Part No.	Name	Group No.
1.		3914081	MLDG. PKG., Belt	12.180
	2-	7656440	CLIP	12.180
	1-	#8-18 x 3/8"	SCREW	N.S.
2.		4468439	MOLDING, Side	12.180
	3-	#8-18 x 1/4"	SCREW	N.S.
3.		4470736	MOLDING, Lower.	12.180
	6-	4491306	CLIP	12.180
4.		4468416	MOLDING, Upper	12.180
	4-	#8-18 x 1/4"	SCREW	N.S.
5.		4229554	MLDG. PKG., Belt	12.180
	6-	7657696	CLIP	12.180
	2-	7657426	CLIP	12.180
	2-	#8-32 x 7/32"	SCREW	N.S.
6.		4468438	MOLDING, Side	12.180
	3-	#8-18 x 1/4"	SCREW	N.S.
7.		3914082	MLDG. PKG., Belt	12.180
	2-	7656440	CLIP	12.180
	1-	#8-18 x 3/8"	SCREW	N.S.
8.		4229646	MLDG. PKG., Rear	12.116
	1-	9777690	CLIP PKG.	12.118
9.		7648446	EXT., At Lamp	12.940
	4-	1/4"-20 x 1-3/16"	SCREW	N.S.
10.		4229656	MLDG. PKG., Lower	12.180
	1-	9777692	CLIP PKG.	12.180
11.		7657800	EMBLEM	12.180
	3-	9419764	NUT	8.921
12.		4229656	MLDG. PKG., Lower	12.180
	1-	9777692	CLIP PKG.	12.180
13.		7666750	PLATE, "Bonneville"	12.180
	3-	3/32" I.D. x 13/64" O.D. x 1/16"	WASHER	N.S.
	3-	9419763	NUT	8.921
14.		7648445	EXT., At Lamp	12.940
	4-	1/4"-20 x 1-3/16"	SCREW	N.S.
15.		4229645	MLDG. PKG., Rear	12.116
	1-	9777690	CLIP PKG.	12.118

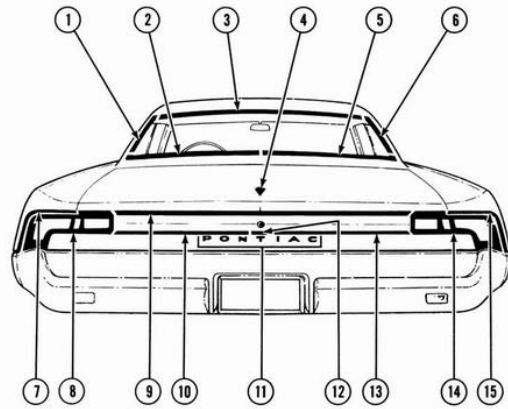

**1967 EXECUTIVE 4-DOOR HARDTOP
REAR END VIEW
TYPICAL OF 39 STYLES (5639 SHOWN)**

Key	Qty.	Part No.	Name	Group No.
1.		7649795	MOLDING, B/Wind. - Side	11.208
	3-	7693140	CLIP	11.209
	2-	7660796	SPACER	11.209
2.		7648031	MOLDING, B/Wind. - Lower.	11.208
	4-	7693140	CLIP	11.209
	1-	7660796	SPACER	11.209
3.		7648026	MOLDING, B/Wind. - Upper	11.208
	6-	7693140	CLIP	11.209
	3-	7660796	SPACER	11.209
4.		7663791	EMBLEM, Lid	12.182
	2-	5/32" I.D. x 1/2" O.D. x 3/16"	WASHER	N.S.
	2-	7616775	NUT	12.183
5.		7648030	MOLDING, B/Wind. - Lower	11.208
	4-	7693140	CLIP	11.209
	1-	7660796	SPACER	11.209
6.		7649794	MOLDING, B/Wind. - Side	11.208
	3-	7693140	CLIP	11.209
	2-	7660796	SPACER	11.209
7.		4229625	MLDG. PKG., Paint	12.116
	1-	9777683	CLIP PKG.	12.118
8.		5958781	BEZEL, T/Lamp	2.681
9.		4229628	MLDG. PKG., Rear End	12.182
	1-	9777685	CLIP PKG.	12.183
10.		4229629	MLDG. PKG., Lower	12.182
	1-	9777685	CLIP PKG.	12.183
11.		1-7663126	LETTER "P"	12.182
	1-7663127	LETTER "O"	12.182	
	1-7663128	LETTER "N"	12.182	
	1-7663129	LETTER "T"	12.182	
	1-7663130	LETTER "I"	12.182	
	1-7663131	LETTER "A"	12.182	
	1-7663132	LETTER "C"	12.182	
	14-	3/32" I.D. x 13/64" O.D. x 1/16"	WASHER	N.S.
	14-	9419763	NUT	12.183
12.		7677697	ESCUTCHEON	12.182
13.		4229629	MLDG. PKG., Lower	12.182
	1-	9777685	CLIP PKG.	12.183
14.		5958782	BEZEL, T/Lamp	2.681
15.		4229624	MLDG. PKG., Paint	12.116
	1-	9777683	CLIP PKG.	12.118

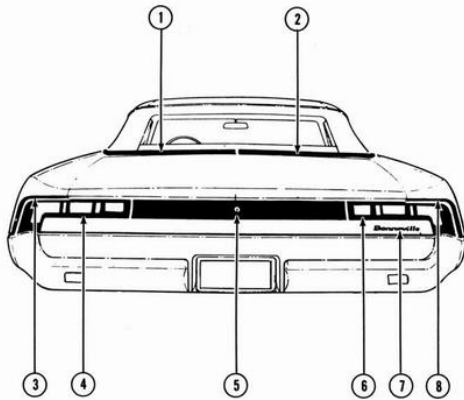

**1967 BONNEVILLE CONVERTIBLE COUPE
REAR END VIEW
TYPICAL OF 67 STYLES (6267 SHOWN)**

Key	Qty.	Part No.	Name	Group No.
1.		3917769	MLDG. PKG., Finish	12.116
		6-7672609	CLIP	12.118
		3-#8-18 x 1/4"	SCREW	N.S.
2.		3917770	MLDG. PKG., Finish	12.116
		6-7672709	CLIP	12.118
		3-#8-18 x 1/4"	SCREW	N.S.
3.		4229623	MLDG. PKG., Paint	12.116
		1-9777683	CLIP PKG.	12.118
4.		5958783	BEZEL, T/Lamp	2.681
5.		4229627	MLDG. PKG., Rear End	12.182
		1-9777684	CLIP PKG.	12.183
6.		5958784	BEZEL, T/Lamp	2.681
7.		7666750	PLATE, "Bonneville"	12.182
		3-3/32" I.D. x 13/64" O.D. x 1/16"	WASHER	N.S.
		3-9419763	NUT	12.183
8.		4229622	MLDG. PKG., Paint	12.116
		1-9777683	CLIP PKG.	12.118

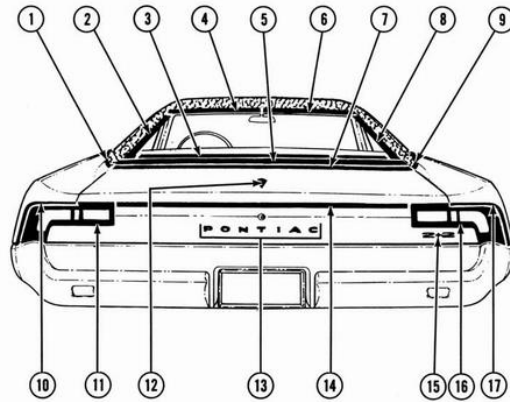

**1967 CATALINA 2-DOOR SPORT COUPE
REAR END VIEW TYPICAL OF 87 STYLES
(5287 SHOWN W/2 + 2 OPTION)**

Key	Qty.	Part No.	Name	Group No.
1.		7649285	MOLDING, Belt.	12.116
		3-7731589	CLIP	12.118
		1-7669079	CLIP	12.118
		1-9419764	NUT	12.118
2.		7647559	MOLDING, B/Wind. - Side	11.208
		4-7639528	CLIP	11.209
		2-7660796	SPACER	11.209
3.		7660862	MOLDING, B/Wind. - Lower	11.208
		8-7639528	CLIP	11.209
		8-7664118	SPACER	11.209
4.		7646718	MOLDING, B/Wind. - Upper	11.208
		5-7639528	CLIP	11.209
		2-7660796	SPACER	11.209
5.		4229644	MLDG. PKG., Paint	12.182
		1-9777689	CLIP PKG.	12.183
6.		7646717	MLDG., B/Wind. - Upper	11.208
		5-7639528	CLIP	11.209
		2-7660796	SPACER	11.209
7.		4229643	MLDG. PKG., Belt	12.182
		1-9777688	CLIP PKG.	12.183
8.		7647558	MOLDING, B/Wind. - Side	11.208
		4-7639528	CLIP	11.209
		2-7660796	SPACER	11.209
9.		7649284	MOLDING, Belt.	12.116
		3-7731589	CLIP	12.118
		1-7669079	CLIP	12.118
		1-9419764	NUT	12.118
10.		4229625	MLDG. PKG., Paint	12.116
		1-9777683	CLIP PKG.	12.118
11.		5958781	BEZEL, T/Lamp	2.681
12.		7663784	EMBLEM, Lid	12.182
		2-5/32" I.D. x 1/2" O.D. x 3/16"	WASHER	N.S.
		2-7616775	NUT	12.183
13.		1-7663126	LETTER "P"	12.182
		1-7663127	LETTER "O"	12.182
		1-7663128	LETTER "N"	12.182
		1-7663129	LETTER "T"	12.182
		1-7663130	LETTER "I"	12.182
		1-7663131	LETTER "A"	12.182
		1-7663132	LETTER "C"	12.182
		14-3/32" I.D. x 13/64" O.D. x 1/16"	WASHER	N.S.
		14-9419763	NUT	12.183
14.		4229628	MLDG. PKG., Rear End	12.182
		1-9777685	CLIP PKG.	12.183
15.		7663982	PLATE, "2+2"	12.182
		2-3/32" I.D. x 13/64" O.D. x 1/16"	WASHER	N.S.
		2-9419763	NUT	12.183
16.		5958782	BEZEL, T/Lamp	2.681
17.		4229624	MLDG. PKG., Paint	12.116
		1-9777683	CLIP PKG.	12.118

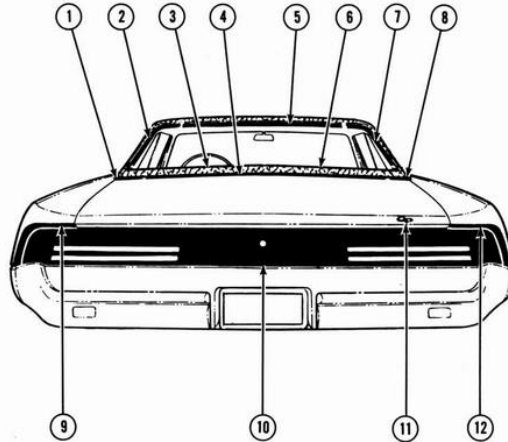

1967 GRAND PRIX 2-DOOR SPORT COUPE 6657 REAR END VIEW

Key Qty.	Part No.	Name	Group No.	Key Qty.	Part No.	Name	Group No.
1.	7648715	MOLDING, Belt	12.116	7.	4478791	MOLDING, B/Wind. - Side	11.208
	4-7731589	CLIP	12.118		4-7639528	CLIP	11.209
	1-7669079	CLIP	12.118		2-4531604	SPACER	11.209
	1-9419764	NUT	12.118				
2.	4478792	MOLDING, B/Wind. - Side	11.208	8.	7648714	MOLDING, Belt.	12.116
	4-7639528	CLIP	11.209		4-7731589	CLIP	12.118
	2-4531604	SPACER	11.209		1-7669079	CLIP	12.118
					1-9419764	NUT	12.118
3.	7647142	MOLDING, B/Wind. - Lower	11.208	9.	4229640	MLDG. PKG., Paint	12.116
	4-7693140	CLIP	11.209		1-9777686	CLIP PKG.	12.118
	3-4531604	SPACER	11.209				
4.	7648705	MOLDING, Belt	12.121	10.	4229642	MLDG. PKG., Paint	12.182
	9-7587044	CLIP	12.118		1-9777687	CLIP PKG.	12.183
5.	4477724	MOLDING, B/Wind. - Upper.	11.208	11.	7657958	PLATE, "GP"	12.182
	6-7639528	CLIP	11.209		2-3/32" I.D. x 13/64" O.D. x 1/16" . .	N.S.	
	3-4531604	CLIP	11.209		2-9421827	NUT	8.921
6.	7647141	MOLDING, B/Wind. - Lower	11.208	12.	4229639	MLDG. PKG., Paint	12.116
	4-7693140	CLIP	11.209		1-9777686	CLIP PKG.	12.118
	3-4531604	SPACER.	11.209				

CLIP PACKAGE CONTENTS ARE IDENTIFIED IN THE FOLLOWING LIST.
 ALL COMPONENTS ARE AVAILABLE FOR SEPARATE SERVICE EXCEPT THOSE ITEMS MARKED NOT SERVICED (N.S.)

Part No.	Qty.	Name	Group No.	Part No.	Qty.	Name	Group No.
9777680	CLIP PKG.		12.118	9777691	CLIP PKG.		12.180
	2-7601223	CLIP	12.118		5-4887056	WASHER	12.180
	3-7657720	CLIP	12.118		2-9419766	NUT	8.921
	2-7707800	SCREW	N.S.		2-9421827	NUT	8.921
9777681	CLIP PKG.		12.118	9777692	CLIP PKG.		12.180
	2-7648305	CLIP	12.118		1-4871644	SCREW	N.S.
	5-7656277	CLIP	12.118		4-4894059	CLIP	12.118
	2-7707799	SCREW	N.S.		1-7649377	CLIP	12.183
	5-4492963	SCREW	11.209	9777693	CLIP PKG.		12.118
9777682	CLIP PKG.		12.118		4-4879431	SCREW	N.S.
	5-4403445	CLIP	12.118		4-7657089	CLIP	12.118
	2-4490167	CLIP	12.118	9777694	CLIP PKG.		12.118
	2-7707850	WASHER	N.S.		1-4490167	CLIP	12.118
9777683	CLIP PKG.		12.118		1-4490959	SCREW	N.S.
	1-4411604	SCREW	N.S.		4-7674304	CLIP	12.118
	2-4887056	WASHER	12.180		1-7645439	SCREW	N.S.
	2-9419763	NUT	8.921	9777695	CLIP PKG.		12.118
9777684	CLIP PKG.		12.183		1-4490167	CLIP	12.118
	4-4871098	WASHER	11.209		4-7674304	CLIP	12.118
	4-7616775	NUT	12.118		1-7645439	SCREW	N.S.
9777685	CLIP PKG.		12.183	9777696	CLIP PKG.		12.118
	6-7715545	WASHER	12.183		4-4777622	CLIP	12.118
	6-9419763	NUT	8.921		1-7666748	CLIP	12.118
	6-4501682	WASHER	2.688		1-7666749	CLIP	12.118
					2-7681463	SCREW	12.118
9777686	CLIP PKG.		12.118	9777697	CLIP PKG.		12.118
	1-4411604	SCREW	N.S.		1-4490167	CLIP	12.118
	2-4485531	WASHER	12.180		5-7674304	CLIP	12.118
	2-7616775	NUT	12.118		1-7645439	SCREW	N.S.
9777687	CLIP PKG.		12.183	9777698	CLIP PKG.		12.118
	16-4871098	WASHER	11.209		3-4879432	SCREW	N.S.
	16-7616775	NUT	12.118		4-7653468	CLIP	12.118
					4-4492963	SCREW	11.209
9777688	CLIP PKG.		12.183	9777699	CLIP PKG.		12.118
	2-4532762	SCREW	N.S.		2-4528486	NUT	8.176
	2-4825958	CLIP	12.118		2-7694070	WASHER	N.S.
	5-7587044	CLIP	12.118	9777700	CLIP PKG.		12.118
	5-4492963	SCREW	11.209		1-4409925	SCREW	10.096
9777689	CLIP PKG.		12.183		2-7699439	CLIP	12.118
	7-4877816	NUT	12.183		2-9419764	NUT	8.921
	7-7583551	WASHER	12.183	9777701	CLIP PKG.		12.183
9777690	CLIP PKG.		12.118		6-4532762	SCREW	N.S.
	1-4879432	SCREW	N.S.		6-7658311	CLIP	12.183
	1-4894059	CLIP	12.118				
	3-7584569	CLIP	11.032				

Part No.	Qty.	Name	Group No.	Part No.	Qty.	Group No.
9777702		CLIP PKG.	12.118	9777709		CLIP PKG. 8.148
		4-4879432 SCREW	N.S.			2-9784505 CLIP. 8.148
		4-7657089 CLIP.	12.118			2-9419751 NUT. 8.921
						4-4403445 CLIP. 12.118
9777703		CLIP PKG.	12.118	9777710		CLIP PKG. 8.309
		9-4403445 CLIP.	12.118			1-9417943 SCREW N.S.
		1-4817162 CLIP.	12.118			1-9426567 SCREW 8.977
		1-7584569 CLIP.	11.032			1-9781633 NUT 8.309
		1-9419763 NUT.	8.921			6-9777746 RETAINER. 8.309
						6-9414722 SCREW 8.977
9777704		CLIP PKG.	12.118			2-9777756 RETAINER. 8.309
		13-4403445 CLIP	12.118			2-9422601 SCREW N.S.
		1-4817162 CLIP	12.118			1-9781949 SPACER 8.309
		1-7584569 CLIP	11.032			
		1-9419763 NUT	8.921	9777711		CLIP PKG. 8.148
						2-7658109 CLIP. 8.148
9777705		CLIP PKG.	12.180			2-4461935 SCREW 12.118
		2-7669079 BOLT	12.118			
		5-7584569 CLIP	11.032	9777712		CLIP PKG. 8.309
		2-9419764 NUT	8.921			5-588546 SCREW 8.148
						6-9414722 SCREW 8.977
9777706		CLIP PKG.	12.118			2-9788246 RETAINER. 8.309
		1-120391 WASHER	N.S.			1-9419763 NUT. 8.921
		2-4490167 CLIP	12.118			1-9788267 RETAINER. 8.309
		2-7681464 SCREW	N.S.			2-9777756 RETAINER. 8.309
						2-9422601 SCREW N.S.
						2-9789899 SPACER 8.309
9777707		CLIP PKG.	12.118	9777713		CLIP PKG. 8.148
		1-4446130 SCREW	N.S.			6-7657719 CLIP. 8.148
		8-7674304 CLIP.	12.118			2-4837349 CLIP. 12.118
						2-4837002 NUT. 12.118
9777708		CLIP PKG.	8.309	9777714		CLIP PKG. 8.148
		1-9417943 SCREW	N.S.			4-9788394 CLIP 8.148
		1-9781633 NUT	8.309			2-9784505 CLIP 8.148
		2-9788243 RETAINER.	8.309			2-9419751 NUT 8.921
		1-9419763 NUT	8.921	9789946		CLIP PKG. 8.176
		6-9777736 RETAINER.	8.309			4-4843565 NUT. 12.183
		6-9414722 SCREW	8.977			4-9788265 STUD 8.176
		1-9426567 SCREW	8.977			
		2-9777756 RETAINER.	8.309			
		2-9422601 SCREW	N.S.			
		1-9781949 SPACER	8.309			

