

# DELCO-MORAINE POWER BRAKE

## CONTENTS OF THIS SECTION

SUBJECT	PAGE	SUBJECT	PAGE
General Description . . . . .	5A-1	Power Brake and Master Cylinder	
Design . . . . .	5A-1	Assembly--Remove . . . . .	5A- 6
Principles of Operation . . . . .	5A-2	Over-all Brake Unit--Disassemble . . . . .	5A- 6
Released Position . . . . .	5A-2	Power Piston Assembly--Disassemble . . . . .	5A- 7
Applying Position . . . . .	5A-3	Master Cylinder--Disassemble . . . . .	5A- 8
Holding Position . . . . .	5A-3	Inspection--Cleaning . . . . .	5A- 8
Releasing . . . . .	5A-4	Brake Assembly--Assemble . . . . .	5A- 8
Vacuum Failure . . . . .	5A-4	Master Cylinder--Assemble . . . . .	5A- 9
Checks and Adjustments on Car . . . . .	5A-5	Power Piston--Assemble . . . . .	5A- 9
Minor Repairs . . . . .	5A-5	Push Rod Adjustment . . . . .	5A-12
Bleeding Brakes . . . . .	5A-5	Power Brake Assembly--Install . . . . .	5A-12
Stop Light Switch--Remove and Replace . . . . .	5A-5	System Tests . . . . .	5A-12
Overhaul Delco-Moraine Power Brake . . . . .	5A-6	Trouble Diagnosis . . . . .	5A-13
Master Cylinder Only--Remove . . . . .	5A-6		

## GENERAL DESCRIPTION

The Delco Moraine Power Brake Unit is a combined vacuum and hydraulic unit which utilizes engine intake-manifold vacuum and atmospheric pressure to provide power-assisted application of vehicle brakes. The Unit takes the place of a conventional brake system's master cylinder. From the master cylinder connection outward to the wheel units, there is no other change in the brake system. In addition to the master cylinder connections, the Unit requires a vacuum connection to the engine intake-manifold (through a vacuum check valve) and a mechanical connection to the brake pedal. The Unit is self-contained with no external rods or levers exposed to dirt or moisture.

The Power Brake Unit provides lighter pedal pressures. These lighter pedal pressures are obtained with reduced pedal travel, making it possible to bring the brake pedal down to the approximate height of the accelerator pedal when at closed throttle position. Thus, the driver, after closing the throttle, can shift his toe from one pedal to the other without lifting his heel from the floor.

The vacuum check valve permits several applications of the Power Brake Unit with vacuum assist after the engine has stopped or because of any other loss of vacuum. After the vacuum stored in the Unit has been lost, or in case of vacuum failure at the

Unit or its vacuum connections, the brakes can be applied in the conventional manner. Since the vacuum assist is not available, the pedal pressure will be higher.

## DESIGN

The Unit is composed of two main sections: the vacuum power cylinder, and the hydraulic master cylinder.

The vacuum power cylinder contains the power piston assembly which houses the control valve and reaction mechanism, and power piston return spring. The control valve is composed of the air valve and floating control valve assembly. The control valve is operated by a push rod that projects through the end of the power cylinder housing. An air filter element is assembled around the push rod and fills the cavity inside the hub of the power piston. A rubber boot protects the air filter. The reaction mechanism consists of a hydraulic piston reaction plate and a series of levers. A vacuum check valve assembly is mounted in the front housing assembly for connection to the vacuum source.

A fluid reservoir is integrally cast with the master cylinder and supplies fluid to the space between the primary and secondary seals through a hole in the casting.

Connection is made to the wheel cylinder through the hydraulic outlet and a conventional check valve.

## PRINCIPLES OF OPERATION

### RELEASED POSITION (Fig. 5A-1)

A line from the engine intake-manifold is connected to the vacuum check valve in the front housing of the power brake. The check valve is to prevent loss of vacuum when manifold vacuum falls below that in the power brake system.

In the released position the air valve is seated on the floating control valve. Air under atmospheric pressure, which enters through the filter element in the tube extension of the power piston, is shut off at the floating control valve. The vacuum, which is present at all times in the space to the left of the power piston, is free to evacuate any existing air on the right side of the power piston. This air is drawn over the floating control valve seat and through two small passages in the power piston then into the

space at the left of the power piston. It is then drawn through the check valve to the vacuum source.

In this position there is vacuum on both sides of the power piston, which is held against the rear housing by the piston return spring. At rest, the hydraulic reaction plate and the reaction levers are held back against the reaction retainer by the air valve spring. The air valve return spring holds the air valve back so its retaining ring rests against the power piston.

The floating control valve assembly is held against the air valve seat by the control valve spring.

In this position, the by-pass hole in the hydraulic master cylinder is open to the reservoir and fluid can flow freely in either direction between the hydraulic cylinder and the fluid reservoir.

A residual pressure is maintained in the brake lines by the hydraulic check valve and its spring in the master cylinder.

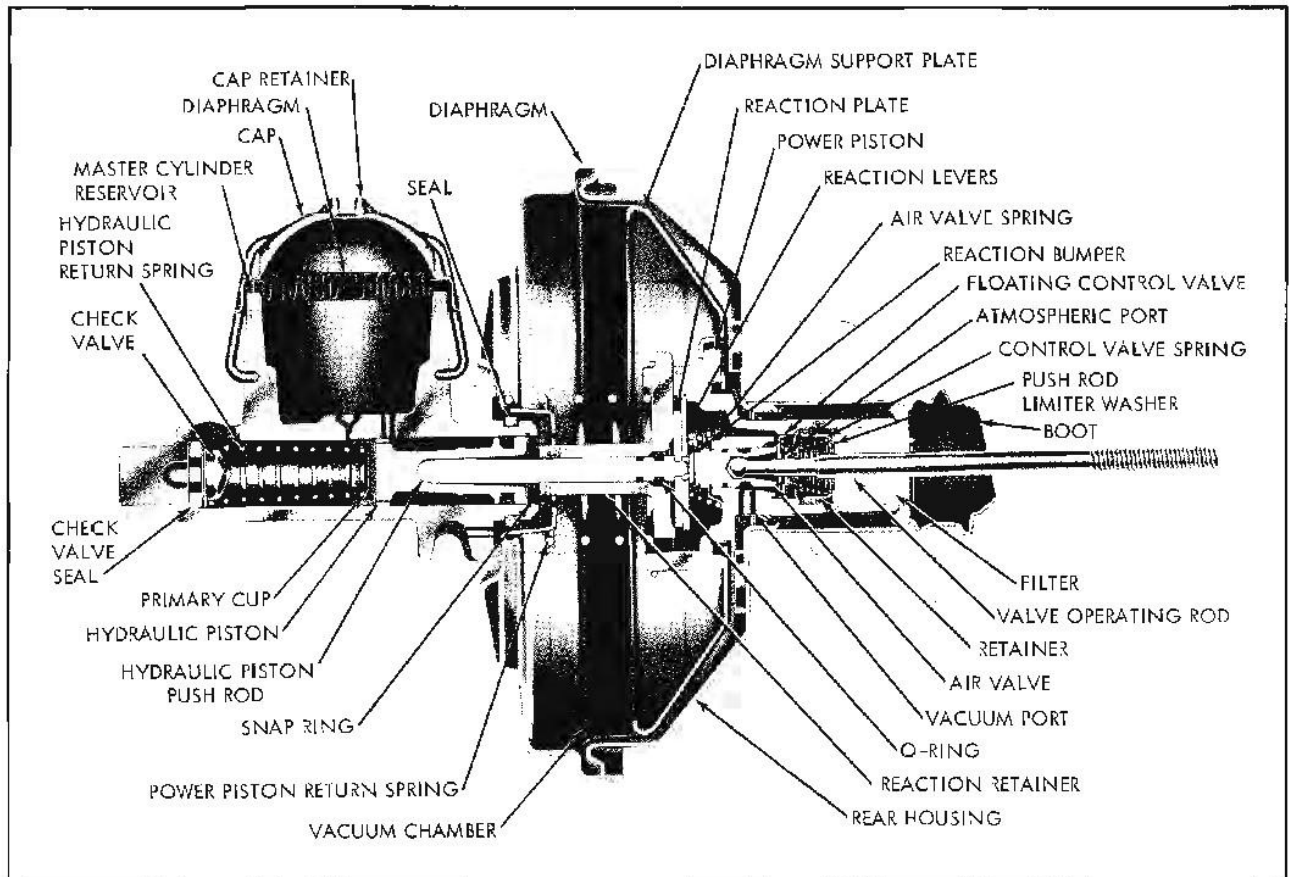

Fig. 5A-1 Released Position

**APPLYING POSITION (Fig. 5A-2)**

As the pedal is depressed, the push rod carries the air valve away from the floating control valve. The floating control valve will follow until it is in contact with the raised seat in the power piston. When this occurs, the vacuum is shut off to the right hand side of the power piston, and air under atmospheric pressure rushes through the air filter and travels past the seat of the air valve and through two passageways into the housing on the right of the power piston.

Since there is still vacuum on the left side of the power piston, the force of the air at atmospheric pressure on the right of the piston will force the power piston to travel to the left.

As the power piston travels to the left, the piston rod carries the master cylinder piston into the bore of the master cylinder. As the master cylinder piston primary cup passes the by-pass hole, hydraulic pressure starts to build up in the hydraulic system.

As the pressure builds up on the end of master cylinder piston, the hydraulic reaction plate is moved off its seat on the reaction retainer and presses against the reaction levers.

The levers, in turn, swing about their pivots and bear against the end of the air valve-push rod assembly.

In this manner, approximately 30% of the load on the piston is transferred back through the reaction system to the brake pedal. This gives the operator a feel which is proportional to the degree of brake application.

**HOLDING POSITION (Fig. 5A-3)**

When the desired pedal pressure is reached, the power piston moves to the left until the floating control valve, which is still seated on the power piston, again seats on the air valve. The power brake will now remain stationary, until either pressure is applied or released at the brake pedal.

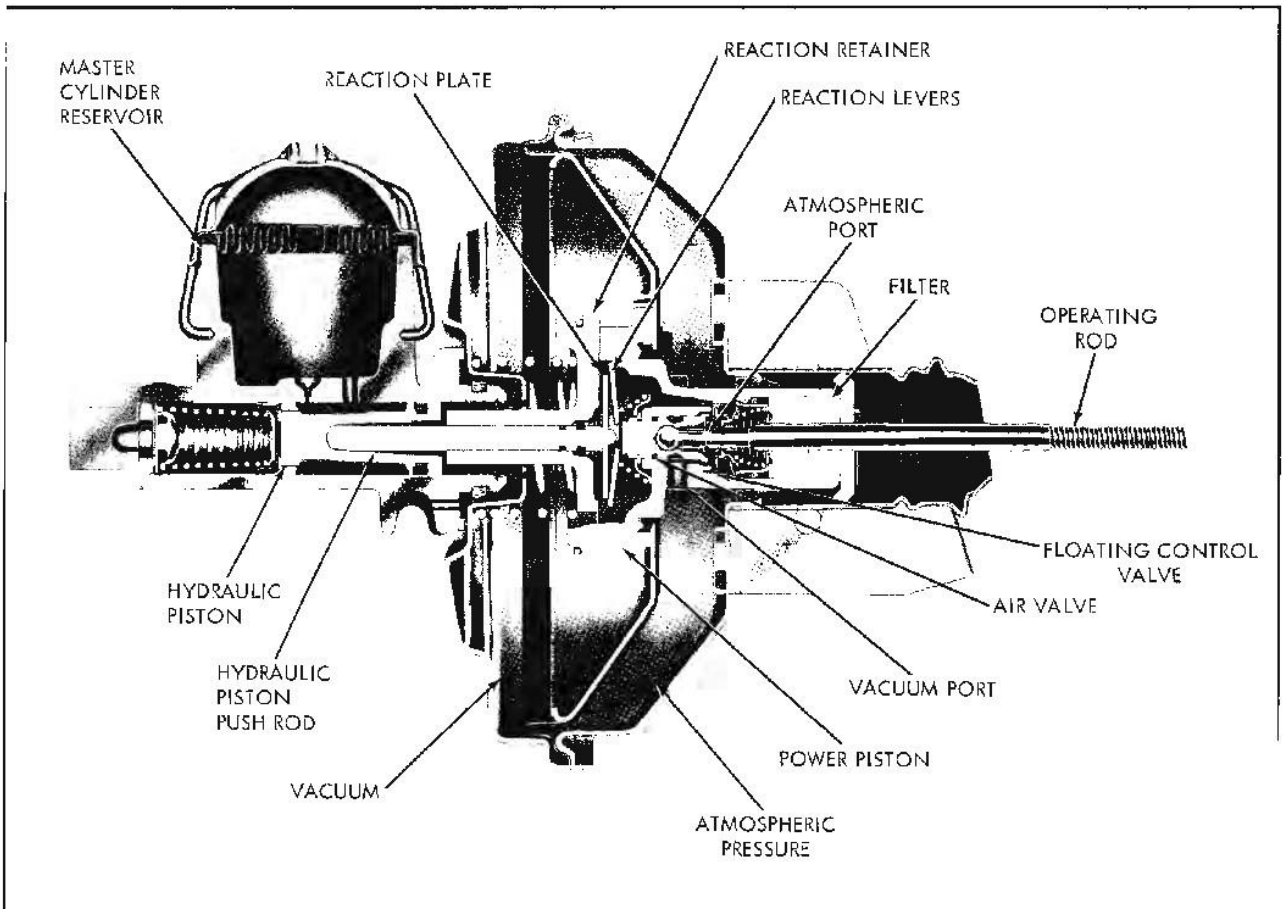

Fig. 5A-2 Applying Position

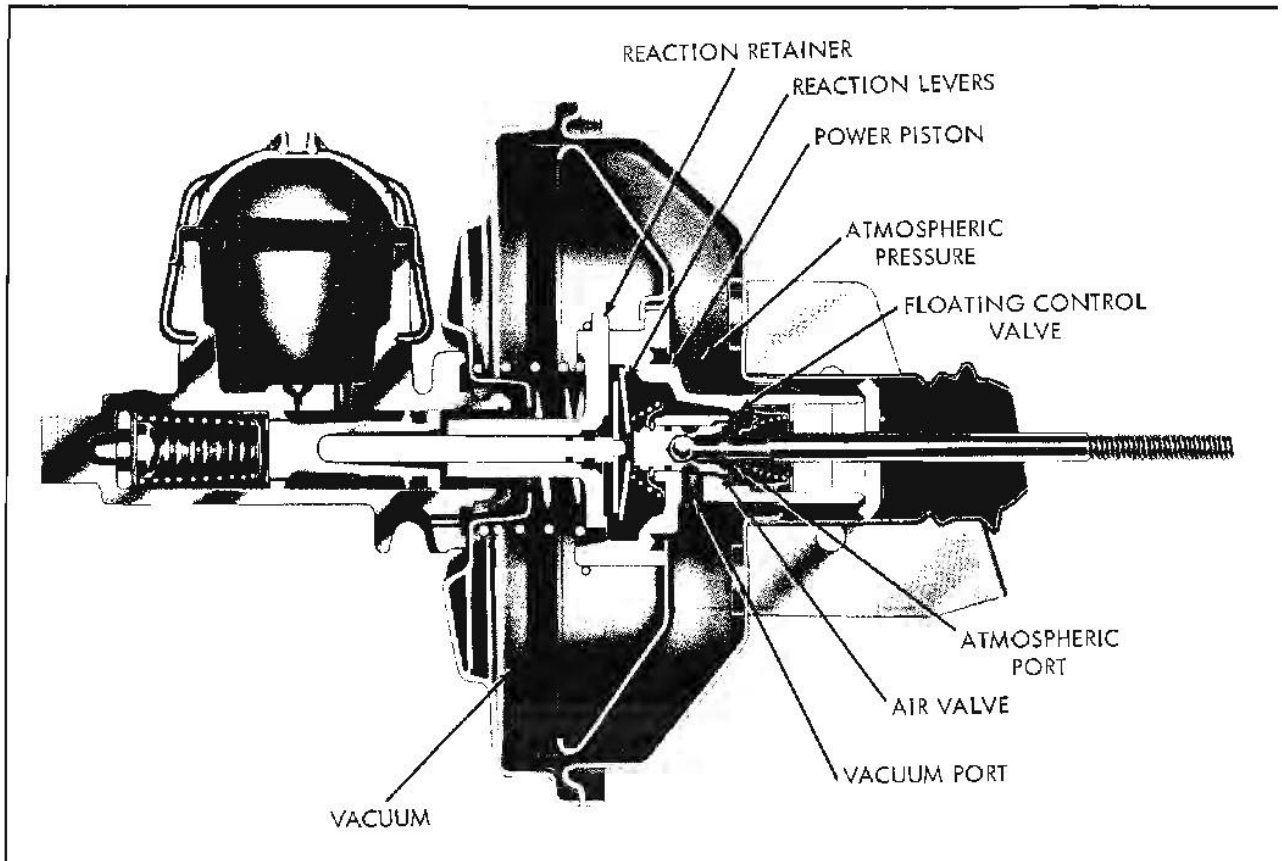

Fig. 5A-3 Holding Position

**RELEASING (Fig. 5A-4)**

As the pressure at the pedal is released, the air valve spring forces the air valve back until its snap ring rests against the power piston. As it returns, the air valve pushes the floating control valve off its seat on the power piston.

The air valve, seating on the floating control valve has shut off the outside air source. When it lifts the floating control valve from its seat on the power piston, it opens the space to the right of the power piston to the vacuum source.

Since both sides of the power piston are now under vacuum, the power piston return spring will return the piston to its released position against the rear housing. As the power piston is returned, the hydraulic master cylinder piston moves back, and the fluid from the wheel cylinders flows back into the master cylinder around the check valve.

If the brake pedal is released quickly, the master cylinder piston immediately returns to the released

position. If the fluid in the lines cannot return as quickly as the piston, compensation is provided for by the flow of fluid from the space between the primary cup and the secondary seal through the holes in the piston. The excess fluid in the system can flow back to the fluid reservoir through the small by-pass hole in the master cylinder bore after the brake is released.

**VACUUM FAILURE**

In case of vacuum source interruption, as the pedal is pushed down, the end of the air valve contacts the reaction levers and forces them, in turn, against the hydraulic reaction plate. Since the hydraulic reaction plate is fastened to the piston rod, it forces the piston rod against the master cylinder piston, which builds up the hydraulic line pressure.

The pedal pressure required for a manual application, such as described, is considerably greater than with vacuum-assist.

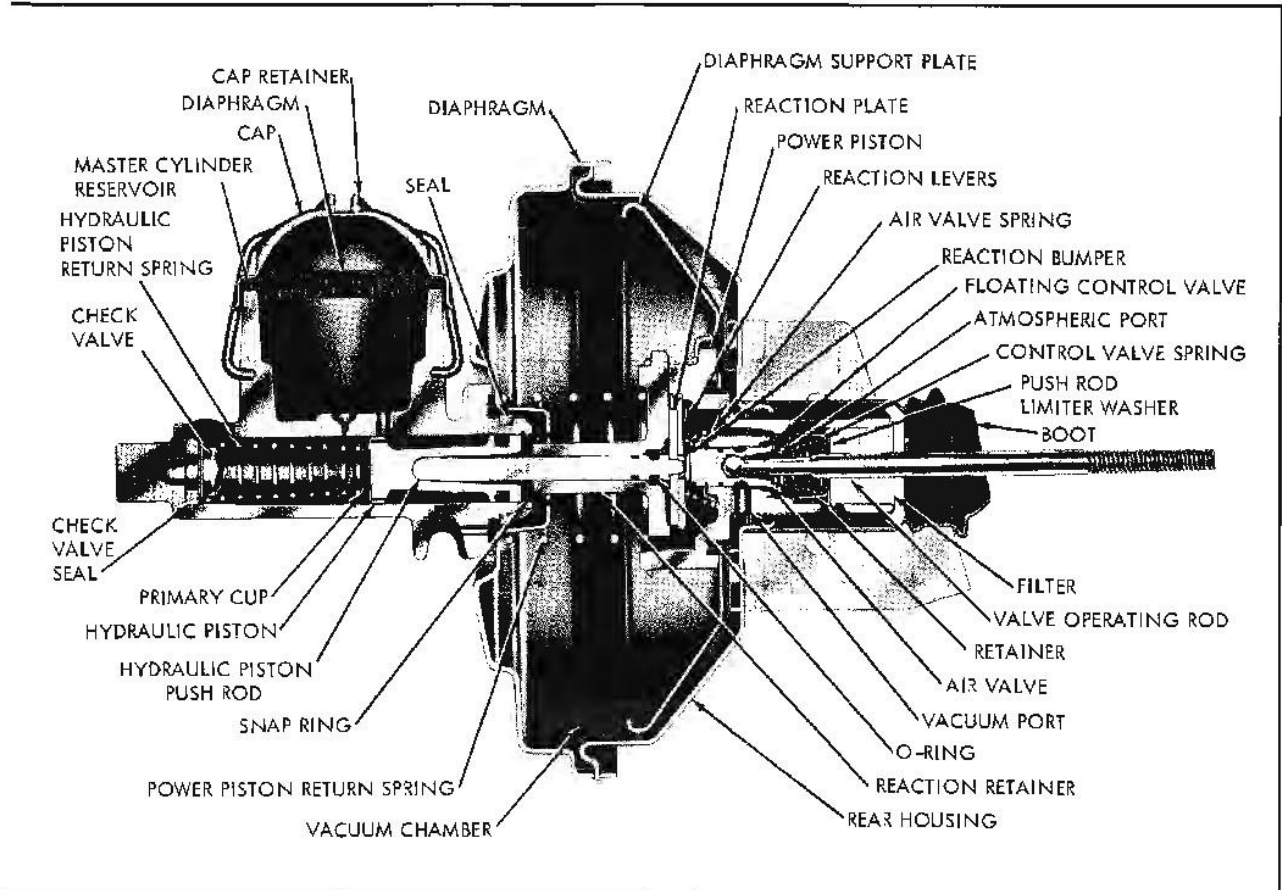

Fig. 5A-4 Releasing

**CHECKS AND ADJUSTMENTS ON CAR**

1. Check for free operation of brake pedal. If binding exists, check pivot points for binding and lubricate as required.
2. Check stop light switch for proper setting and operation.
3. Check fluid level in hydraulic cylinder reservoir. Fluid level should be 1/2" from top of filler opening.
4. Check vacuum line and connections between carburetor and vacuum power cylinder for possible vacuum leaks.
5. Check engine for good stall-free idle. Correct as required.

**MINOR REPAIRS**

**BLEEDING BRAKES**

Brakes should be bled in the same manner as standard brakes.

**STOP LIGHT SWITCH—REMOVE AND REPLACE**

**REMOVE**

1. Disconnect switch wires by removing plug at stop light switch.
2. Remove switch by screwing out of bracket.

**REPLACE**

1. Position stop light switch in bracket and screw into maximum distance.
2. Brake pedal arm moves switch to correct distance on rebound. Check if pedal is in full return position by lifting slightly by hand.
3. Connect switch wires by inserting plug on switch.

**OVERHAUL DELCO-MORAINE POWER BRAKE****MASTER CYLINDER ONLY—REMOVE**

Certain repair operations, such as replacement of master cylinder internal parts, permits the master cylinder to be removed by itself, leaving the power cylinder, pedal and brackets in the car.

1. Remove hydraulic connection from master cylinder, pump fluid from cylinder into a container and dispose of the fluid. Cover cylinder opening and pipe end to exclude dust, dirt, etc.
2. Remove master cylinder attaching nuts and lockwashers and remove master cylinder from vacuum power section.

**POWER BRAKE AND MASTER CYLINDER ASSEMBLY—REMOVE**

1. Disconnect vacuum hose at vacuum check valve. Cover hose and valve opening to exclude dust, dirt, etc. (Fig. 5A-5).

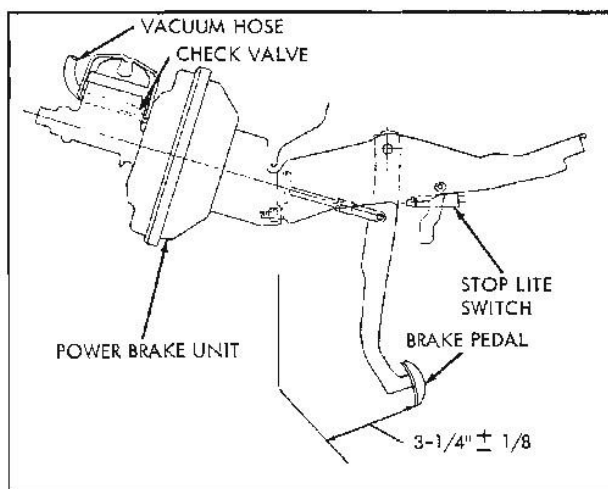

Fig. 5A-5 Simple Schematic of Power Brake System

2. Disconnect pipe from master cylinder hydraulic port and cover cylinder opening and pipe end to exclude dust, dirt, etc.
3. Remove clevis pin from brake pedal inside car.
4. Remove nuts and lockwashers from rear half housing and remove power brake assembly.
5. Clean exterior of power brake assembly and drain reservoir of hydraulic fluid.

**OVER-ALL BRAKE UNIT—DISASSEMBLE**

1. Put power brake unit in a vise, clamping on sides of master cylinder reservoir with push rod up (Fig. 5A-6).
2. Scribe a line across the front and rear housings to facilitate reassembly.
3. Remove clevis and jam nut from push rod.

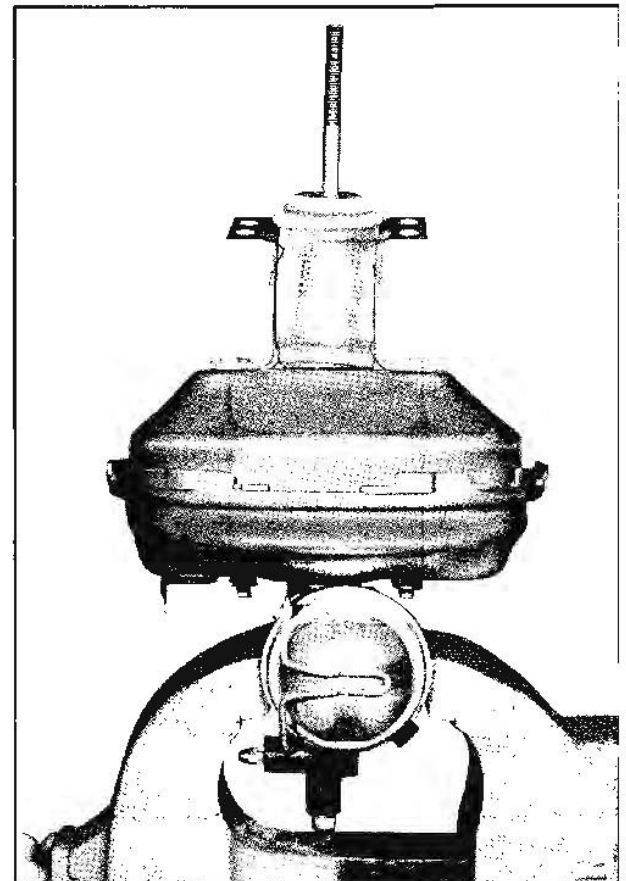

Fig. 5A-6 Brake Unit Mounted in Vise



4. Remove plastic boot and silencer. A small retaining ring on the push rod holds the silencer in place on the push rod.

5. Place a rod in position on rear housing cover and rotate rear half housing counterclockwise to unlock rear half from front housing.

*NOTE: Rotate slowly as housing is under spring load.*

6. Remove rear housing and power piston assembly by lifting straight up slowly and lay it aside on a clean smooth surface (Fig. 5A-7).

7. Remove power piston return spring.

8. Reposition master cylinder in vise. Scribe a line across front housing and master cylinder assembly and remove nuts and lockwashers from master cylinder studs. Remove master cylinder assembly from front housing.

9. Remove front housing seal, vacuum check valve and grommet from front housing (Fig. 5A-8).

#### **POWER PISTON GROUP—DISASSEMBLE** (Fig. 5A-9)

*CAUTION: Care must be taken in handling diaphragm of power piston group. Diaphragm should be guarded against grease, oil and foreign matter and must be protected from nicks or cuts that might be caused by rough surfaces, damaged tools or dropping the piston.*

1. Remove lock ring from power piston by prying from under locking lugs.

2. Remove reaction retainer, piston rod, reaction plate, three reaction levers and air valve spring.

3. Remove small reaction bumper and air valve spring retainer from air valve.

4. Place square end of tool J-21524 in vise holding support plate and power piston with tube end of piston facing up.

5. Pull diaphragm edges away from support plate and position on tool J-21524 so that three lugs on tool fit into three notches in power piston.

6. Press down on support plate and rotate counterclockwise until support plate separates from power piston (Fig. 5A-10).

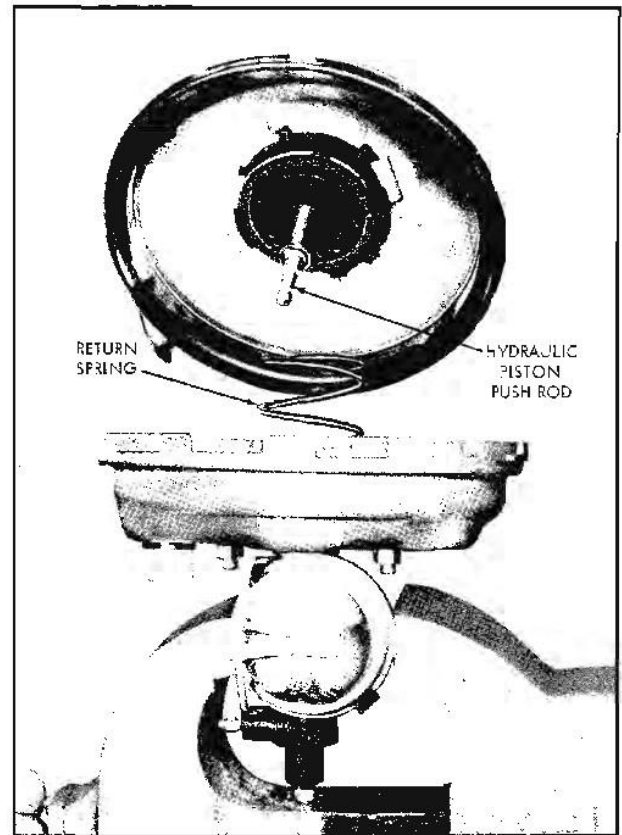

Fig. 5A-7 Removing Rear Housing

7. Remove diaphragm from support plate.

8. Remove silencer from neck of power piston tube.

9. Position power piston with tube end down, in vise padded with shop towels.

*CAUTION: Do not clamp on tube as outside surface of tube acts as bearing surface.*

10. Remove snap ring on air valve using Truarc Pliers and place power piston with tube end down in arbor press.

11. Press air valve from power piston using rod not exceeding 1/2 in. diameter. Removal of valve releases floating control valve, floating valve retainer, push rod limiter washer and air filters (Fig. 5A-11).

*NOTE: The floating control valve must be replaced at assembly with a new valve since force required to remove distorts component parts.*

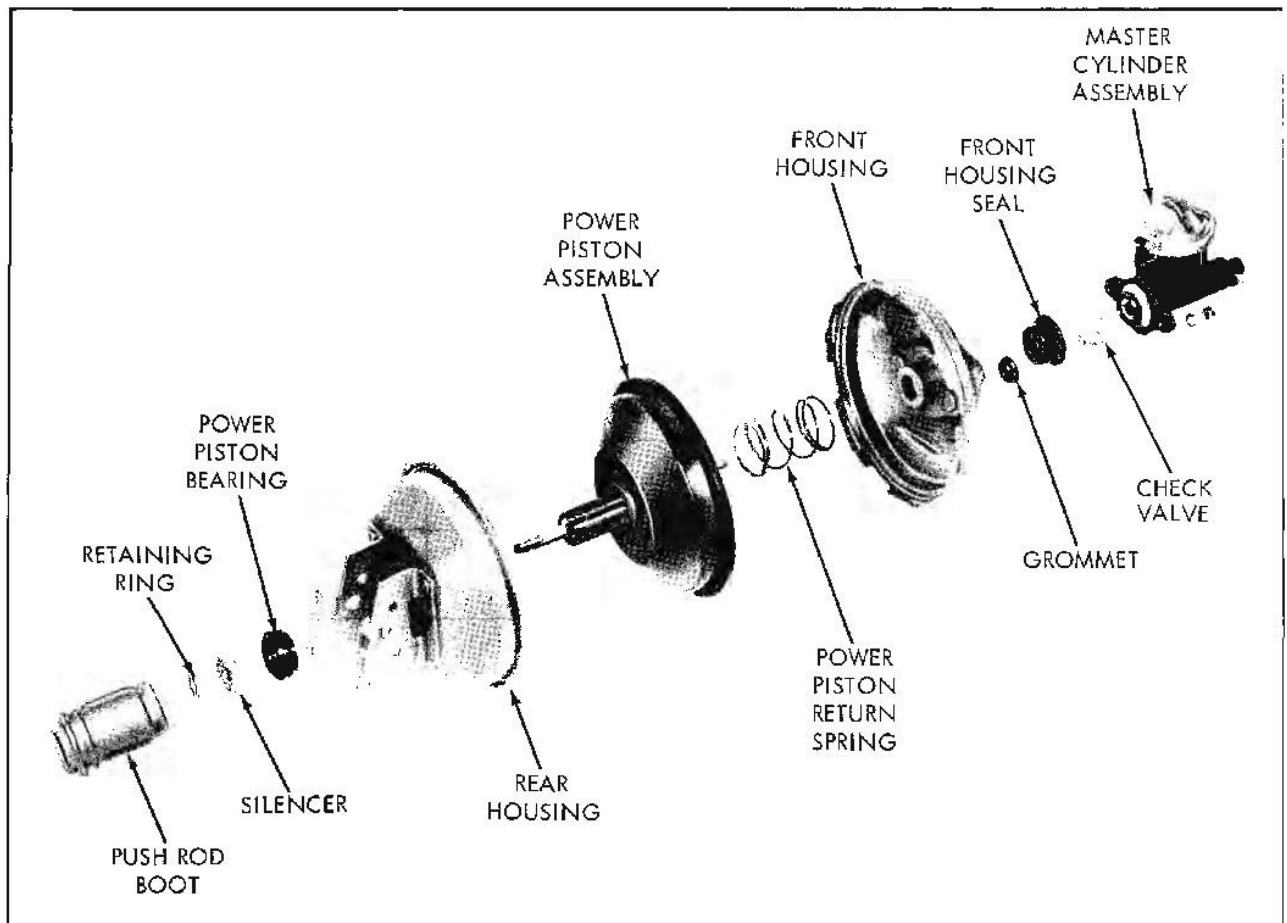

Fig. 5A-8 Power Brake Units - Exploded View

12. Remove master cylinder push rod from center of reaction retainer and two O-rings from grooves in master cylinder piston rod.

#### MASTER CYLINDER DISASSEMBLE (Fig. 5A-12)

1. Remove filter from groove on O.D. of open end of master cylinder.
2. Remove lock ring, master cylinder piston assembly, primary cup, spring and retainer, check valve and check valve washer.
3. From master cylinder piston, remove secondary seal. Check small by-pass holes in end of piston to make sure they are open.
4. Remove filler cap from fluid reservoir and remove master cylinder reservoir diaphragm.

#### INSPECTION—CLEANING

Thoroughly wash all parts in alcohol and air dry. Blow dust and cleaning fluid out of all internal passages. If inside of front housing is slightly scored or scratched, clean with crocus cloth or fine emery cloth. If scratches in front housing cannot be removed, replace housing.

*CAUTION: It is important that all parts be placed on a clean paper or cloth after being cleaned to prevent the possibility of dirt being assembled into unit or grease contacting any rubber parts.*

#### POWER BRAKE ASSEMBLY

Inspect all parts for scoring, pitting, dents or nicks. Small imperfections can be smoothed out with fine emery cloth. Replace if badly nicked, scored or otherwise damaged.



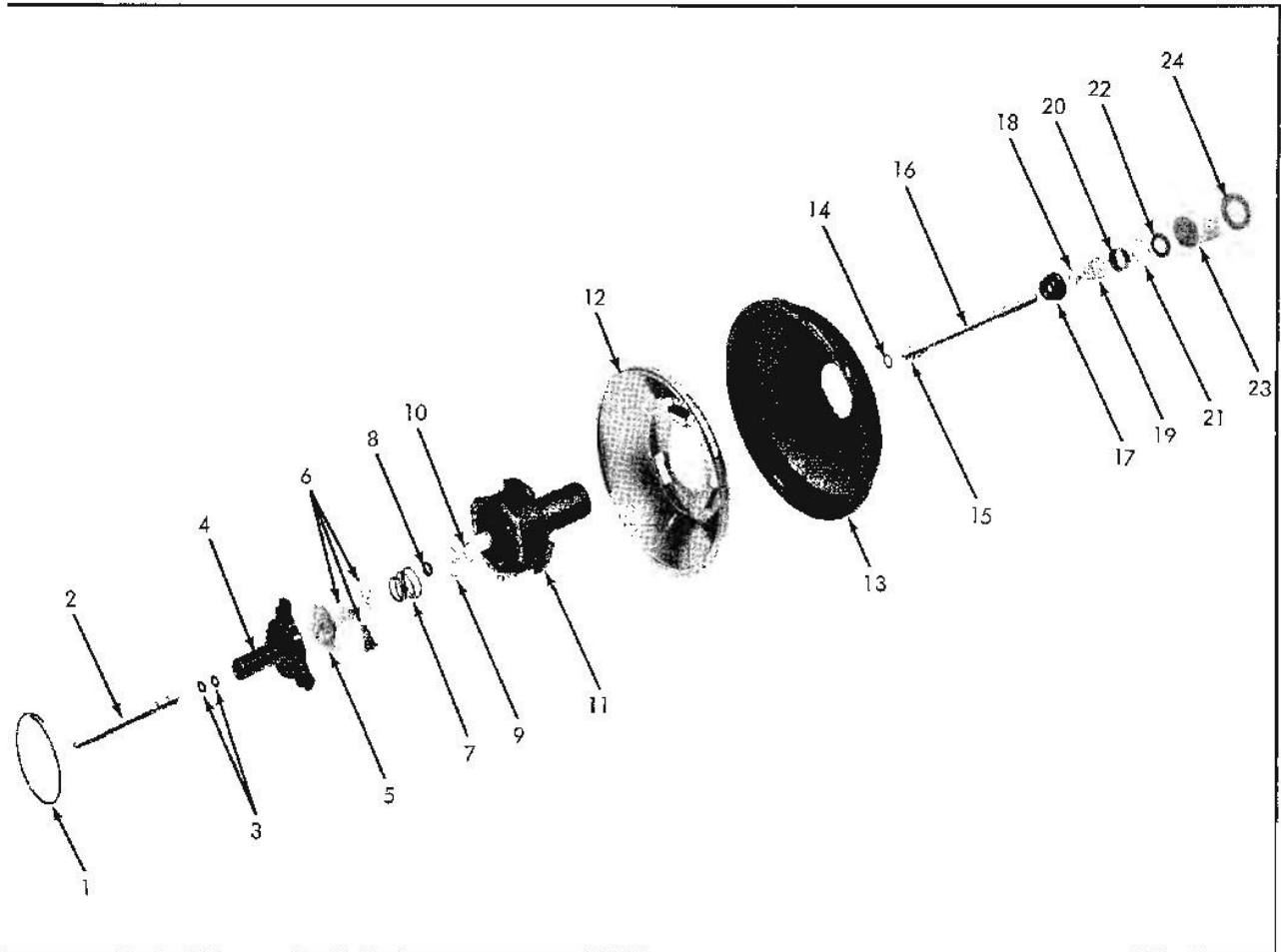

Fig. 5A-9 Power Piston - Exploded View

- |                              |                               |                                    |
|------------------------------|-------------------------------|------------------------------------|
| 1. Lock Ring                 | 9. Retainer, Air Valve Spring | 17. Floating Control Valve         |
| 2. Hydraulic Piston Push Rod | 10. Retaining Ring            | 18. Spring Seat                    |
| 3. "O" Ring Seal             | 11. Power Piston              | 19. Control Valve Spring           |
| 4. Reaction Retainer         | 12. Support Plate             | 20. Floating Valve Spring Retainer |
| 5. Reaction Plate            | 13. Diaphragm                 | 21. Floating Valve Retainer        |
| 6. Reaction Levers           | 14. "O" Ring                  | 22. Push Rod Limiter Washer        |
| 7. Air Valve Spring          | 15. Air Valve                 | 23. Filter                         |
| 8. Reaction Bumper           | 16. Valve Operating Rod       | 24. Silencer                       |

**MASTER CYLINDER ASSEMBLY**

Inspect bore from the open end. The bore should be free from scores, deep scratches and corrosion. If it appears that corrosive brake fluid has damaged the bore, replace damaged parts and flush out entire brake system including wheel cylinders.

The sealing surfaces should be clean and smooth. Check for cracks and damaged threads. Be sure that the by-pass and compensating ports to the master cylinder are not restricted.

Check for distortion of all springs and deterioration of all rubber parts. Any evidence of soft or

swollen rubber parts indicates contaminated brake fluid requiring flushing of the entire brake system and replacement of wheel cylinder cups, as well as all rubber parts in master cylinder.

**AIR FILTER**

Replace air filter element if dirty.

**BRAKE ASSEMBLY—ASSEMBLE**

**MASTER CYLINDER—ASSEMBLE**

1. Install new reservoir diaphragm in reservoir cover, place cover in position and snap on wire bail.

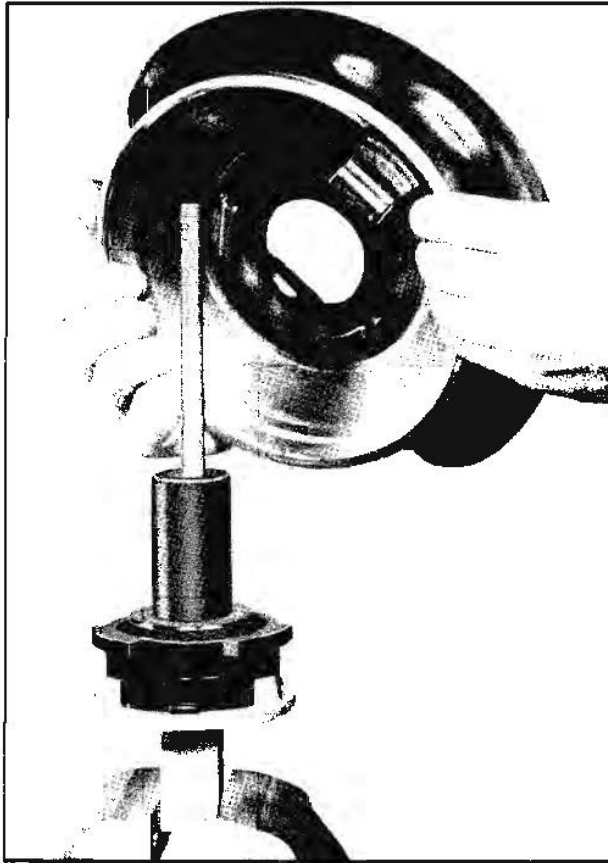

Fig. 5A-10 Removing Support Plate

2. Place master cylinder in vise with open end of bore accessible and position check valve washer in bottom of bore so that it lies flat.

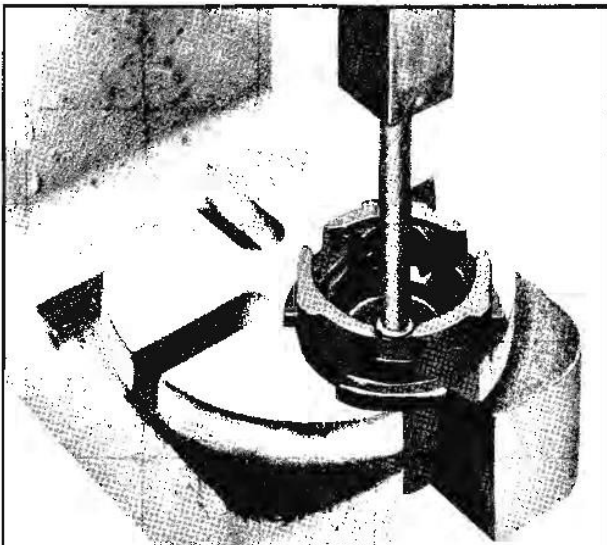

Fig. 5A-11 Removing Air Valve

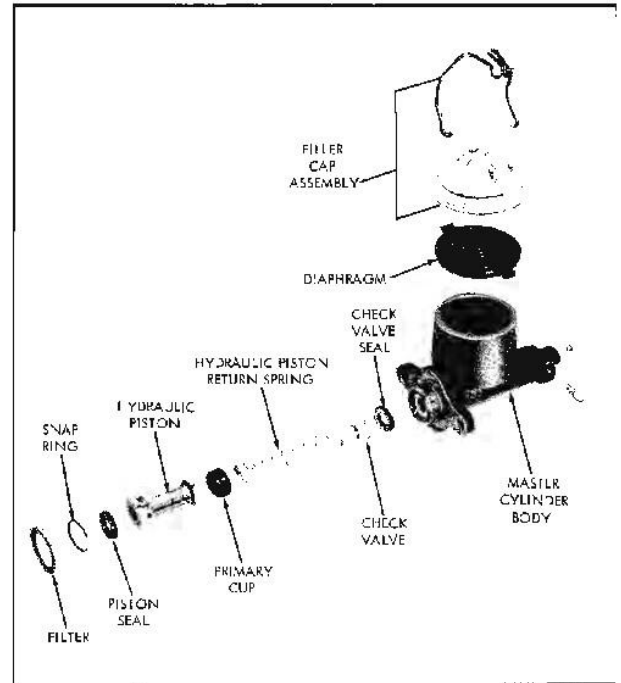

Fig. 5A-12 Master Cylinder - Exploded View

3. Press check valve in open end of spring retainer and position in bore against valve seat washer.

4. Dip primary cup in clean brake fluid and position in bore with lips over spring and retainer assembly.

5. Assemble secondary seal in groove on master cylinder piston so that lip faces toward end of piston which contains small by-pass holes.

6. Press master cylinder piston into bore so that flat end of piston, which contains by-pass holes lies against flat surface of piston cup.

7. Install snap ring in groove of cylinder.

8. Place a new filter in groove on open end of master cylinder.

9. Position master cylinder on front housing studs and tighten nuts finger tight.

#### POWER PISTON—ASSEMBLE

1. Place two new O-rings in grooves on master cylinder piston rod. Wipe thin coat of power brake lubricant on O-rings.

2. Insert piston rod through reaction retainer so that round end of rod protrudes from end of tube on reaction retainer.

3. Place power piston wrench, J-21524 in vise and position power piston on wrench with three lugs fitting into notches in piston.

4. Install new O-ring on air valve in second groove from push rod end.

*NOTE: A new floating control valve must be installed since force required to remove distorts component parts.*

5. Place floating control valve on push rod - air valve assembly, so that flat face of valve will seat against valve seat on air valve.

6. Wipe thin film of power brake lube on large O.D. of floating control valve and on O-ring of air valve.

7. Press air valve - push rod assembly, air valve first, to its seat in tube of power piston.

8. Place floating valve retainer over push rod so that flat side seats on floating control valve.

9. Start floating valve and its retainer into power piston tube. A five inch long piece of 1-1/8" O.D. tubing can be used to press floating valve to seat in tube by placing tubing on top of retainer and pressing down.

10. Position push rod limiter washer over push rod to floating control valve and install two air filter elements over end of push rod and into power piston tube.

11. Assemble power piston diaphragm to support plate from side of plate opposite locking tangs and press raised flange of diaphragm through hole in center of plate.

*NOTE: Be sure that edge of center hole fits into groove in flange of diaphragm.*

12. Pull diaphragm away from O.D. of support plate so that it can be gripped with hands and wipe power brake lubricant on all surfaces of small bead of diaphragm which contacts power piston.

13. Holding support plate on bare metal, with locking tangs down, place support plate and diaphragm assembly down over tube of power piston. Flange of diaphragm will fit into groove on power piston.

14. Press down and rotate support plate clockwise until lugs on power piston come against stops on support plate.

15. Invert assembly and place in padded vise with tube end down and insert snap ring on air valve using Truarc Pliers.

16. Place air valve spring retainer to seat on snap ring and assemble reaction bumper into groove in end of air valve.

17. Position air valve return spring, large end down, on spring retainer.

18. Position three reaction levers in slots on power piston. Narrow ends will rest on top of air valve return spring.

19. Position reaction plate, with numbered side up, on top of reaction levers and press down on plate until large ends of reaction levers pop up so that plate rests flat on levers. Be sure that reaction plate is centered.

20. Place small end of piston rod in hole in center of reaction plate and line up ears on reaction retainer with notches in power piston and push reaction retainer down until ears seat in notches.

21. Maintain pressure on reaction retainer and position large lock ring down over master cylinder push rod so that one end of lock ring goes under lug on power piston raised divider.

*NOTE: Lock ring is positioned around power piston so that it goes alternately over ear of reaction retainer and under lug on power piston until end of ring is seated under lug with raised divider.*

*CAUTION: Make sure that both ends of lock ring are securely under large lug.*

22. Place new front housing seal in center of front housing so that flat surface of cup lies against bottom of depression in housing.

23. Replace vacuum check valve using new grommet if old one is cracked or damaged.

24. Place new power piston bearing in center of rear housing so that flange on center hole of housing fits into groove of power piston bearing. Large flange on power piston bearing will be on stud side of housing.

25. Coat inside of power piston bearing with power brake lube.

26. Place air silencer over holes on tube of power piston and wipe tube with power brake lube.

27. Assemble power piston to rear housing by pushing tube of power piston through rear housing from side opposite studs.

28. Wipe tube of reaction retainer with power brake lube and lay assembly aside.

29. Place front housing in vise with master cylinder down. Position power piston return spring over inset in front housing. Lubricate I.D. of support plate seal with power brake lube.

30. Lubricate beaded edge of diaphragm lightly with talcum powder. Hold rear housing and power piston assembly over front housing with master cylinder push rod down and position rear housing so that scribe marks on housings will be in line when it is rotated into locked position.

31. Place rod in position on rear housing. Press down to check that bead of diaphragm is positioned between edges of housings. If this is satisfactory, apply additional pressure on rear housing and, at the same time rotate housing clockwise into locked position. If housings are not easily locked, hold housing together and apply vacuum to check valve in front housing. This will draw housings together and will ease locking procedure.

*CAUTION: Do not put pressure on power piston tube when locking housings and be careful not to break studs in rear housing.*

32. Push felt silencer over push rod to seat against end of power piston tube and place snap ring retainer on push rod to hold silencer against power piston tube.

33. Seat plastic boot against rear housing. Raised humps on side of boot will locate in large holes in center of brackets. Install jam nut and clevis on push rod.

## PUSH ROD ADJUSTMENT

1. Place power brake assembly in vise so that master cylinder is up. Remove master cylinder from front housing. Master cylinder push rod is now exposed.

2. Place gauge J-7723 over piston rod so that it fits between the two studs on front housing (Fig. 5A-13). It should be parallel to studs and resting on surface of housing. Cutout portion of gauge should never be lower than end of piston rod, and gap between cutout in gauge and end of piston rod should never be more than 0.010 inch.

*NOTE: Any variation beyond these two limits must be compensated for by obtaining service adjustable piston rod and adjusting screw in end to match height of gauge.*

3. Replace master cylinder on front housing studs. Install lockwashers and nuts on studs. Torque to 15-20 lb. ft.

*CAUTION: After replacing unit on vehicle start engine and allow vacuum to build up before applying brakes.*

## POWER BRAKE ASSEMBLY—INSTALL

1. Place power brake into position and install four rear housing to dash attaching lockwashers and nuts from inside of car. Tighten nuts 20-35 lb. ft. torque.

2. Attach clevis to brake pedal assembly and adjust pedal to height to provide 3-1/8" to 3-3/8" clearance from floor mat to bottom of pedal pad. Secure clevis lock nut and tighten 5-10 lb. ft. torque.

3. See page 5A-6 for stoplight switch adjustment.

4. Attach vacuum line.

5. Attach hydraulic line.

6. Bleed brakes as necessary and fill fluid reservoir to provide a distance of 1/2" from top of filler hole.

## SYSTEM TESTS

Road test the brakes by making a brake application at about 20 MPH to determine if the vehicle stops

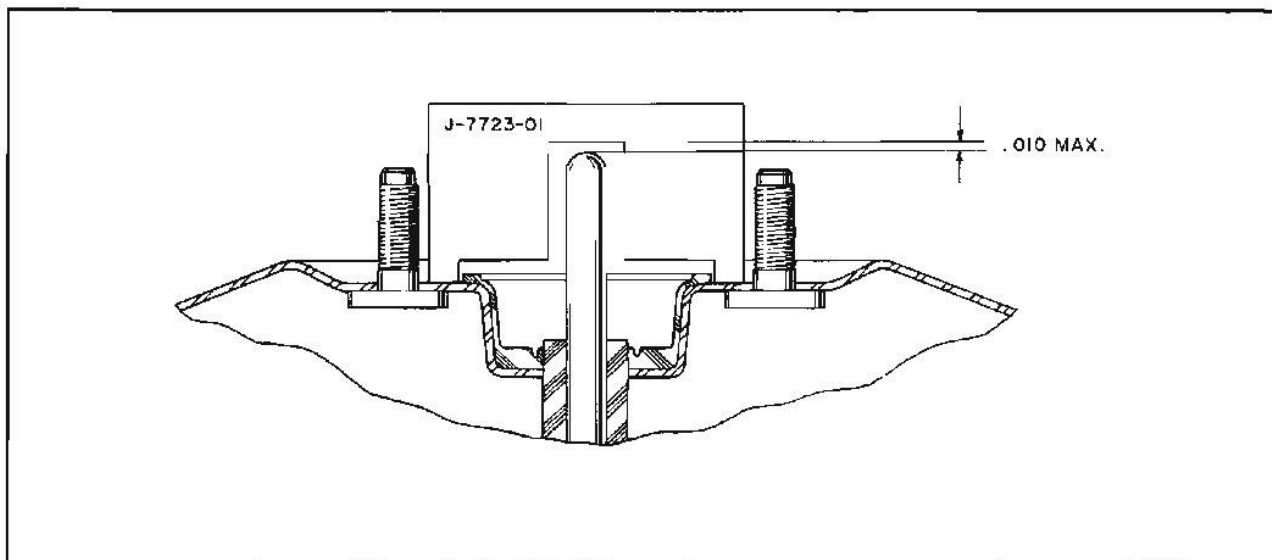

Fig. 5A-13 Checking Master Cylinder Push Rod Adjustment

evenly and quickly. If the pedal has a spongy feel when applying the brakes, air may be present in the hydraulic system and bleeding of brakes may be required.

When the engine is stopped and the transmission is in neutral, apply brakes several times to deplete all vacuum reserve in the system. Depress brake pedal, hold light-foot pressure on the pedal, and start the engine. If the vacuum system is operating, the pedal will tend to fall away under foot pressure, and less pressure will be required to hold pedal in applied position. If no action is felt, the vacuum system is not functioning.

Stop engine and deplete all vacuum reserve in the system. Depress the brake pedal and hold foot pressure on the pedal. If the pedal gradually falls away under foot pressure, the hydraulic system is leaking.

If the brake pedal travels to within one inch of the toe-board, the brake shoes require adjustment or relining.

Start engine with brakes off, run to medium speed and turn off the ignition. Immediately close the throttle to build up vacuum. Wait at least 90 seconds, then try brake action. If not vacuum-assisted for two or more applications, vacuum check valve is faulty or leak exists in vacuum system.

## TROUBLE DIAGNOSIS

The same types of brake trouble are encountered with power brakes as with standard brakes. Before checking the power brake system for the source of trouble, refer to the trouble diagnosis of standard brakes in the shop manual. After these possible causes have been eliminated, check for the cause as outlined below:

### HARD PEDAL

#### (a) Vacuum failure due to:

1. Faulty vacuum check valve.
2. Collapsed vacuum hose to manifold.
3. Plugged or loose vacuum fittings.

#### (b) Tight pedal linkage

#### (c) Power brake unit trouble

1. Jammed air valve.
2. Vacuum leaks in unit caused by: faulty air valve seal or support plate seal. Also, a damaged, floating control valve, faulty seal of master cylinder, or power cylinder mounting studs in housings, faulty seal on master cylinder push rod or a faulty seal of the diaphragm bead between the

housings, or at power piston. It is also possible to have faulty vacuum check valve grommet.

3. Defective rolling diaphragm.
4. Restricted air filter elements.
5. Worn or badly-distorted reaction plate or levers.
6. Cracked or broken power piston or reaction retainer.

#### GRABBY BRAKES (APPARENT OFF-AND-ON CONDITION)

- (a) Power brake unit valve trouble.
  1. Sticking air valve.
  2. Restricted diaphragm passage.
- (b) Reaction system.
  1. Dislodged reaction levers.
  2. Broken air valve spring.
  3. Worn or distorted levers or plates.

#### PEDAL GOES TO THE FLOOR OR ALMOST TO THE FLOOR

- (a) Fluid reservoir needs replenishing.
- (b) Power brake hydraulic system leakage.
  1. Defective primary or secondary cups.
  2. Cracked master cylinder casting.
  3. Leaks at wheel cylinder, in pipes, at hoses or connections.
- (c) Faulty master cylinder check valve has permitted air to enter system, causing spongy pedal.

#### BRAKES FAIL TO RELEASE

- (a) Faulty hydraulic check valve.
- (b) Blocked passage in power piston.
- (c) Air valve sticking.
- (d) Broken piston return spring.
- (e) Broken air valve spring.
- (f) Tight pedal linkage.

#### TORQUE SPECIFICATIONS

	Lb. - Ft.
Power Cylinder Housing-to-Master Cylinder Nuts . . . . .	15-20
Rear Housing to Dash Nuts . . . . .	15-25
Clevis Lock Nut . . . . .	5-10

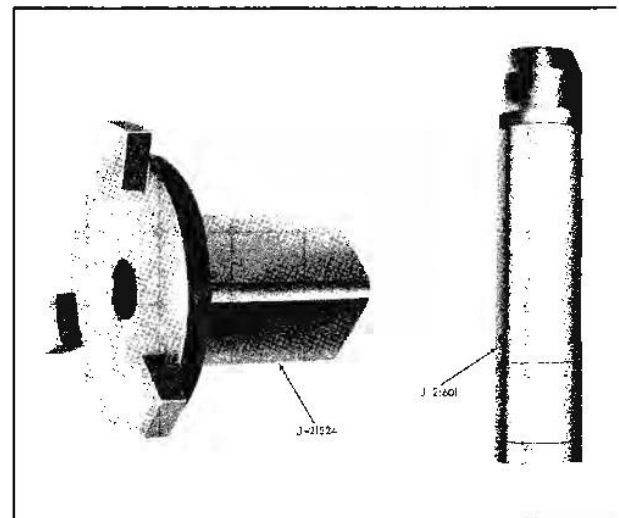

Fig. 5A-14 Special Tools