

# STANDARD TRANSMISSION AND GEARSHIFT CONTROL

## CONTENTS OF THIS SECTION

SUBJECT	PAGE	SUBJECT	PAGE
Description . . . . .	7-1	Cleaning and Inspection	
Design . . . . .	7-1	Transmission Case and Extension . . .	7-17
Operation . . . . .	7-3	Ball Bearings . . . . .	7-17
Periodic Service . . . . .	7-5	Gears . . . . .	7-17
Adjustments on Car		Reverse Idler Gear Shaft Bushings, Thrust Washers and Bearing: and Needle Roller Bearings . . . . .	7-17
Gearshift Rod Adjustment (column) . . . .	7-6	Clutch (Sleeve), Synchronizer	
Gearshift Rod Adjustment (floor) . . . .	7-6	Rings and Cones . . . . .	7-18
Minor Repairs		Internal Components - Assemble	
Shift Linkage and Steering Column . . . .	7-9	Transmission Case Extension Bearing and Oil Seal - Replace . . . . .	7-18
Speedometer Driven Gear -		Synchronizer Energizing - Replace . . .	7-18
Remove . . . . .	7-9	Clutch (Sleeve) and Synchronizer	
Install . . . . .	7-10	Rings - Assemble . . . . .	7-18
Transmission Extension Oil Seal -		Main Drive (Clutch) Gear - Assemble .	7-18
Remove . . . . .	7-11	Mainshaft - Assemble . . . . .	7-19
Install . . . . .	7-11	Transmission - Assemble	
Transmission Side Cover -		Reverse Idler Gear . . . . .	7-19
Remove and Disassemble . . . . .	7-11	Countergear and Main Drive (Clutch) Gear . . . . .	7-20
Assemble and Install . . . . .	7-12	Synchronizing Clutch Sleeve -	
Major Repairs		First and Reverse Sliding Gear . . .	7-21
Transmission - Remove and Overhaul . .	7-12	Mainshaft and Extension . . . . .	7-21
Transmission - Disassemble . . . . .	7-14	Transmission - Install in Vehicle . . . .	7-22
Mainshaft - Disassemble . . . . .	7-15	Trouble Diagnosis and Testing . . . . .	7-23
Main Drive (Clutch) Gear -		Transmission	
Disassemble . . . . .	7-15	Specifications . . . . .	7-25
Clutch (Sleeve) and Synchronizer		Torque Specifications . . . . .	7-25
Rings - Disassemble . . . . .	7-16	Special Tools . . . . .	7-26
Synchronizer Energizing Springs -			
Remove . . . . .	7-16		
Transmission Case Extension Oil Seal and Bushing - Remove . . . . .	7-16		

## DESCRIPTION

The three-speed synchromesh transmission is used as standard equipment on all 6 and 8 cylinder Tempest models.

It consists of two basic sections; the transmission case, or forward section, and the case extension, or rear section. The forward section contains the main gear assemblies, clutch assembly and synchronizing mechanism, while the rear section acts as a supporting member for the entire unit.

Gearshifting is manual through a concentric steering column gearshift mechanism (Fig. 7-8 & 7-9) which activates two rods connected to the shifter

levers at the transmission case side cover. A floor mounted shift control lever, with or without a console, is available as optional equipment, (Fig. 7-10 & 7-11). Shifting of gears is accomplished by the movement of two shift forks which directly engage the gears to be shifted.

## DESIGN

The transmission incorporates all helical gears which are machined from drop-forged steel gear blanks, heat-treated and shot peened for strength and long life. The shafts are machined from high grade steel, heat-treated and ground to close limits.

The transmission assembly consists of five basic gears of varying size and design. These gears are

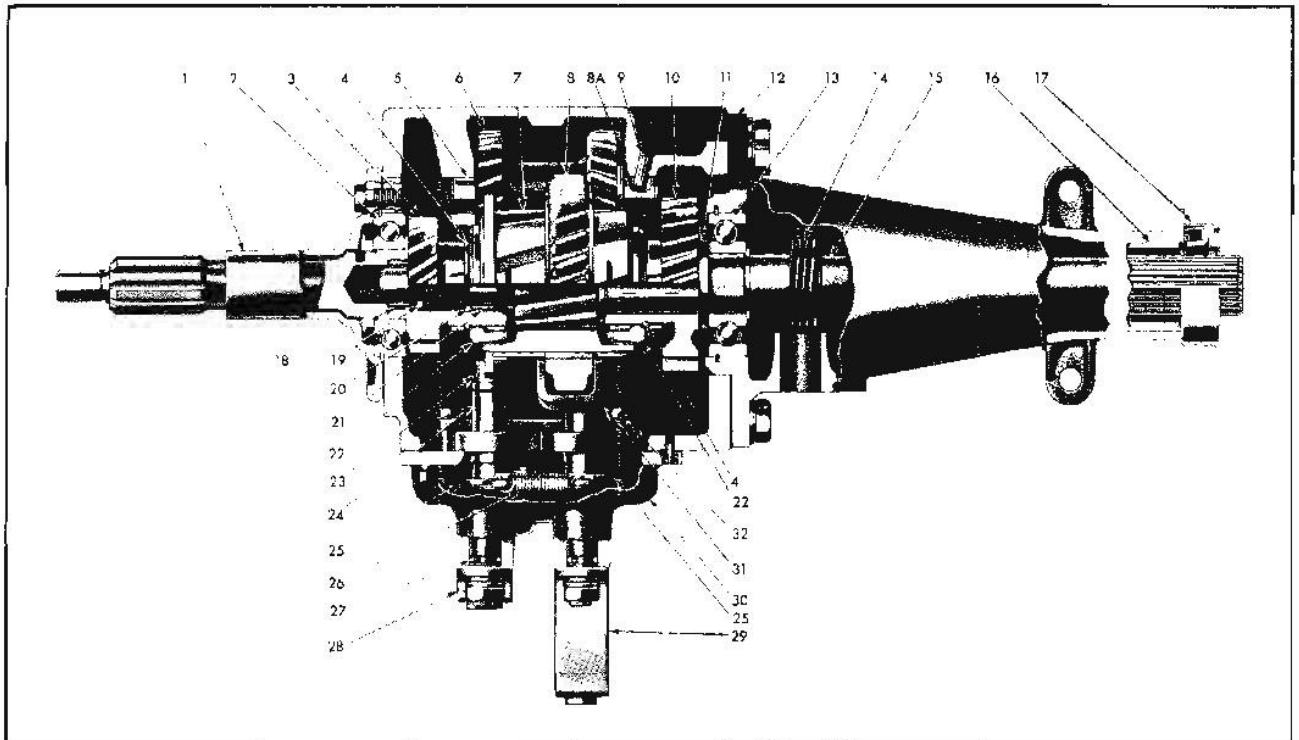

- |                                   |                                 |                                     |
|-----------------------------------|---------------------------------|-------------------------------------|
| 1. Clutch Gear Bearing Retainer   | 11. Thrust Washer               | 22. Synchronizer Ring               |
| 2. Clutch Gear Bearing            | 12. Case Extension              | 23. Second and Third Shifter Fork   |
| 3. Clutch Gear                    | 13. Mainshaft Rear Bearing      | 24. Second and Third Shifter Shaft  |
| 4. Energizing Spring              | 14. Speedometer Drive Gear      | 25. Detent Cam                      |
| 5. Reverse Idler Shaft            | 15. Mainshaft                   | 26. Detent Cam Spring               |
| 6. Reverse Idler Gear             | 16. Bushing                     | 27. "O" Ring Oil Seal               |
| 7. Second and Third Speed Clutch  | 17. Oil Seal                    | 28. Second and Third Shifter Lever  |
| 8. First and Reverse Sliding Gear | 18. Front Pilot Bearing Rollers | 29. First and Reverse Shifter Lever |
| 8a. Thrust Bearing and Washer     | 19. Thrust Washer               | 30. Side Cover                      |
| 9. Reverse Idler Shaft Pin        | 20. Thrust Washer               | 31. First and Reverse Shifter Fork  |
| 10. Second Speed Gear             | 21. Rear Pilot Bearing Rollers  | 32. Interlock Retainer              |

Fig. 7-1 Cross Section of Three-Speed Synchronemesh Transmission - Top View

so positioned that, when one gear is brought into mesh with another, proper ratios are attained for first, second, third and reverse speeds.

Six cylinder models incorporate gear ratios of 2.94 in first, 1.68 in second and 1.00 in high. Reverse ratio is 2.94:1. Tempests equipped with a V-8 engine use a transmission similar to the one for the six cylinder model, except for gears of coarser teeth for added strength to accept the higher torque output. Gear ratios for this transmission are 2.58 in first, 1.48 in second, 1.00 in high and 2.58 in reverse.

A synchronizing mechanism, consisting of two cone-type synchronizing rings, is incorporated in the second and third speed clutch. It is this mechanism which allows the gears to be meshed properly while in motion.

The rear end of the main drive (clutch) gear is supported by a heavy duty ball bearing at the front end of the transmission case (Fig. 7-1) and is piloted at its front end in an oil impregnated bushing (ball bearing in V-8 engines) mounted in the engine crankshaft.

The front end of the mainshaft is piloted in a double row of needle bearing rollers set into the hollow end of the main drive (clutch) gear and the rear end of the mainshaft is carried by a heavy duty ball bearing located in the face of the rear extension (Fig. 7-1).

The countergear is carried on needle bearing rollers positioned at both ends of the countershaft and thrust is taken on bronze thrust washers located between each end of the gear and the case. Roller

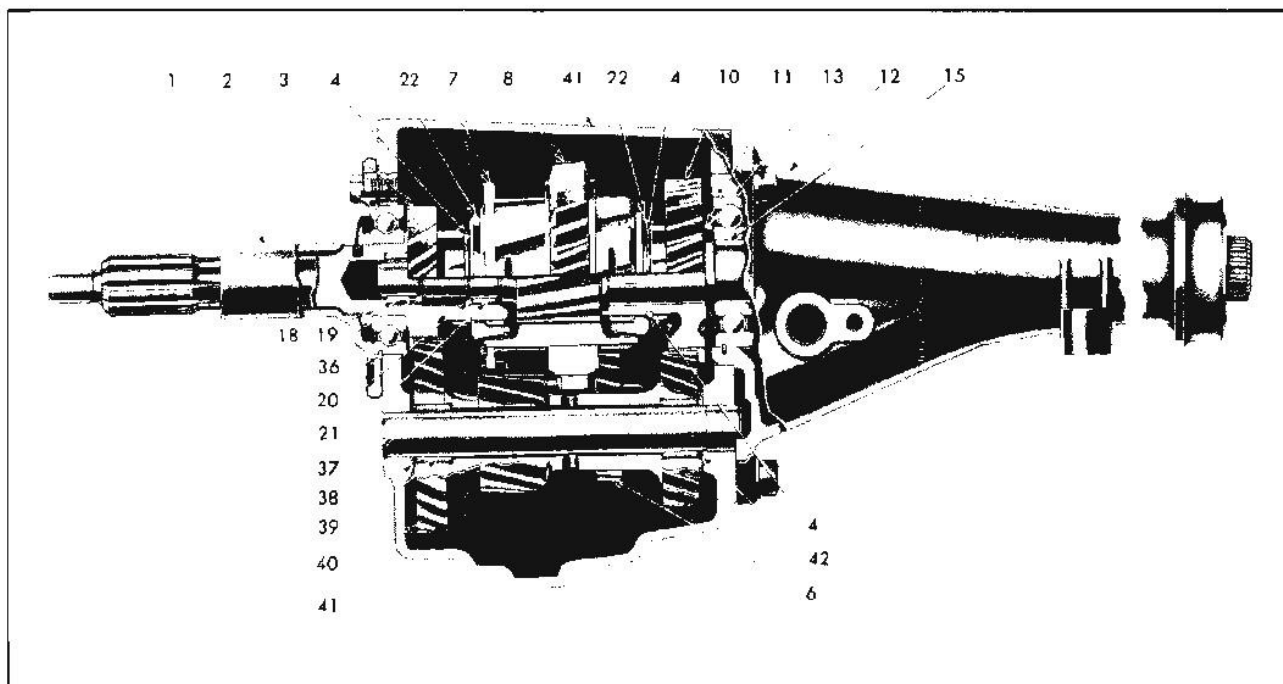

- |                                   |                                 |                                   |
|-----------------------------------|---------------------------------|-----------------------------------|
| 1. Clutch Gear Bearing Retainer   | 12. Case Extension              | 34. Lock Plate                    |
| 2. Clutch Gear Bearing            | 13. Mainshaft Rear Bearing      | 35. Speedometer Driven Gear Shaft |
| 3. Clutch Gear                    | 15. Mainshaft                   | 36. Snap Ring                     |
| 4. Energizing Spring              | 18. Front Pilot Bearing Rollers | 37. Countershaft                  |
| 6. Reverse Idler Gear             | 19. Thrust Washer               | 38. Thrust Washer                 |
| 7. Second and Third Speed Clutch  | 20. Thrust Washer               | 39. Roller Bearing                |
| 8. First and Reverse Sliding Gear | 21. Rear Pilot Bearing Rollers  | 40. Countergear                   |
| 10. Second Speed Gear             | 22. Synchronizer Ring           | 41. Transmission Case             |
| 11. Thrust Washer                 | 33. Speedometer Shaft Fitting   | 42. Roller Thrust Washer          |

Fig. 7-2 Cross Section of Three-Speed Synchromesh Transmission - Side View

bearing thrust washers are installed between the thrust washers and the roller bearings (Fig. 7-2).

The reverse idler gear is carried on ball-indented bronze bushings pressed into front and rear ends of the gear. Forward thrust of the gear is taken on a washer located between the front of the gear and the case, and rearward thrust is taken on a radial roller thrust bearing and washer positioned between gear and case (Fig. 7-1).

The second speed gear floats on the mainshaft, while the first and reverse sliding gear is positioned so that it rides on the second and third speed clutch assembly (Figs. 7-1 and 7-2).

### OPERATION

The main drive (clutch) gear is in constant mesh with the countergear, which in turn is in constant mesh with the reverse idler gear and second speed gear. Therefore, with the engine running and the

engine clutch engaged, torque is imparted to the main drive (clutch) gear, countergear, second speed gear, and reverse gear at all times.

#### OPERATION IN NEUTRAL (Fig. 7-3)

In neutral, the first and reverse sliding gear is positioned so that it does not mesh with the countergear or the reverse idler gear. The second and third speed clutch is positioned so that it does not engage the second speed gear or the main drive clutch gear. Therefore, with engine clutch engaged, the main drive (clutch) gear, countergear, second speed gear, and reverse idler gear are turning, but no power is being transmitted through the mainshaft.

#### OPERATION IN FIRST (Fig. 7-4)

In first speed, the first and reverse sliding gear is moved forward to engage the countergear, which is being turned by the main drive (clutch) gear. This engagement activates the first and reverse sliding

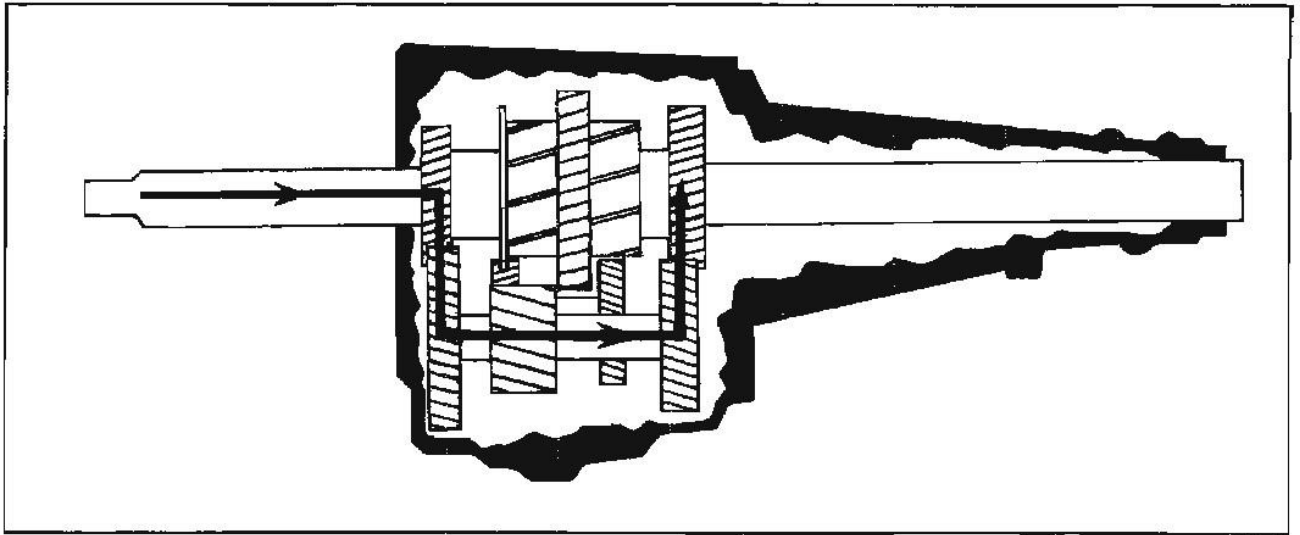

Fig. 7-3 Three-Speed Synchromesh - Power Flow in Neutral

gear which rides on, and is splined to the second and third speed clutch (sleeve). Because the second and third speed clutch is splined to the mainshaft, torque applied to the clutch through the first and reverse sliding gear is imparted directly to the mainshaft.

#### OPERATION IN SECOND (Fig. 7-5)

In second speed, the first and reverse sliding gear is moved to a neutral position. The second and third speed clutch, which is splined to the mainshaft, is moved toward the rear of the transmission to engage the second speed gear, which floats on the mainshaft.

Since the main drive (clutch) gear and second speed gear are always in mesh with the countergear, and since the second and third speed clutch is splined to the mainshaft, engaging the second and third speed clutch with the second speed gear will cause the mainshaft to turn.

#### OPERATION IN THIRD (Fig. 7-6)

In third speed, or direct drive, the second and third speed clutch is disengaged from the second speed gear and moved forward until it engages the main drive (clutch) gear. Since the second and third speed clutch is splined to the mainshaft, torque is

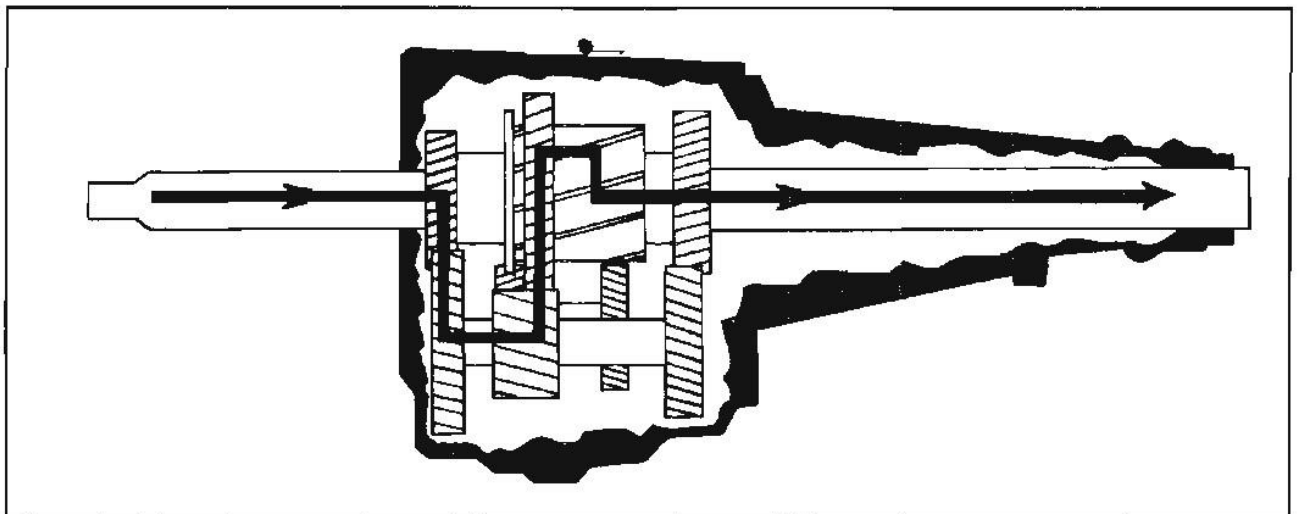

Fig. 7-4 Three-Speed Synchromesh - Power Flow in First Speed

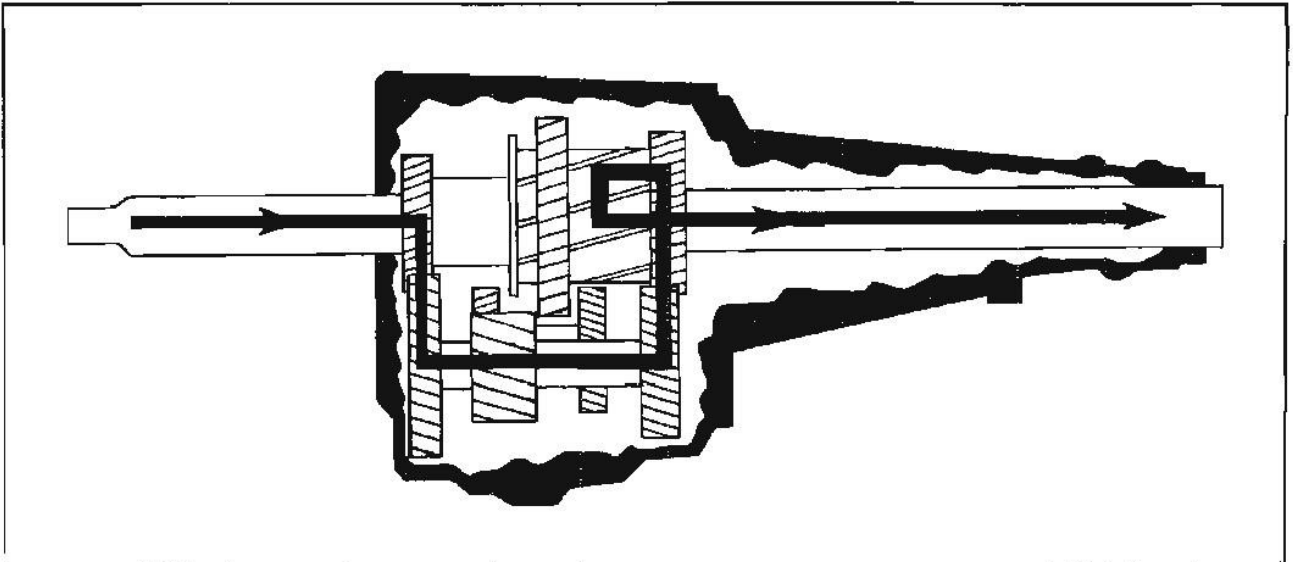

Fig. 7-5 Three-Speed Synchromesh - Power Flow in Second Speed

applied directly to the mainshaft in the direction of engine rotation at engine speed.

#### OPERATION IN REVERSE (Fig. 7-7)

In reverse speed, the second and third speed clutch assumes a neutral position and the first and reverse sliding gear is moved rearward to engage the reverse idler gear. Since the first and reverse sliding gear rides on, and is splined to, the second and third speed clutch (sleeve), which is splined to the mainshaft, the power flow is directed through the main drive (clutch) gear, countergear, reverse idler gear,

and first and reverse sliding gear to the mainshaft. As power flows from reverse idler gear to first and reverse sliding gear, the direction of rotation is reversed, making it opposite that of the engine.

### PERIODIC SERVICE

#### TRANSMISSION

No periodic service of the transmission is required except checking for leaks and proper lubricant level every 6000 miles.

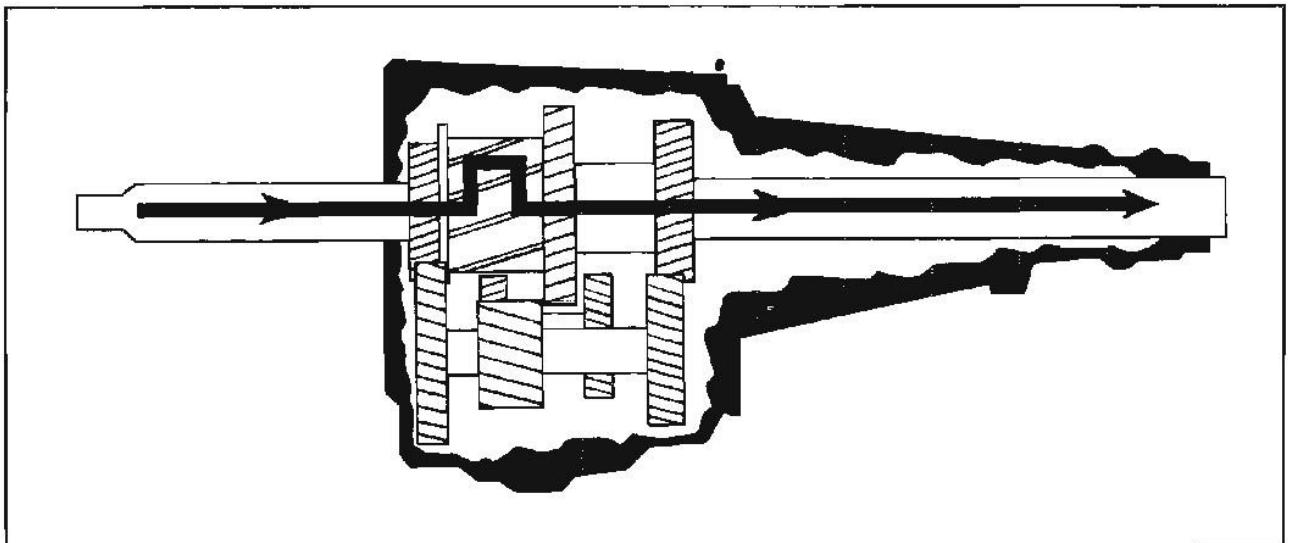

Fig. 7-6 Three-Speed Synchromesh - Power Flow in Third Speed

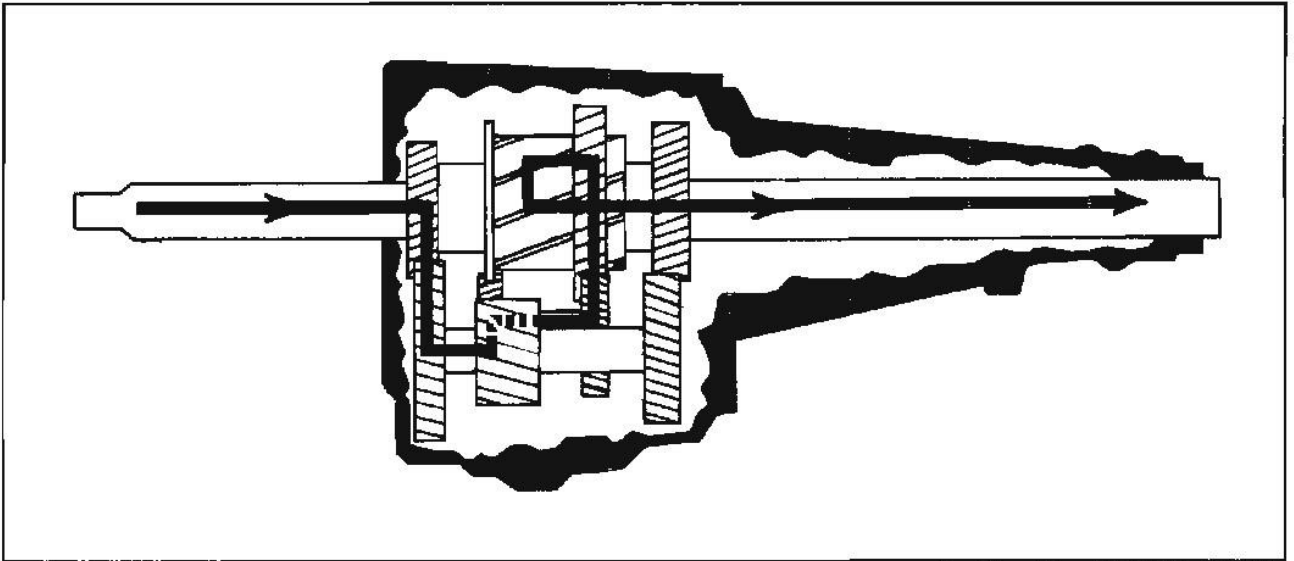

Fig. 7-7 Three-Speed Synchromesh - Power Flow in Reverse

If there is evidence of leakage, the leak should be corrected and lubricant added, if needed. Refill capacity is 1.8 pints.

Use SAE 90 "Multi-purpose Gear Lubricant". No special additive to this lubricant is required or recommended.

#### SHIFT CONTROL

No periodic service of the shift control is required. Certain parts are lubricated on assembly and require further lubrication only when parts become dry and sticky.

### ADJUSTMENTS ON CAR

#### GEARSHIFT LINKAGE ADJUSTMENT (Column) (Fig. 7-8 & 7-9)

*NOTE: In cases where the linkage has been disconnected, lubricate linkage joints with chassis grease, assemble shift rods to column levers and transmission levers and tighten swivel nuts finger tight.*

1. Position selector lever at upper end of column in neutral.
2. Retain levers at lower end of steering column in neutral.

3. Loosen 2 swivel nut assemblies.
4. Position both levers on transmission in neutral.
5. Tighten swivel nuts to 8-12 lb. ft. torque.
6. Check complete shift pattern with engine off. Start engine and repeat complete shift pattern.

*NOTE: If adjustments are made as outlined above and clutch lash is correct (see Section 6D) shifting should be smooth in and out of any gear with proper movement of selector lever by the operator.*

#### GEARSHIFT LINKAGE ADJUSTMENT (Floor) (Fig. 7-10)

*NOTE: In cases where the linkage has been disconnected, lubricate linkage joints with chassis grease, assemble shift rods to transmission levers and bracket assembly control levers and tighten swivel nuts finger tight.*

1. Position selector lever in neutral position.
2. Loosen two swivel nut assemblies.
3. Insert 1/4 diameter gauge pin into bracket and lever assembly control levers and align them in neutral position.
4. Position levers on transmission in neutral position.







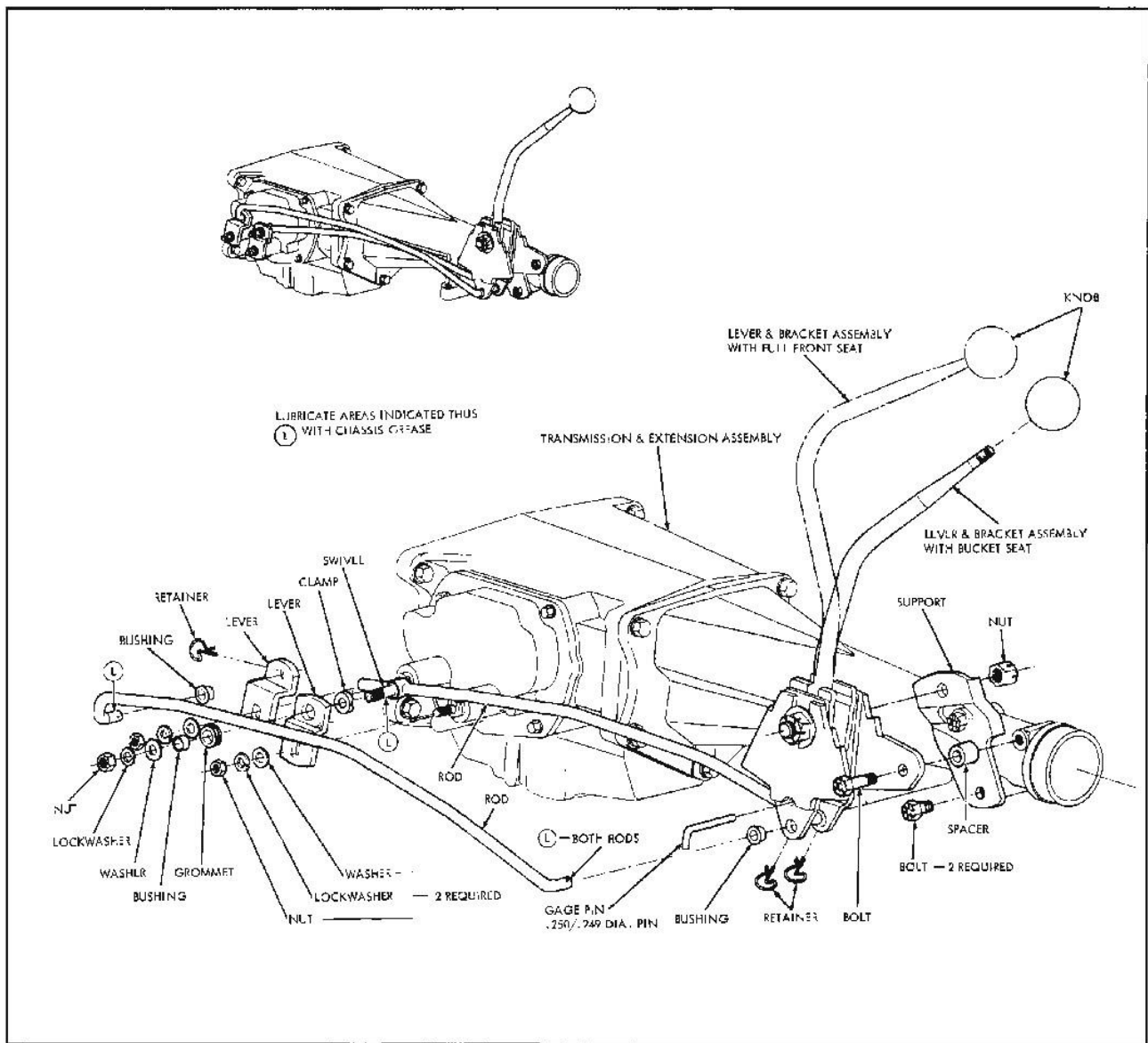

Fig. 7-10 Gearshift Controls (Floor)

5. Tighten swivel nut assemblies to 8-12 lb. ft. torque.

6. Remove gauge pin.

7. Check complete shift pattern with engine off. Start engine and repeat complete shift pattern.

*NOTE: If shift rod adjustments are made as outlined above and clutch lash is correct (see Section 6D) shifting should be smooth in and out of any gear, with proper movement of selector lever by operator.*

## MINOR REPAIRS

### SHIFT LINKAGE AND STEERING COLUMN

If shift rods or second and third shift lever rod assembly are to be replaced, disconnect them as required. Remove and overhaul of the steering column is covered in section 9.

### SPEEDOMETER DRIVEN GEAR—REMOVE

1. Disconnect speedometer cable.

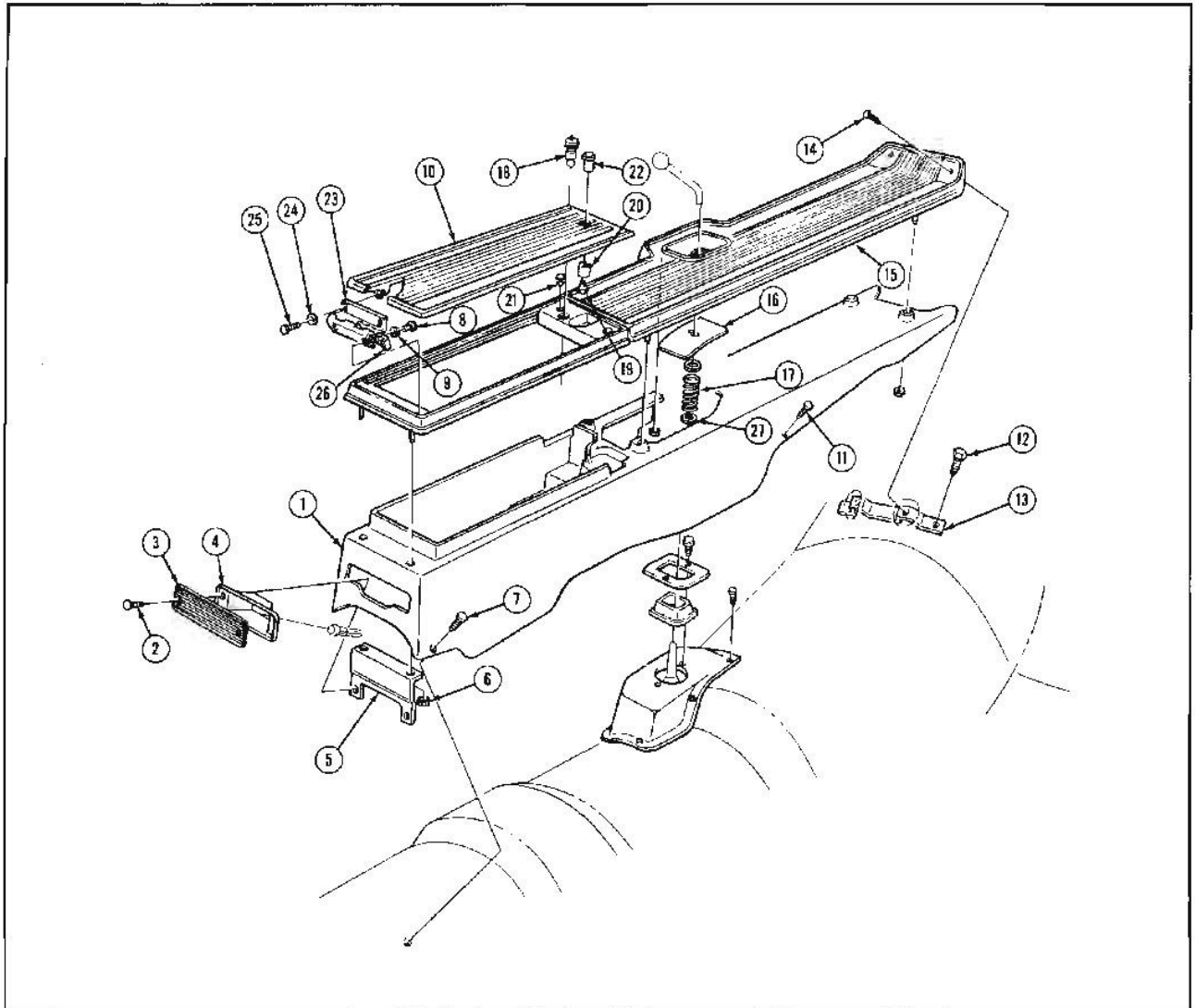

- |                         |                          |                         |                 |
|-------------------------|--------------------------|-------------------------|-----------------|
| 1. Console              | 8. Screw                 | 15. Moulding Assy.      | 22. Lock Assy.  |
| 2. Screw                | 9. Washer                | 16. Cover               | 23. Hinge Assy. |
| 3. Lens                 | 10. Door                 | 17. Spring              | 24. Washer      |
| 4. Lamp Assy.           | 11. Screw & Sealer Assy. | 18. Switch & Lamp Assy. | 25. Screw       |
| 5. Retainer             | 12. Screw & Sealer Assy. | 19. Screw               | 26. Spring      |
| 6. Nut                  | 13. Bracket              | 20. Retainer            | 27. Washer      |
| 7. Screw & Sealer Assy. | 14. Screw                | 21. Bumper              |                 |

Fig. 7-11 Exploded View - Console

2. Remove retainer to extension bolt and lock washer and remove retainer.

3. Insert screwdriver in lock plate slot in fitting and pry fitting, gear and shaft from extension.

4. Pry "O" ring from groove in fitting.

5. Check gear, shaft and fitting for wear and replace if necessary.

*NOTE:* Check for correct usage by referring to speedometer drive and driven gear usage chart in Section 1.

#### SPEEDOMETER DRIVEN GEAR—REPLACE

1. Install new "O" ring in groove of speedometer gear and sleeve assembly.

2. Hold the assembly so slot is toward boss on extension and insert assembly into extension,

3. Push assembly into extension until retainer can be inserted in groove.

4. Install retainer to extension bolt and lock washer and tighten 35-60 lb. in.

5. Connect speedometer cable to speedometer driven gear and sleeve assembly.

#### TRANSMISSION EXTENSION OIL SEAL—REMOVE

To inspect or replace the rear extension oil seal, it is necessary to remove the propeller shaft drive line assembly from the vehicle.

1. Remove U-bolt nuts, lock plates and U-bolts from rear axle drive pinion flange.

2. Use suitable rubber band to hold bearings onto journals, if tie wire has been removed, to prevent loss of needle bearings when rear joint is disconnected.

3. Slide propeller shaft assembly rearward to disengage yoke from splines on transmission mainshaft and remove.

4. Using punch or other suitable tool (Fig. 7-12), loosen seal from extension and remove.

5. Wash counterbore with cleaning solvent and inspect for damage.

6. Inspect propeller shaft yoke hub for nicks, burrs or scratches which would cut new seal or cause seal to leak or damage bushing.

#### TRANSMISSION EXTENSION OIL SEAL - REPLACE

1. Coat new seal with sealing compound and start straight in bore of case extension. Using installer J-5154-A, tap seal into counterbore (Fig. 7-13).

2. Install propeller shaft assembly by reversing steps 1 through 3 under removal of oil seal.

#### TRANSMISSION SIDE COVER—REMOVE

It is not necessary to remove the transmission from the vehicle for inspection or replacement of parts in the transmission side cover assembly, but the side cover assembly itself must be removed from the transmission case.

1. Disconnect first and reverse shifter rod from shift lever at transmission by removing swivel nut assembly.

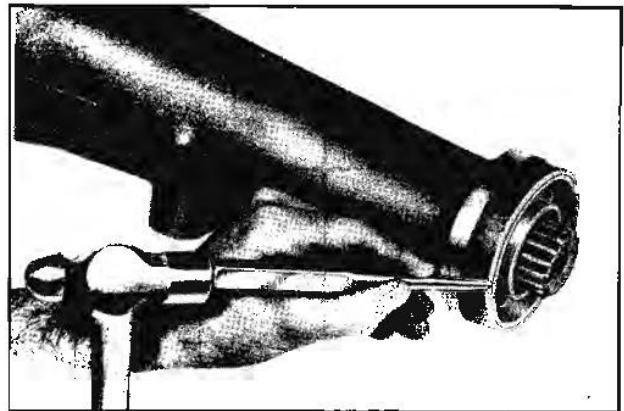

Fig. 7-12 Removing Extension Oil Seal

2. Disconnect lower end of second and third shifter rod by removing retainer.

3. Remove four transmission cover retaining bolts and lockwashers.

4. Remove side cover and gasket.

#### TRANSMISSION SIDE COVER—DISASSEMBLE

1. Remove nuts and locks from shifter interlock retainer and remove retainer (Fig. 7-14).

2. Remove detent cam spring to release detent cam (Fig. 7-14).

3. Remove both shifter shafts and shift fork assemblies.

4. Remove retaining ring and remove detent cam (Fig. 7-14).

5. Remove shifter interlock shaft.

6. Inspect and replace necessary parts.

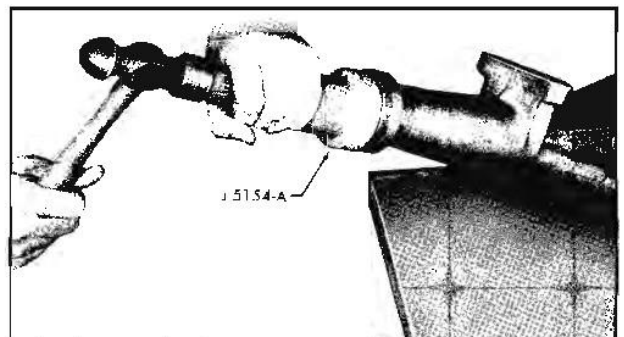

Fig. 7-13 Installing Extension Oil Seal

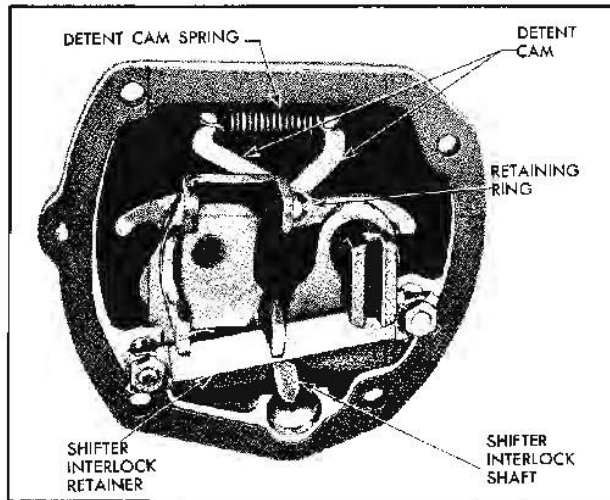

Fig. 7-14 Transmission Side Cover - Inner View

#### TRANSMISSION SIDE COVER— ASSEMBLE AND REPLACE

1. Install shifter interlock shaft.
  2. Install detent cam and retaining ring.
  3. Install shifter shafts and shift fork assemblies.
  4. Install detent cam spring.
  5. Install shifter interlock retainer and locks, and install interlock retainer nuts, tightening securely.
  6. Install outer shifter levers on shifter shaft and tighten bolts 10-20 lb. ft. torque.
  7. Install side cover gasket.
  8. Place transmission gears and shifter forks in neutral position and install cover.
- NOTE: Flanged side on first and reverse shifter fork must face rear of transmission as shown in Fig. 7-15.*
9. Apply special sealer compound to threads of four cover retaining bolts and install bolts and lock washers, tightening evenly to prevent cover distortion. Torque to 15 to 18 lb. ft.
  10. Install first and reverse shift lever (Fig. 7-8, 7-9, 7-10).

11. Install second and third shift lever and connect all rods.

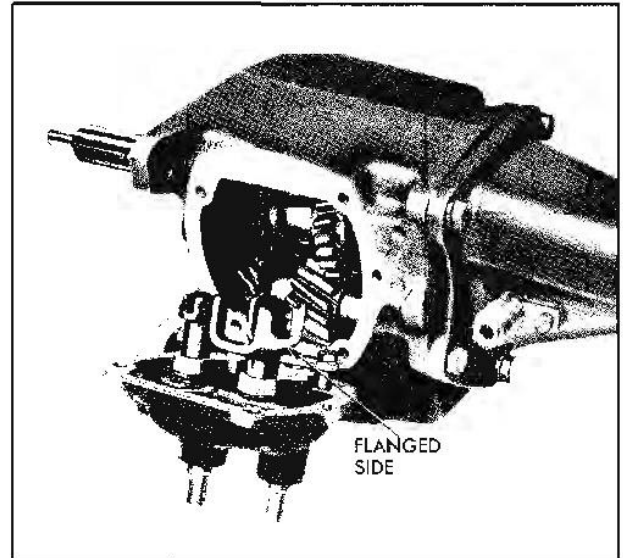

Fig. 7-15 Positioning First and Reverse Shifter Fork in Transmission Side Cover

12. Adjust linkage.

13. Remove filler plug at side of transmission and add SAE 90 "Multi-purpose Gear Lubricant". Lubricant level should be approximately level with bottom of filler plug hole.

#### MAJOR REPAIRS

##### TRANSMISSION—REMOVE AND OVERHAUL

1. Remove propeller shaft drive line assembly as follows:
  - a. Remove U-bolt nuts, lock plates and U-bolts from rear axle drive pinion flange.
  - b. Use a suitable rubber band to hold bearing onto journals, if tie wire has been removed, to prevent loss of needle bearings when rear joint is disconnected.
  - c. Remove complete drive line assembly by sliding rearward to disengage yoke from splines on transmission mainshaft.
1. Disconnect speedometer cable from speedometer driven gear.
3. Disconnect shift linkage from transmission.

*NOTE: If car is equipped with gear-shift control on the floor, also remove the lever and bracket assembly from side of the transmission extension.*

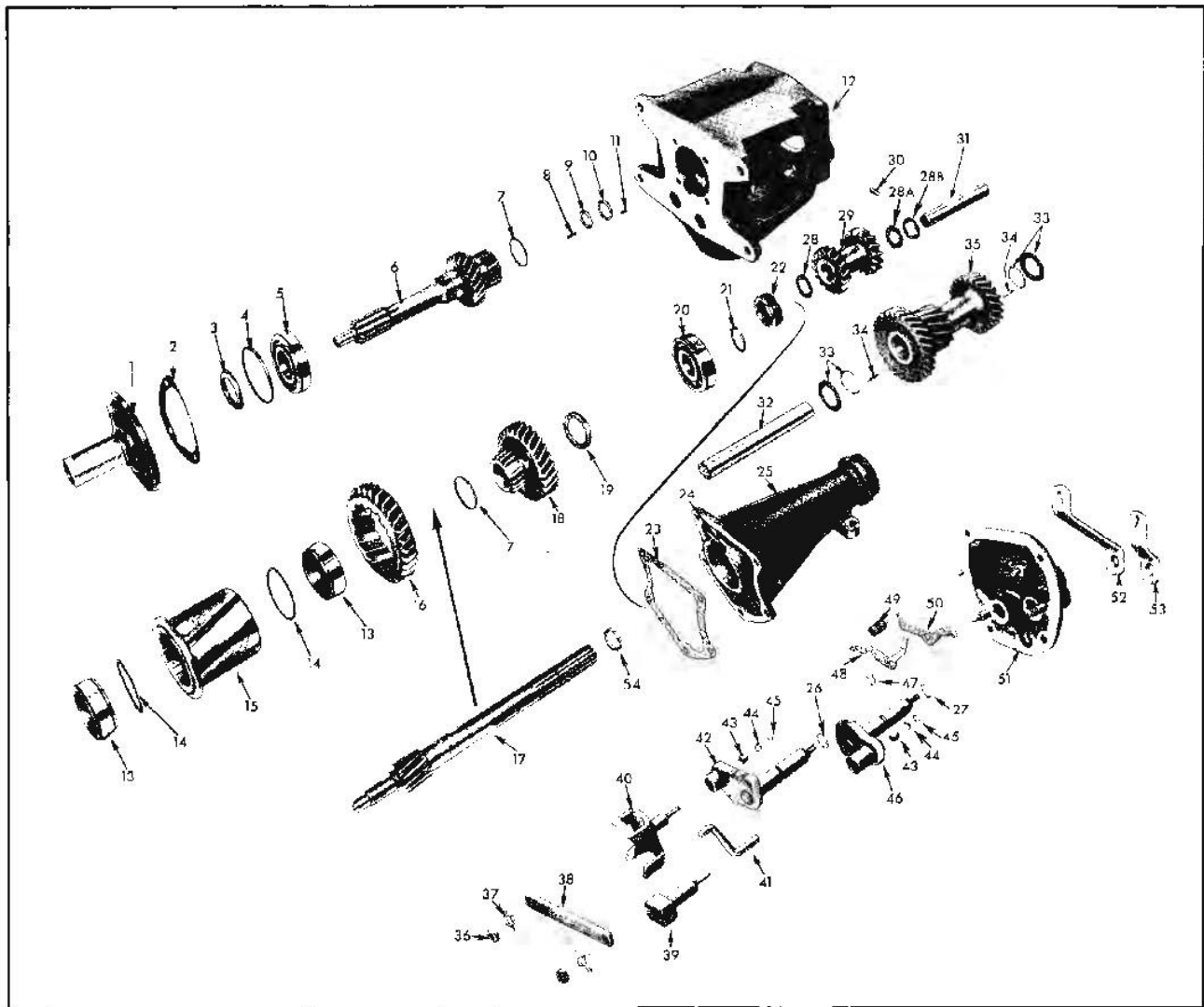

- |                                    |  |   |
|------------------------------------|--|---|
| 1. Clutch Gear Bearing Retainer    | 23. Case Extension Gasket                    | 38. Shifter Interlock Retainer                    |
| 2. Bearing Retainer Gasket         | 24. Rear Bearing Snap Ring                   | 39. Second and Third Shifter Fork                 |
| 3. Bearing Nut and Oil Slinger     | 25. Case Extension                           | 40. First and Reverse Shifter Fork                |
| 4. Bearing Snap Ring               | 26. First and Reverse Shifter Shaft "O" Ring | 41. Shifter Interlock Shaft                       |
| 5. Clutch Gear Bearing             | 27. Second and Third Shifter Shaft "O" Ring  | 42. First and Reverse Shifter Shaft & Plate Ass'y |
| 6. Clutch Gear                     | 28. Thrust Washer                            | 43. Shifter Fork Spacer                           |
| 7. Energizing Spring               | 28a. Thrust Bearing                          | 44. Shifter Fork Washer                           |
| 8. Front Pilot Bearing Roller      | 28b. Thrust Bearing Washer                   | 45. Shifter Fork Retainer                         |
| 9. Thrust Washer                   | 29. Reverse Idler Gear                       | 46. Second and Third Shifter Shaft & Plate Ass'y. |
| 10. Thrust Washer                  | 30. Reverse Idler Shaft Pin                  | 47. Detent Cam Retainer                           |
| 11. Rear Pilot Bearing Rollers     | 31. Reverse Idler Shaft                      | 48. First and Reverse Detent Cam                  |
| 12. Transmission Case              | 32. Countershaft                             | 49. Detent Cam Spring                             |
| 13. Synchronizer Ring              | 33. Countergear and Roller Thrust Washers    | 50. Second and Third Detent Cam                   |
| 14. Snap Ring                      | 34. Bearing Roller                           | 51. Side Cover                                    |
| 15. Second and Third Speed Clutch  | 35. Countergear                              | 52. First and Reverse Shifter Lever (Outer)       |
| 16. First and Reverse Sliding Gear | 36. Shifter Interlock Retainer Stud Nut      | 53. Second and Third Shifter Lever (Outer)        |
| 17. Mainshaft                      | 37. Shifter Interlock Retainer Stud Nut Lock | 54. Special Snap Ring                             |

Fig. 7-16 Three-Speed Synchronemesh Transmission - Exploded View

4. Support rear of engine with floor jack.
5. Remove two transmission insulator to cross member retaining bolts. (See Fig. 6-14, 6 cyl., Fig. 6-94, 8 cyl.).
6. Remove upper transmission to clutch housing bolts and insert transmission aligning studs J-1126.

*CAUTION: Aligning studs must be used since they support transmission and prevent distortion of clutch driven plate hub when lower transmission bolts are removed.*

7. Remove lower transmission to clutch housing bolts, tilt rear of extension upward to disengage bracket studs from cross member support and withdraw transmission from clutch housing.

8. When transmission is free of clutch housing, tilt front downward and remove.

#### TRANSMISSION - DISASSEMBLE

1. Remove four cover to transmission retaining bolts and remove cover and gasket.

*NOTE: If cover is to be disassembled for inspection and replacement of worn parts, follow procedures 1 through 6 under TRANSMISSION SIDE COVER - DISASSEMBLE.*

2. Remove insulator assembly from rear extension.
3. Remove extension to transmission case bolts and lockwashers.
4. Carefully pull extension and mainshaft assembly out of transmission case, leaving second and third speed clutch assembly and first and reverse sliding

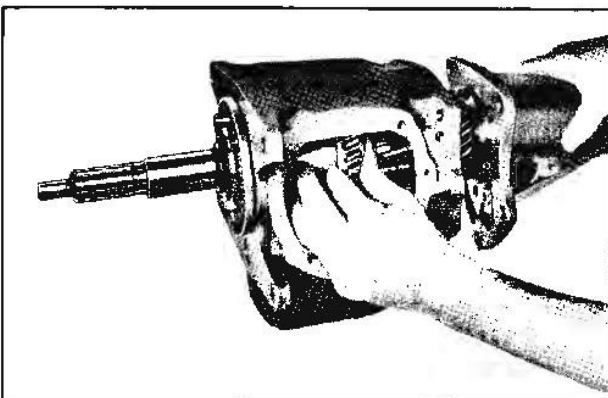

Fig. 7-17 Removal of Mainshaft

gear in case (Fig. 7-17). Do not force mainshaft. Slowly rotate mainshaft and second speed gear to obtain alignment of synchronizing clutch teeth and splines on mainshaft.

*NOTE: Care must be taken when pulling mainshaft from rear of case to prevent needle bearings in main drive (clutch) gear from dropping into case.*

5. Slide first and reverse gear from second and third speed clutch and remove through side opening in transmission case.

6. Remove second and third speed clutch from main drive (clutch) gear.

7. Remove 24 rear and 14 larger front pilot bearing rollers and thrust washers from inside the main drive (clutch) gear pilot hole (Fig. 7-16).

8. Remove the four main drive (clutch) gear bearing retainer bolts and lockwashers and remove retainer.

9. Remove bearing retainer gasket.

10. Remove countershaft by tapping it from front to rear of case with a brass drift approximately 1/4 inch. Complete removal of countershaft using loader J-5777 (Fig. 7-18). Lower the countergear, with loader J-5777 still in place, to bottom of case.

*NOTE: Countergear must be lowered before removing main drive (clutch) gear to prevent clutch gear bearing from striking countergear.*

11. Remove main drive (clutch) gear bearing snap ring (Fig. 7-18).

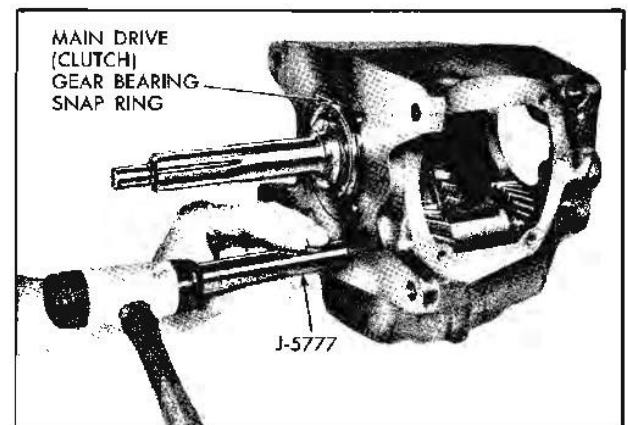

Fig. 7-18 Driving Countershaft Out of Transmission Case

12. Using soft hammer, tap front end of shaft, moving main (clutch) gear and bearing assembly into case. Remove through side opening (Fig. 7-19).

13. Remove countergear from rear of case and remove from countergear.

14. Remove thrust washers and 25 needle bearing rollers from each end of countergear.

15. Tap reverse idler shaft lock pin into shaft (Fig. 7-20). The pin is shorter than the diameter of the shaft so shaft may be removed when pin is driven in.

16. Using a drift pin, tap rear of reverse idler shaft, driving out case plug ahead of shaft.

*NOTE: Do not turn shaft while removing as lock pin may drop down between idler gear bushings.*

17. Remove reverse idler gear, front thrust washer, radial roller thrust bearing and rear thrust bearing washer.

18. To remove mainshaft from rear extension, remove speedometer driven gear assembly as described on page 7-9 under SPEEDOMETER DRIVEN GEAR - REMOVE, steps 1 through 5.

19. Remove rear extension to housing gasket.

20. Expand rear bearing snap ring, using tool J-932 (Fig. 7-21) and, while snap ring is expanded, tap rear of shaft with soft hammer to bring mainshaft assembly forward and out of extension.

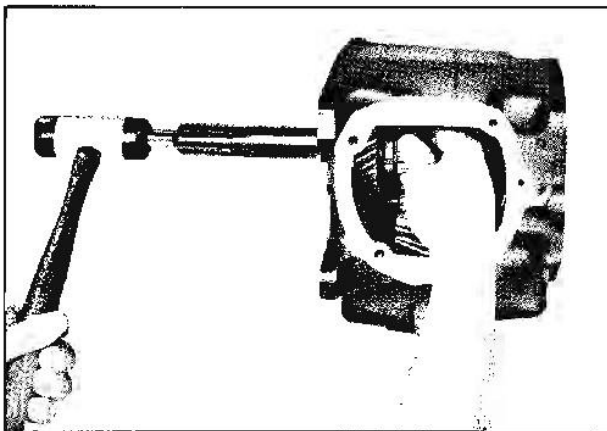

Fig. 7-19 Removing Clutch Gear and Bearing Assembly

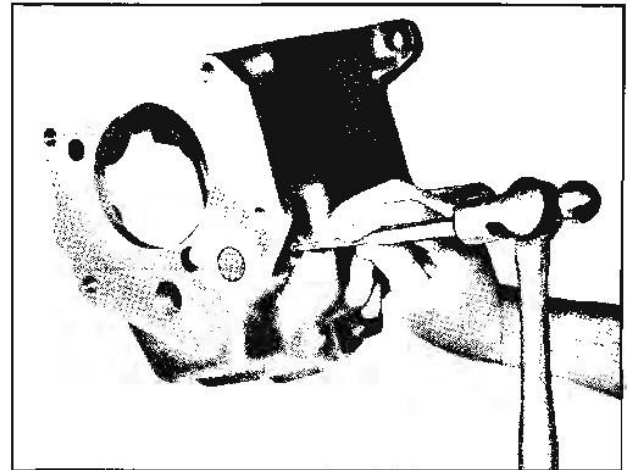

Fig. 7-20 Driving Reverse Idler Shaft Lock Pin into Shaft

#### MAINSHAFT ASSEMBLY - DISASSEMBLE

1. Remove special snap ring from end of mainshaft.

2. Press speedometer drive gear off mainshaft, using suitable split plates in an arbor press (Fig. 7-22).

3. Remove rear bearing to mainshaft snap ring and press bearing off shaft.

4. Remove second speed gear thrust washer and second speed gear.

#### MAIN DRIVE (CLUTCH) GEAR - DISASSEMBLE

1. Place main drive (clutch) gear in a vise with soft jaws and, using tool J-933, remove bearing retainer nut and oil slinger (Fig. 7-23).

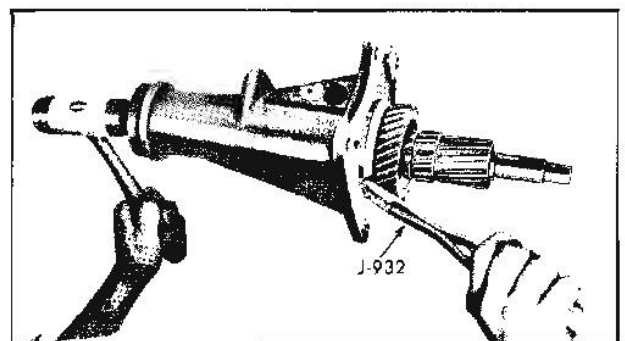

Fig. 7-21 Removing Mainshaft from Extension Housing

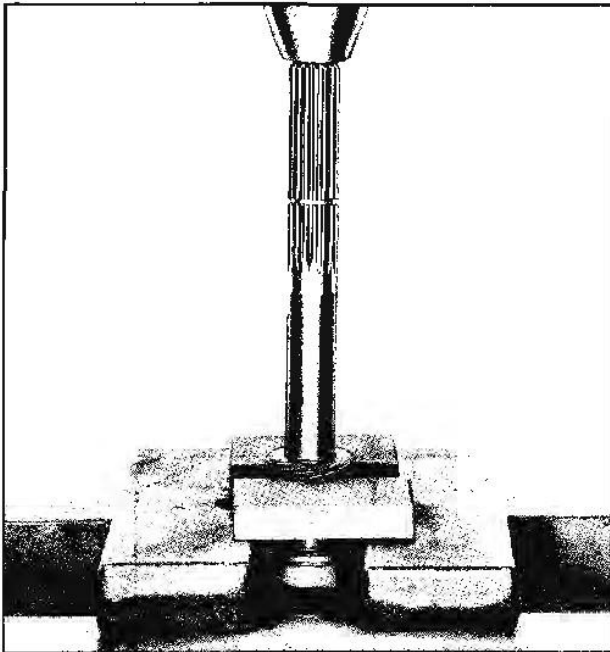

Fig. 7-22 Removing Speedometer Drive Gear

*NOTE: The retaining nut and oil slinger is a one-piece steel casting machined with a left-handed thread and locked in place on the main drive (clutch) gear shaft by being staked into a hole provided for that purpose.*

2. Install main drive (clutch) gear and bearing in transmission case and install snap ring on bearing.

3. Support rear of case in arbor press and press main drive (clutch) gear shaft from bearing (Fig. 7-24). Tap bearing from case.

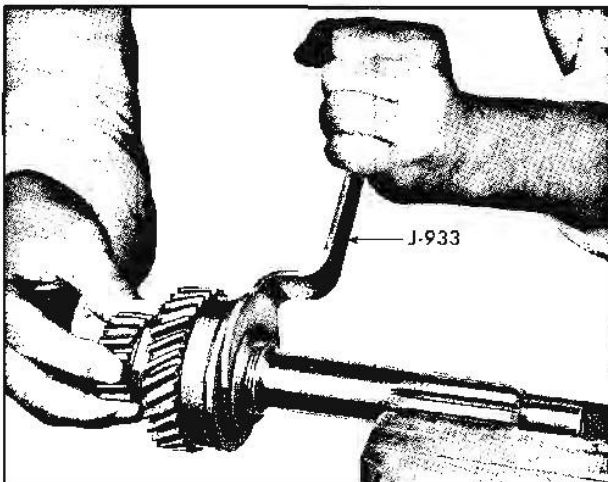

Fig. 7-23 Removing or Installing Oil Slinger

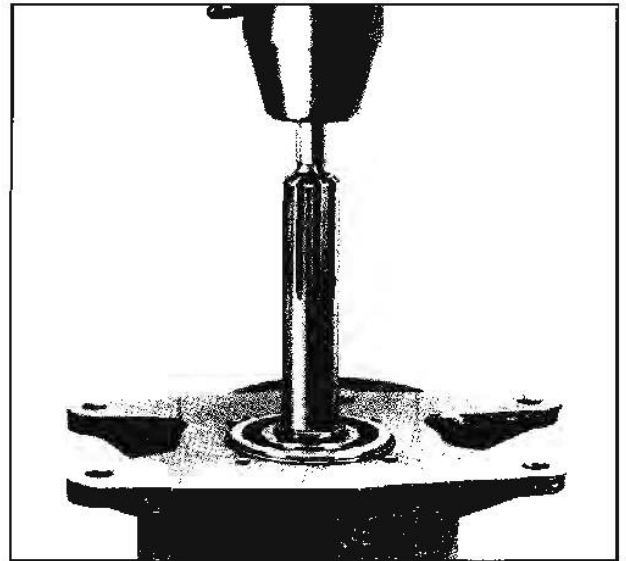

Fig. 7-24 Removing Clutch Gear Bearing

#### CLUTCH (SLEEVE) AND SYNCHRONIZER RINGS - DISASSEMBLE

1. Turn one synchronizer ring in the clutch (sleeve) until the ends of the ring retainer (snap ring) can be seen through the slot in clutch sleeve.

2. Using tool J-932, expand ring retainer in the counterbore in clutch sleeve (Fig. 7-25) and withdraw synchronizer ring.

3. Remove other synchronizer ring in same manner.

#### SYNCHRONIZER ENERGIZER SPRINGS - REMOVE

Under normal operation, it should never be necessary to replace the energizing springs, however, should an energizing spring be removed for any reason, a new spring should be installed. The synchronizer energizing spring may be removed by slipping a thin blade under the spring and raising it sufficiently to slide it over the clutch teeth.

#### TRANSMISSION CASE EXTENSION OIL SEAL AND BUSHING - REMOVE

1. Using punch or other suitable tool (Fig. 7-12), loosen oil seal from rear extension and remove.

*NOTE: Old oil seal should always be discarded after removal from extension.*



2. Using tool J-6399, drive bushing from rear into case extension (Fig. 7-26).

#### TRANSMISSION CASE AND EXTENSION

1. Wash transmission case and extension outside and inside with cleaning solvent and closely inspect for cracks.

2. Inspect faces for burrs or nicks and, if any are present, dress them off with a fine cut mill file.

3. Inspect transmission case extension bushing for excessive wear and replace if necessary.

#### BALL BEARINGS

1. Wash bearings thoroughly in cleaning solvent.
2. Blow out bearings with compressed air.

*CAUTION: Do not allow the bearings to spin, but turn them slowly by hand. Allowing bearings to spin will damage the race and balls.*

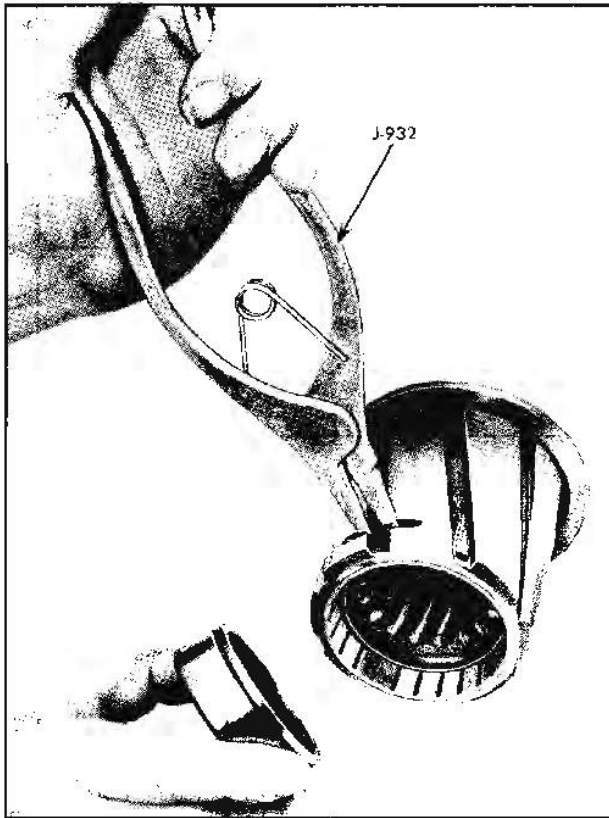

Fig. 7-25 Removing or Installing Synchronizer Ring

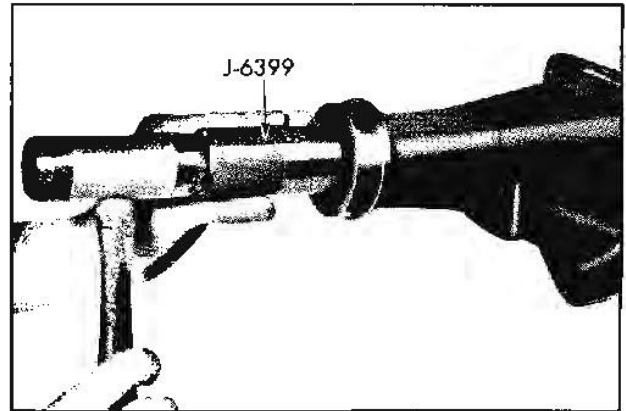

Fig. 7-26 Removing or Installing Bushing with J-6399

1. After cleaning bearings, lubricate them with light engine oil and check for roughness. Roughness may be determined by turning the outer race by hand.

#### GEARS

1. Inspect teeth of all gears for nicks or wear and, if necessary, replace any that are worn or damaged.
2. Check first and reverse sliding gear, making certain it slides freely on second and third speed clutch.
3. Check second and third speed clutch, making certain it slides freely on mainshaft.

#### REVERSE IDLER GEAR SHAFT, BUSHINGS, THRUST WASHERS AND BEARING; AND NEEDLE BEARING ROLLERS

1. Check reverse idler gear shaft for excessive wear and, if wear or damage is indicated, it should be replaced.
2. The bushings used in the reverse idler gear are pressed into the gear, then peened into holes in the bores to lock them in place. They are accurately bored with special diamond boring tools to insure positive alignment of the bushings and the shaft, as well as to insure proper meshing of the gears. Because of the high degree of accuracy to which these parts are machined, the bushings are never serviced separately.

3. Check bushings for excessive wear by inserting a narrow feeler gauge between the shaft and the bushing. The proper clearance is from .002" to .004".

4. The thrust washers and radial roller thrust bearing should be closely examined for wear or damage and replaced if wear or damage is indicated.

5. The 50 countergear needle bearing rollers should be closely inspected for excessive wear and replaced if worn.

6. Closely inspect the 14 front and 24 rear mainshaft pilot needle bearing rollers and replace if worn.

#### CLUTCH (SLEEVE) SYNCHRONIZER RINGS AND CONES

1. Check synchronizer cones for wear or for looseness in clutch sleeve. If cones are damaged in any way, it will be necessary to replace entire clutch assembly and both synchronizer rings.

2. Inspect synchronizer rings for smoothness.

3. Place synchronizer rings in synchronizer cones and apply pressure with thumbs to see that rings do not rock. Excessive rocking indicates a poor fit between rings and cones and prevents proper synchronizing of gears during shifting.

#### INTERNAL COMPONENTS—ASSEMBLE

##### TRANSMISSION CASE EXTENSION BUSHING AND OIL SEAL - REPLACE

1. Using tool J-6399, drive bushing, from rear of transmission, until end of bushing is slightly below counterbore for oil seal (Fig. 7-26). Coat I.D. of bushing with transmission oil.

2. To replace oil seal, coat new seal with sealing compound and start straight in bore of case extension. Using installer J-5154-A, tap seal into counterbore (Fig. 7-13).

##### SYNCHRONIZER ENERGIZING SPRINGS - REPLACE

1. One end of each spring is slightly offset. Each spring must be assembled in its groove in main drive (clutch) gear and second speed gear with offset, or locking end, between third and fourth tooth from either end of either of two banks of teeth on these gears. This prevents the spring from turning in its groove (Fig. 7-27).

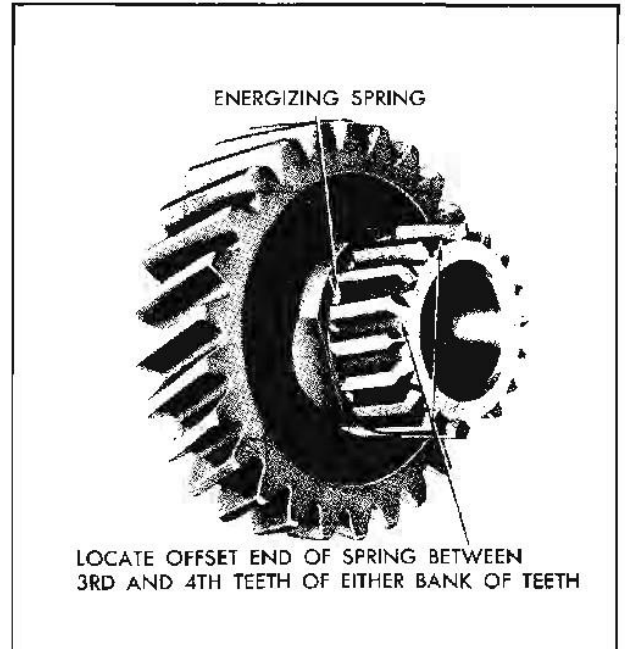

Fig. 7-27 Position of Synchronizer Ring Energizing Spring

*NOTE: In replacing energizing springs, be careful not to distort the springs by expanding them too much when sliding them over the clutch teeth of main drive (clutch) gear and second speed gear.*

##### CLUTCH (SLEEVE) AND SYNCHRONIZER RINGS - ASSEMBLE

1. Lubricate both synchronizer rings with light grease as an aid in preventing synchronizer ring "lock-up".

2. Install a synchronizer ring retainer (snap ring) in counterbore at one end of clutch sleeve.

3. Insert tool J-932 through slot in clutch sleeve (Fig. 7-25), and expand retainer in counterbore. Install synchronizer ring in clutch sleeve.

4. Install other synchronizer ring in same manner.

*NOTE: Make certain retainers seal fully in their grooves around the rings so rings will turn freely.*

##### MAIN DRIVE (CLUTCH) GEAR - ASSEMBLE

1. Using an arbor press, press main drive (clutch) gear bearing on main drive (clutch) gear shaft, making certain locating ring groove is toward the front of shaft.

2. Install combination clutch bearing retaining nut and oil slinger on main drive (clutch) gear shaft (Fig. 7-23), drawing it up tightly with tool J-933.

3. Lock retaining nut and oil slinger in place by staking it into flat on shaft with center punch. Use extreme care so as not to damage threads on shaft.

*CAUTION: The main drive (clutch) gear bearing must turn as freely after installation on shaft as it turned before being installed.*

#### MAINSHAFT ASSEMBLY - ASSEMBLE

1. Slide second speed gear on mainshaft, clutch hub to front.

2. Install thrust washer with oil grooves toward gear.

3. Press rear bearing on mainshaft, making certain groove in O.D. of bearing is toward second speed gear.

*NOTE: Check position of bearing snap ring groove before installing bearing on mainshaft. Bearing must seat forward of this groove with minimum amount of end play.*

4. Select one of four available snap rings so end play of bearing on shaft does not exceed .004". This may be easily determined by trying successively larger rings and selecting the thickest ring that will enter snap ring groove on shaft.

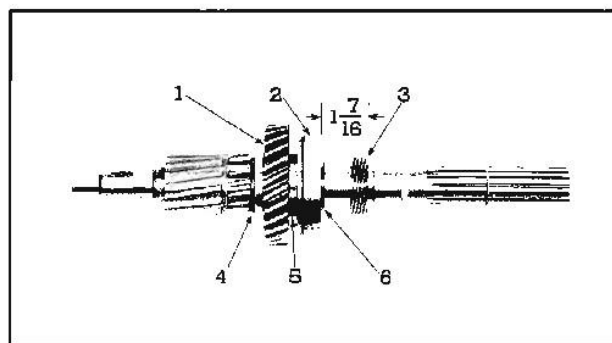

- |                           |                      |
|---------------------------|----------------------|
| 1. Second Speed Gear      | 4. Energizing Spring |
| 2. Rear Bearing           | 5. Thrust Washer     |
| 3. Speedometer Drive Gear | 6. Snap Ring         |

Fig. 7-28 Mainshaft Assembly

5. Start speedometer drive gear on shaft with chamfered I.D. of gear toward bearing. Press gear on shaft until rear face of gear is 1 7/16" from rear face of bearing (Fig. 7-28).

6. Install special snap ring on end of mainshaft.

#### TRANSMISSION—ASSEMBLE

##### REVERSE IDLER GEAR

1. Coat thrust washers and radial roller thrust bearing with grease.

2. Position radial roller thrust bearing against rear of gear (end with chamfered gear teeth) and position large thrust washer against bearing. Position small thrust washer at opposite (front end) of gear (Fig. 7-29).

3. From rear of case, install idler shaft, aligning lock pin hole in shaft with hole in case (Fig. 7-30), and tap shaft in until front of shaft is flush with inner side of rear boss.

4. Position reverse idler gear assembly in case so radial roller thrust bearing is toward rear of case and gear is lined up with shaft. With soft hammer, tap shaft from rear until lock pin holes are lined up.

5. Coat new idler shaft lock pin with sealer and drive it in approximately 1/16" beyond flush with case. Peen hole slightly to ensure lock pin is secure and to prevent oil leak.

6. Install new idler shaft expansion plug in front of case.

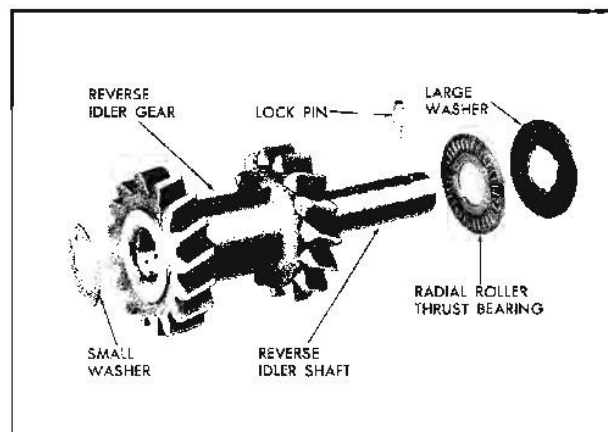

Fig. 7-29 Reverse Idler Gear, Shaft and Thrust Washers

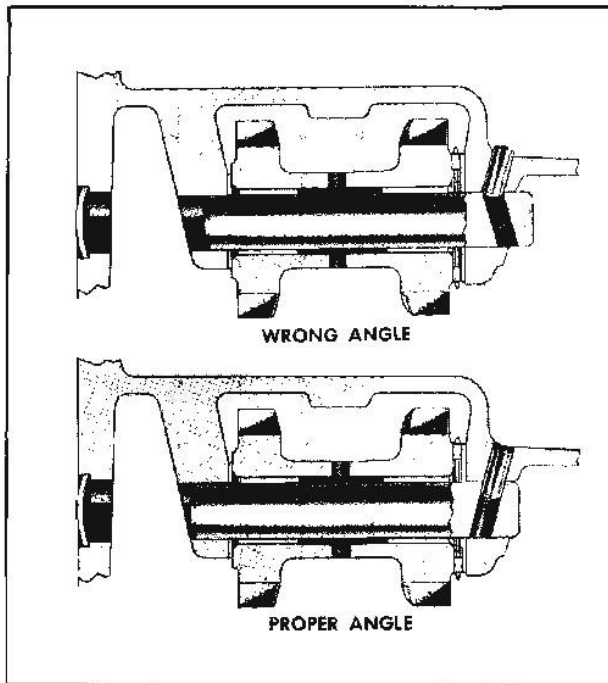

Fig. 7-30 Reverse Idler Gear Shaft and Lock Pin

#### COUNTERGEAR AND MAIN DRIVE (CLUTCH) GEAR

1. Apply cup grease in roller bearing area at each end of countergear and insert tool J-5777 in countergear.

2. Install 25 roller bearings, around tool J-5777, at each end of countergear. The grease will hold bearings in place while installing countergear assembly in case.

3. Apply grease to bearing thrust washers and countergear thrust washers and place bearing thrust washers, followed by countergear thrust washers, at both ends of countergear (Fig. 7-31), making certain tangs on countergear thrust washers face out.

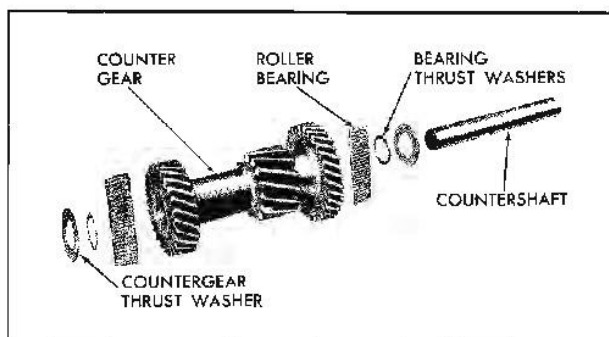

Fig. 7-31 Countergear Assembly

4. With tool J-5777 in position, place countergear in rear of transmission case, large gear first, and rest it on bottom of case.

5. From inside case, push main drive (clutch) gear assembly through opening in front face of case and, using a brass drift, tap the clutch gear assembly until the clutch gear bearing locating ring groove is outside front of case. Assembly must be driven straight to prevent damage to bearing (Fig. 7-32).

6. Install snap ring in bearing groove and tap main drive (clutch) gear toward the rear until snap ring rests firmly against face of case.

7. Install main drive (clutch) gear bearing retainer and new retainer gasket. Gasket must not protrude beyond edge of retainer.

*NOTE: The holes in the retainer are unevenly spaced so that retainer can be assembled to case in only one position, matching up oil return slot with oil outlet hole in case.*

8. Apply sealing compound to threads of four retainer to case bolts and install bolts and special lockwashers. Torque 12 to 15 lb. ft.

9. Turn transmission case on flat, or top side.

10. Lower countergear so that idler gear, main drive (clutch) gear and countergears mesh properly. Be careful that thrust washers at end of countergear are not dislodged.

11. Lubricate and start countershaft in case from rear, making certain that flat on end of shaft is horizontal and toward bottom of case.

*NOTE: Flat on shaft must be horizontal and at bottom to permit installation of case extension.*

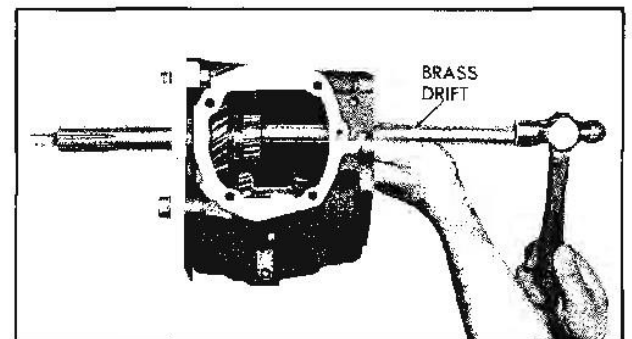

Fig. 7-32 Installation of Main Drive (Clutch) Gear Assembly

12. Align countergear with shaft and, using soft hammer, tap shaft through, pushing bearing loader J-5777 out front of case (Fig. 7-33).

13. Continue to tap shaft until flat on end is flush with rear face of case.

14. Apply cup grease to pilot hole in main drive (clutch) gear to retain pilot bearing rollers (Fig. 7-34).

15. Install the 14 larger rollers and then insert small I.D. spacer.

16. Insert the large I.D. front spacer, followed by the 24 smaller rollers.

#### SYNCHRONIZING CLUTCH SLEEVE - FIRST AND REVERSE SLIDING GEAR

1. Assemble first and reverse gear on the clutch assembly.

2. Insert both pieces into the side opening of the case by tipping the front end of the assembly into the opening first.

3. Align the lug of the synchronizing ring with the synchronizing slot of the clutch gear and position the assembly on gear to receive the mainshaft.

#### MAINSHAFT AND EXTENSION

1. Position snap ring in extension and carefully insert mainshaft assembly in transmission case extension. Using tool J-932, spread mainshaft bearing

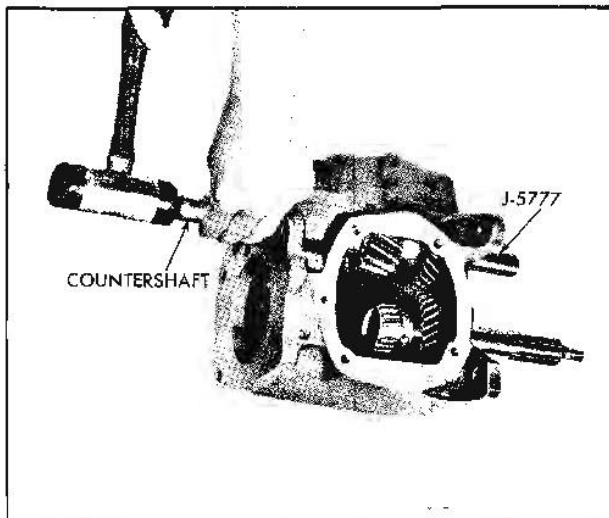

Fig. 7-33 Installation of Countershaft

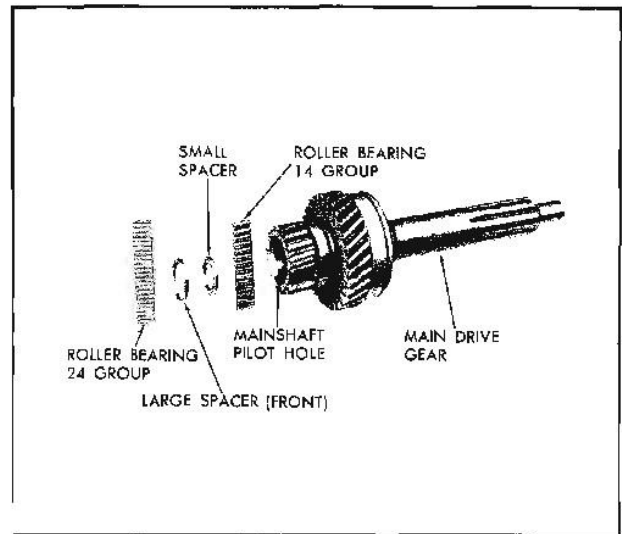

Fig. 7-34 Main Drive (Clutch) Gear Assembly

snap ring and tap front end of mainshaft, using soft hammer, until snap ring seats firmly in mainshaft bearing groove.

2. Affix new extension housing gasket to transmission case.

3. Align clutch splines on mainshaft with clutch splines on second speed gear so as to receive the two inner lugs of synchronizing ring of second and third speed clutch. Mark for identification (Fig. 7-35).

4. Lower mainshaft assembly through opening at rear of transmission case, making certain two inner

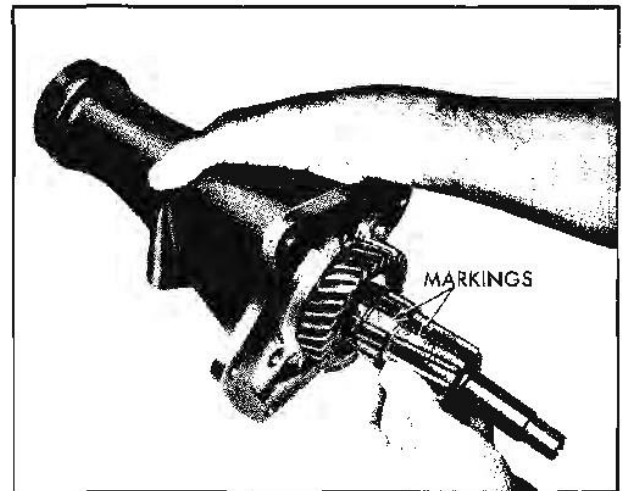

Fig. 7-35 Alignment of Synchronizer Clutch Splines on Mainshaft and Second Speed Gear

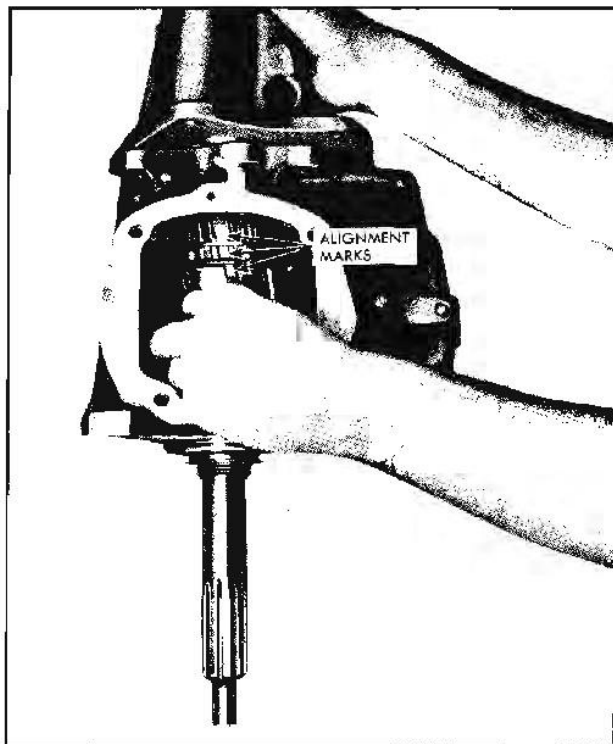

Fig. 7-36 Installing Mainshaft in Transmission Case

lugs of synchronizing ring engage previously marked grooves of mainshaft and second speed gear (Fig. 7-36).

*CAUTION: Use extreme care when lowering mainshaft assembly into transmission case to prevent roller bearings from falling into mainshaft pilot hole. Sudden weight exerted on synchronizing rings may cause them to lock up.*

5. Rotate extension housing to line up with case, insert the five extension housing to case bolts and washers, (apply special sealing compound to threads of bottom attaching bolt) and finger tighten.

6. Set transmission assembly, top side up, on bench. Maneuver second and third speed clutch until extension housing fits flush against transmission case. Tighten bolts 40 to 45 lb. ft. torque.

7. Install speedometer driven gear and fitting in extension housing as outlined under SPEEDOMETER DRIVEN GEAR - REPLACE, steps 1 through 5.

8. Install side cover as outlined under TRANSMISSION SIDE COVER - ASSEMBLE AND INSTALL.

9. Install clamp, bracket and insulator assembly on rear extension.

### TRANSMISSION—INSTALL IN VEHICLE

1. Raise transmission until rear extension can be moved rearwards over center cross member.

2. Move transmission forward, aligning with rear of clutch housing and lower rear extension until bracket studs engage holes in cross member support.

3. Insert aligning studs J-1126 in upper transmission to clutch housing bolt holes.

4. Install two lower transmission to clutch housing bolts and tighten 45-60 lb. ft. torque.

5. Remove aligning studs and install two upper transmission to clutch housing bolts and tighten 45-60 lb. ft. torque.

6. Install transmission extension to cross member insulator. Tighten bolts to 25-35 lb. ft. torque. (See Fig. 6-14, 6 cyl., Fig. 6-94, 8 cyl.)

7. Connect shift linkage. (See gearshift Linkage Adjustment pg. 7-6).

*NOTE: If car is equipped with gearshift control on the floor, also install lever and bracket assembly to side of transmission extension. Tighten bolts to 20-35 lb. ft. torque and nut 45-55 lb. ft. torque.*

8. Connect speedometer cable to speedometer driven gear fitting.

9. Install propeller shaft drive line assembly by reversing steps a. through c. under TRANSMISSION - REMOVE FROM VEHICLE.

10. Remove filler plug at side of transmission and add 1.8 pints of SAE 90 "Multi-purpose Gear Lubricant". Lubricant level should be approximately level with bottom of filler plug hole. Install plug.

11. Check complete shift pattern and adjust as required.

## TROUBLE DIAGNOSIS AND TESTING

TROUBLE	REMEDY
SLIPS OUT OF HIGH GEAR	
a. Transmission loose on clutch housing.	a. Tighten mounting bolts.
b. Shift rods interfere with engine mounts or clutch throw-out lever.	b. Replace or bend levers and rods to eliminate interference.
c. Shifter linkage does not work freely, binds.	c. Adjust and free up shift linkage. Torque reactions of engine should not cause the lever on transmission to move. The movement of transmission with respect to body and frame should be transferred to the control linkage.
d. Does not fully engage.	d. Measure length of engagement pattern on clutching teeth. If less than 7/64", check for bent levers, shifter shafts, detent cam plates, control rods and other shift linkage. Replace or straighten defective parts.
e. Damaged mainshaft pilot bearing.	e. Replace pilot bearing.
f. Main drive (clutch) gear bearing retainer broken or loose.	f. Tighten or replace main drive (clutch) gear bearing retainer.
g. Dirt between transmission case and clutch housing.	g. Clean mating surfaces.
h. Misalignment of transmission.	h. Shim between transmission case and clutch housing.
NOISY IN ALL GEARS	
a. Insufficient lubricant.	a. Fill to correct level.
b. Worn countergear bearings.	b. Replace countergear bearings and shaft.
c. Worn or damaged main drive (clutch) gear and countergear.	c. Replace worn or damaged gears.
d. Damaged main drive (clutch) gear or mainshaft ball bearings.	d. Replace damaged bearings.
e. Damaged speedometer gears.	e. Replace damaged gears.
NOISY IN HIGH GEAR	
a. Damaged main drive (clutch) gear bearing.	a. Replace damaged bearing.
b. Damaged mainshaft bearing.	b. Replace damaged bearing.
c. Damaged speedometer gears.	c. Replace speedometer gears.

NOISY IN NEUTRAL WITH  
ENGINE RUNNING

- |  |                             |
|--|-----------------------------|
| a. Damaged main drive (clutch) gear bearing. | a. Replace damaged bearing. |
| b. Damaged mainshaft bearing.                | b. Replace damaged bearing. |

NOISY IN ALL REDUCTION GEARS

- |  |                                     |
|--|-------------------------------------|
| a. Insufficient lubricant.                     | a. Fill to correct level.           |
| b. Worn or damaged clutch gear or countergear. | b. Replace faulty or damaged gears. |

NOISY IN SECOND ONLY

- |  |  |
|--|--|
| a. Damaged or worn second speed constant mesh gears. | a. Replace damaged gears.                  |
| b. Worn or damaged countergear rear bearings.        | b. Replace countergear bearings and shaft. |

NOISY IN LOW AND REVERSE ONLY

- |  |                                  |
|--|----------------------------------|
| a. Worn or damaged first and reverse sliding gear. | a. Replace worn gear.            |
| b. Damaged or worn low and reverse countergear.    | b. Replace countergear assembly. |

NOISY IN REVERSE ONLY

- |   |   |
|---|---|
| a. Worn or damaged reverse idler gear.  | a. Replace reverse idler gear assembly. |
| b. Worn reverse idler bushings.         | b. Replace reverse idler gear assembly. |
| c. Damaged or worn reverse countergear. | c. Replace countergear assembly.        |

EXCESSIVE BACKLASH IN SECOND ONLY

- |   |  |
|---|--|
| a. Second speed gear thrust washer worn.                  | a. Replace thrust washer.                      |
| b. Mainshaft rear bearing not properly installed in case. | b. Replace bearing, lock or case as necessary. |
| c. Universal joint retaining bolt loose.                  | c. Tighten bolt.                               |
| d. Worn countergear rear bearing.                         | d. Replace countergear bearings and shaft.     |

EXCESSIVE BACKLASH IN ALL  
REDUCTION GEARS

- |                                       |  |
|---------------------------------------|--|
| a. Worn countergear bushings.         | a. Replace countergear.                |
| b. Excessive end play in countergear. | b. Replace countergear thrust washers. |



LEAKS LUBRICANT

- |   |                                     |
|---|-------------------------------------|
| a. Excessive amount of lubricant in transmission.             | a. Drain to correct level.          |
| b. Loose or broken main drive (clutch) gear bearing retainer. | b. Tighten or replace retainer.     |
| c. Main drive (clutch) gear bearing retainer gasket damaged.  | c. Replace gasket.                  |
| d. Cover loose or gasket damaged.                             | d. Tighten cover or replace gasket. |
| e. Operating shaft seal leaks.                                | e. Replace operating shaft seal.    |
| f. Idler shaft expansion plugs loose.                         | f. Replace expansion plugs.         |
| g. Countershaft loose in case.                                | g. Replace case.                    |

TRANSMISSION SPECIFICATIONS

The transmission face, clutch housing and block are accurately squared in production so that each unit may be interchanged as necessary. Special alignment of these assemblies is not necessary if they are installed properly.

Shift Positions	Gear Ratios	
	6 Cyl.	8 Cyl.
Low . . . . .	2.94	2.58
Second . . . . .	1.68	1.48
Third . . . . .	1.1	1.1
Reverse . . . . .	2.94	2.58
Lubricant Capacity . . . . .	1.8 Pints	

TORQUE SPECIFICATIONS

	Lb. Ft.		Lb. Ft.
Transmission Drain Plug . . . . .	25-35	Transmission Control Lever and Bracket Assembly to Transmission	
Transmission Filler Plug . . . . .	25-35	Extension Bolt . . . . .	20-35
Rear Extension Bolts . . . . .	40-45	Transmission Control Lever and Bracket Support to Transmission	
Side Cover Bolts . . . . .	15-18	Extension Bolt . . . . .	20-35
Clutch Gear Bearing Retainer Bolts . . . . .	12-15	Transmission Support Mount Assembly to Crossmember . . . . .	25-35
Transmission to Flywheel Housing . . . . .	45-60		Lb. In.
Transmission Shifter Lever to Shaft Nuts . . . . .	10-20	Speedometer Driven Gear Retainer to Transmission Screw and Lockwasher . . . . .	35-60
Transmission Control Lever to 1st and Reverse Shift Rod Nut . . . . .	8-12	Speedometer Cable to Driven Gear Nut . . . . .	40-50
Transmission Control Lever to 2nd and 3rd Shift Rod Nut . . . . .	8-12		
Transmission Control Lever and Bracket Assembly to Support Nut . . . . .	45-55		

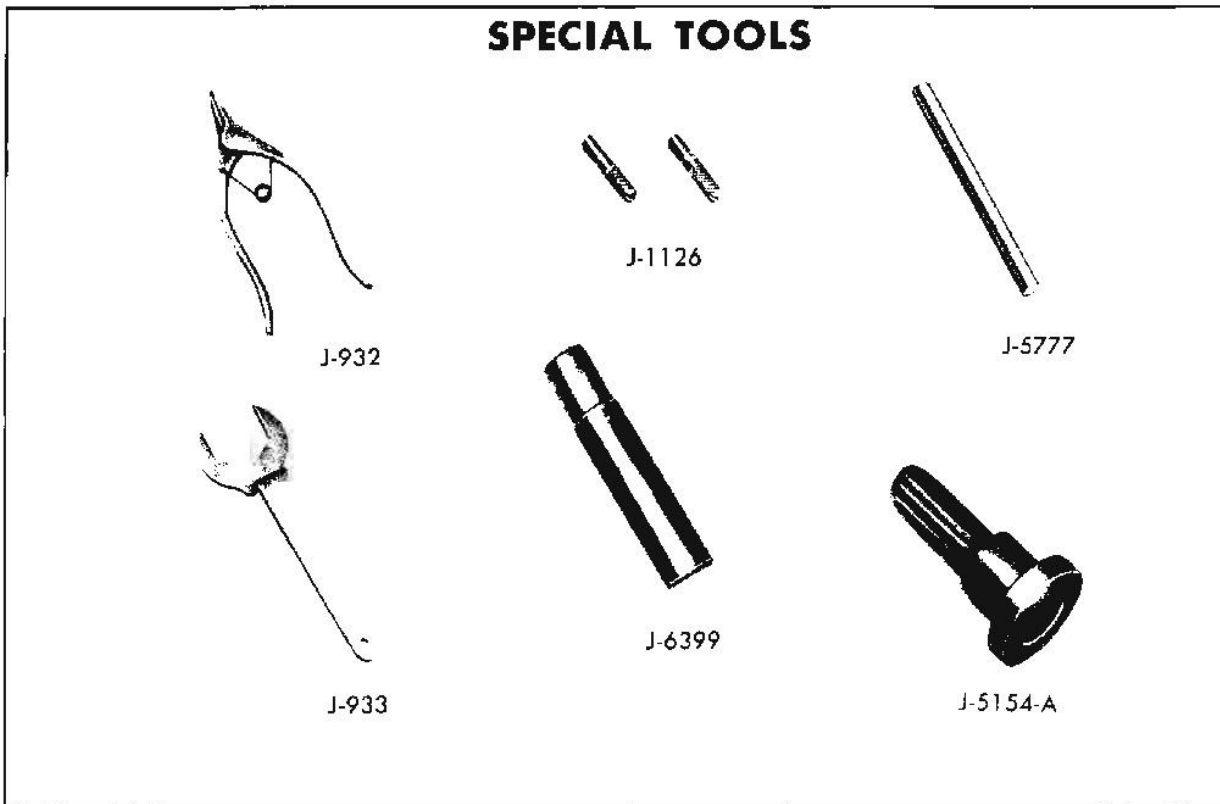

- |          |   |
|----------|---|
| J-932    | Snap Ring Pliers                                    |
| J-933    | Clutch Gear Retainer Nut Wrench                     |
| J-1126   | Aligning Studs                                      |
| J-5154-A | Transmission Extension Oil Seal Installer           |
| J-5777   | Countershaft Bearing Loader                         |
| J-6399   | Rear Bearing Extension Bushing - Remove and Replace |

Fig. 7-37 Synchromesh Transmission Special Tools